



**Victorian Certificate of Education
2005**

SUPERVISOR TO ATTACH PROCESSING LABEL HERE

STUDENT NUMBER

Letter

Figures
Words

--

PHYSICS
Written examination 1
Monday 6 June 2005

Reading time: 11.45 am to 12.00 noon (15 minutes)
Writing time: 12.00 noon to 1.30 pm (1 hour 30 minutes)

QUESTION AND ANSWER BOOK

Structure of book

<i>Section</i>	<i>Number of questions</i>	<i>Number of questions to be answered</i>	<i>Number of marks</i>
A – Core – Areas of study			
1. Motion in one and two dimensions	16	16	40
2. Electronics and photonics	10	10	25
B – Detailed studies			
1. Einstein’s special relativity (page 14)	10	10	25
OR			
2. Investigating materials and their use in structures (page 19)	12	12	25
OR			
3. Further electronics (page 25)	11	11	25
			Total 90

- Students are permitted to bring into the examination room: pens, pencils, highlighters, erasers, sharpeners, rulers, up to two pages (one A4 sheet) of pre-written notes (typed or handwritten) and an approved graphics calculator (memory cleared) and/or one scientific calculator.
- Students are NOT permitted to bring into the examination room: blank sheets of paper and/or white out liquid/tape.

Materials supplied

- Question and answer book of 29 pages with a detachable data sheet in the centrefold.

Instructions

- Detach the data sheet from the centre of this book during reading time.
- Write your **student number** in the space provided above on this page.
- Answer all questions in the spaces provided.
- **Always** show your working where space is provided.
- Where an answer box has a unit printed in it, give your answer in that unit.
- You should take the value of g to be 10 m s^{-2} .
- All written responses must be in English.

Students are NOT permitted to bring mobile phones and/or any other electronic communication devices into the examination room.

SECTION A – Core

Instructions for Section A
 Answer **all** questions **for both** Areas of study in this section of the paper.

Area of Study 1 – Motion in one and two dimensions

A model rocket of mass 0.20 kg is launched by means of a spring, as shown in Figure 1. The spring is initially compressed by 20 cm, and the rocket leaves the spring as it reaches its natural length. The force-compression characteristic of the spring is shown in Figure 2.

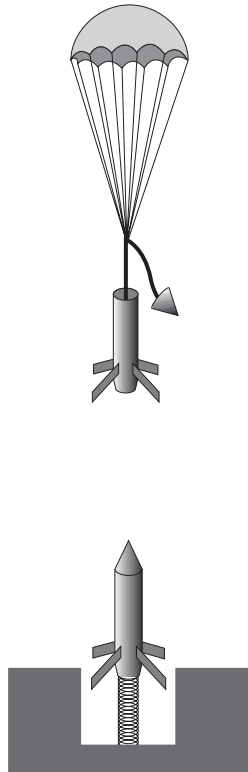

Figure 1

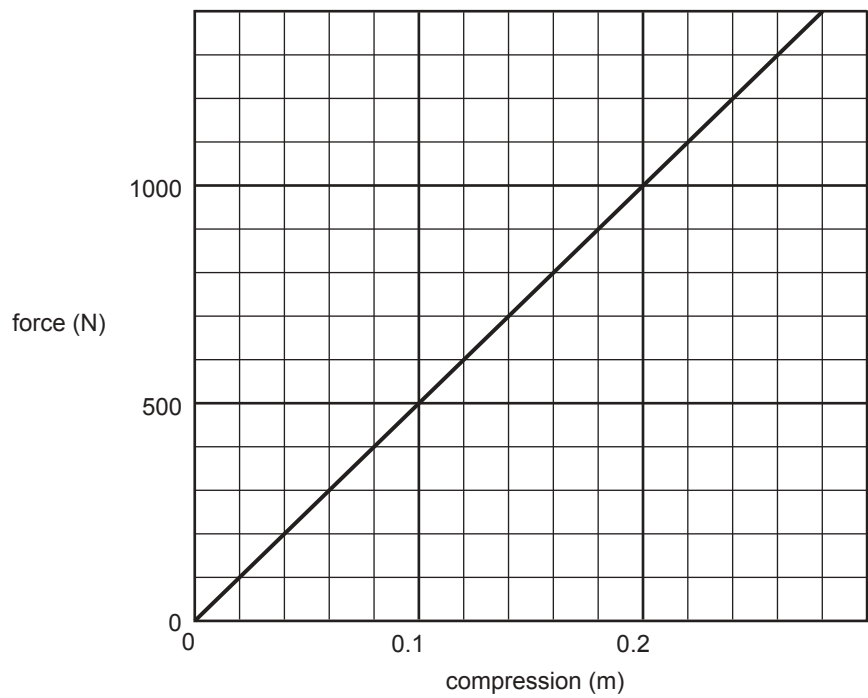

Figure 2

Question 1

How much energy is stored in the spring when it is compressed?

J

2 marks

Question 2

What is the speed of the rocket as it leaves the spring?

m s⁻¹

2 marks

Question 3

What is the maximum height, above the spring, reached by the rocket? You should ignore air resistance on the way up since the rocket is very narrow.

m

2 marks

When the rocket reaches its maximum height, the parachute opens and the system begins to fall. In the following questions you should still ignore the effects of air resistance on the rocket, but of course it is critical to the force on the parachute. This retarding force due to the parachute is shown as **R** in Figure 3, and its variation as a function of time after the parachute opened is shown in Figure 4.

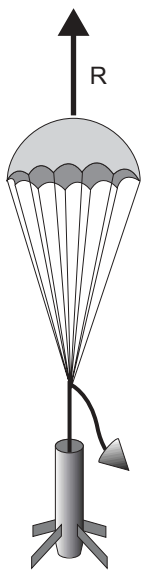
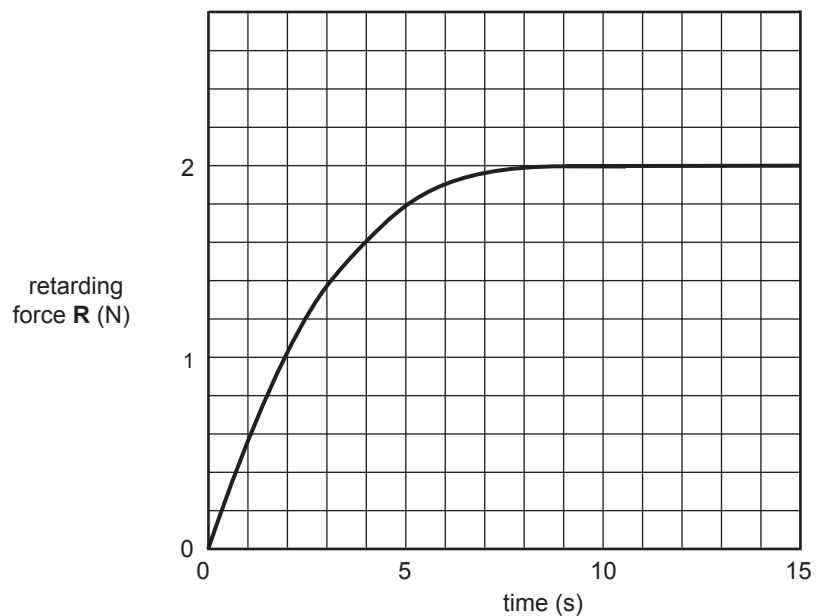
**Figure 3****Figure 4****Question 4**

What is the acceleration of the rocket at a time 5 s after the parachute opens?

m s^{-2}

3 marks

The safe speed for a train taking a curve on level ground is determined by the force that the rails can take before they move sideways relative to the ground. From time to time trains derail because they take curves at speeds greater than that recommended for safe travel.

Figure 5 shows a train at position P taking a curve on horizontal ground, at a constant speed, in the direction shown by the arrow.

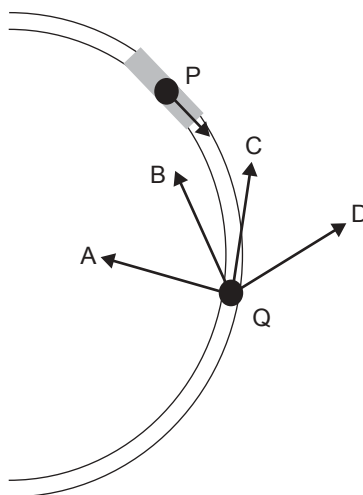

Figure 5

Question 5

At point P shown on the figure, draw an arrow that shows the direction of the force exerted by the rails **on the wheels** of the train.

2 marks

The radius of curvature of a track that is safe at 60 km/h is approximately 200 m.

Question 6

What is the radius of curvature of a track that would be safe at a speed of 120 km/h, assuming that the track is constructed to the same strength as for a 60 km/h curve?

m

3 marks

Question 7

At point Q the driver applies the brakes to slow down the train on the curve.

Which of the arrows (A–D) indicates the direction of the **net** force exerted **on the wheels** by the rails?

2 marks

A small truck of mass 3.0 tonne collides with a stationary car of mass 1.0 tonne. They remain locked together as they move off. The speed immediately after the collision was known to be 7.0 m s^{-1} from the jammed reading on the car speedometer. Robin, one of the police investigating the crash, uses ‘conservation of momentum’ to estimate the speed of the truck before the collision.

Question 8

What value did Robin obtain?

m s^{-1}

3 marks

The calculated value is questioned by the other investigator, Chris, who believes that ‘conservation of momentum’ only applies in elastic collisions.

Question 9

Explain why Chris’s comment is wrong.

2 marks

Question 10

Use a calculation to show whether the collision was elastic or inelastic. Write your conclusion in the box.

--

3 marks



Fred is playing tennis on the deck of a moving ship. He serves the ball so that it leaves the racket 3.0 m above the deck and travels perpendicular to the direction of motion of the ship. The ball leaves the racket at an angle of 8° to the horizontal. **At its maximum height** it has a speed of 30.0 m s^{-1} . You may ignore air resistance in the following questions.

Question 11

With what speed, relative to the deck, did the ball leave Fred's racket? Give your answer to three significant figures.

m s^{-1}

3 marks

Question 12

At its highest point, how far was the ball **above the deck**?

m

3 marks

The ship is travelling straight ahead at a velocity of 10 m s^{-1} .

Question 13

When the ball is at its highest point

a. at what **speed** is it moving **relative to the ocean**?

speed	m s^{-1}
-------	-------------------

b. at what **angle** is the ball travelling **relative to the direction** of the ship's travel?

angle	$^{\circ}$
-------	------------

3 marks

Newton was the first person to quantify the gravitational force between two masses M and m , with their centres-of-mass separated by a distance R as

$$F = G \frac{Mm}{R^2} \text{ where } G \text{ is the universal gravitational constant, and has a value of } 6.67 \times 10^{-11} \text{ N m}^2 \text{ kg}^{-2}.$$

For a mass m **on the surface of Earth** (mass M) this becomes $F = gm$, where $g = G \frac{M}{R^2}$

Question 14

Which one of the expressions (A–D) **does not** describe the term g ?

- A. g is the gravitational field at the surface of Earth.
- B. g is the force that a mass m feels at the surface of Earth.
- C. g is the force experienced by a mass of 1 kg at the surface of Earth.
- D. g is the acceleration of a free body at the surface of Earth.

2 marks

Question 15

What is the magnitude of the force exerted by Earth on a water molecule of mass 3.0×10^{-26} kg at the surface of Earth?

2 marks

A satellite in a circular orbit of radius 3.8×10^8 m around Earth has a period of 2.36×10^6 s.

Question 16

Calculate the mass of Earth. You **must** show your working.

3 marks

Area of Study 2 – Electronics and photonics

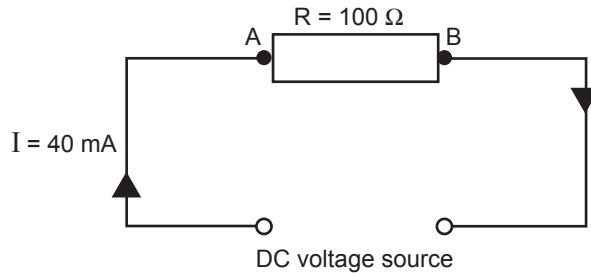

Figure 1

Figure 1 shows a resistor, a linear circuit component, with resistance $R = 100 \Omega$. A DC current, $I = 40 \text{ mA}$, passes through this resistor in the direction shown by the arrows.

Question 1

What is the voltage drop across this resistor? Express your answer in volts.

 V

2 marks

Question 2

Which one of the following statements (A–D) concerning the voltage across the resistor in Figure 1 is true?

- A. The potential at point A is higher than at point B.
- B. The potential at point A is the same as at point B.
- C. The potential at point A is lower than at point B.
- D. The potential at point A varies in sign with time compared to that at point B.

2 marks

Question 3

Determine the electrical energy dissipated in the 100Ω resistor of Figure 1 in 1 second. In your answer provide the unit.

2 marks

In Figure 2, five identical $100\ \Omega$ resistors are used to construct a voltage divider. The voltage source across this voltage divider is an AC supply with an RMS voltage of $20\ \text{V}$. The resistors are labelled by the letters **A–E** as shown.

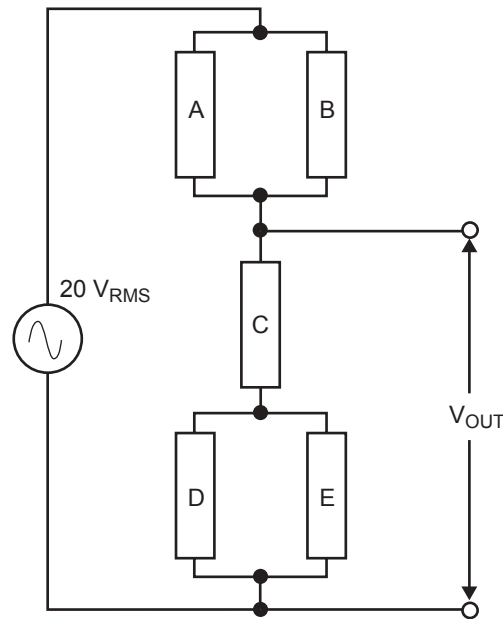

Figure 2

Question 4

What is the RMS output voltage, V_{OUT} ?

V_{RMS}

3 marks

Question 5

Which one of the following statements (**A–D**) concerning the RMS currents in the circuit of Figure 2 is true?

- A.** The current in resistor A is identical to the current in resistor C.
- B.** The current in resistor D is twice the current in resistor C.
- C.** The current in resistor B is twice the current in resistor E.
- D.** The current in resistor A is identical to the current in resistor D.

2 marks

Figure 3 shows a typical n-p-n transistor voltage amplifier circuit. You may assume that the transistor is correctly biased and the circuit is operating in the linear-amplification region. The DC collector current is 20 mA.

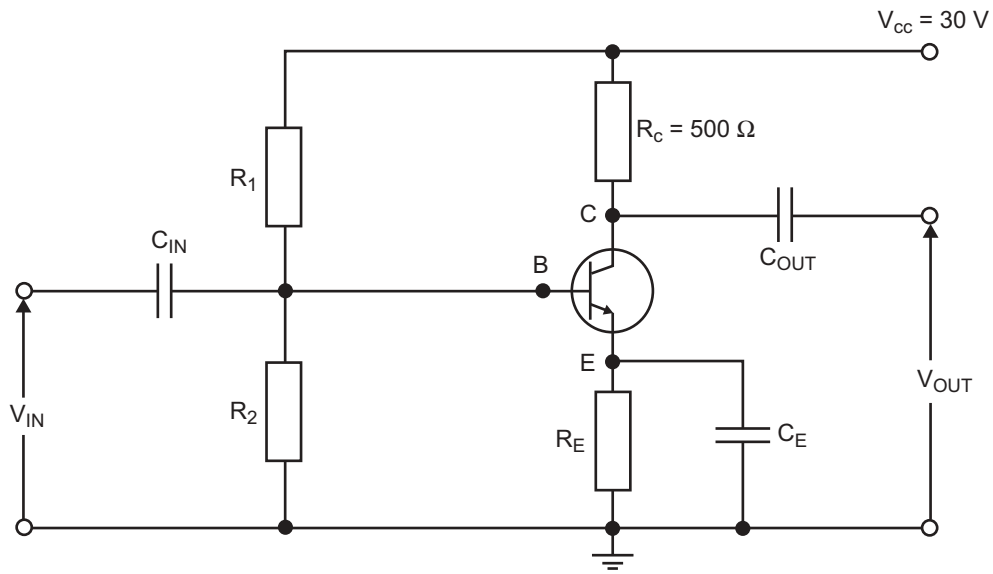

Figure 3

Question 6

Show that the voltage between point C and Earth is 20 V.

3 marks

The AC current gain of the transistor is 200.

A small time-varying AC voltage, V_{IN} , is applied at the input. As V_{IN} rises from 0 to 10 mV this causes the base current to increase from 0 to $5 \mu\text{A}$.

Question 7

Calculate the change in collector voltage, and determine the small-signal voltage gain of the amplifier circuit. Show your working.

voltage gain =

3 marks

Question 8

Describe the basic purpose of each of the following electronic transducers.

- i. Light-Emitting Diode (LED)

- ii. Photodiode

2 marks

The information on an audio CD is represented by a series of pits (small depressions) in the surface that are scanned by laser light. When there is no pit the reflected light gives a maximum light intensity, I_1 , detected by a photodiode circuit. When the laser light strikes a pit, the light intensity is reduced to I_0 . A plot of a typical light intensity incident on the photodiode is shown in Figure 4.

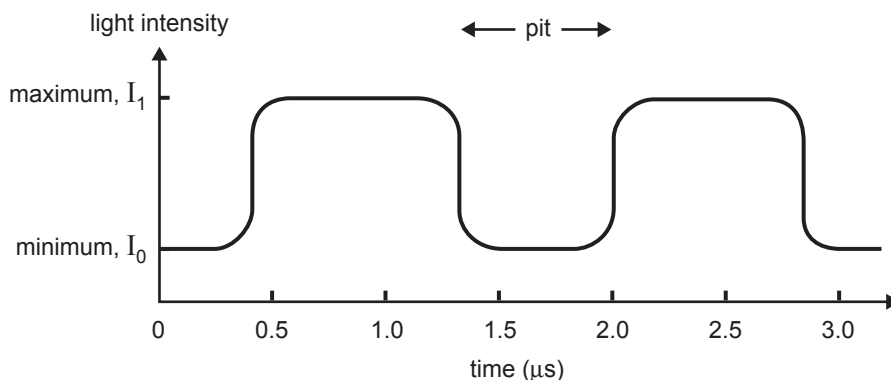

Figure 4

The variation in current as a function of light intensity for the photodiode is shown in Figure 5a, together with the circuit used to determine this, which is shown in Figure 5b.

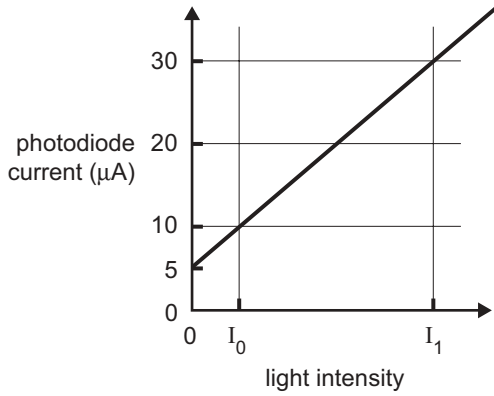

Figure 5a

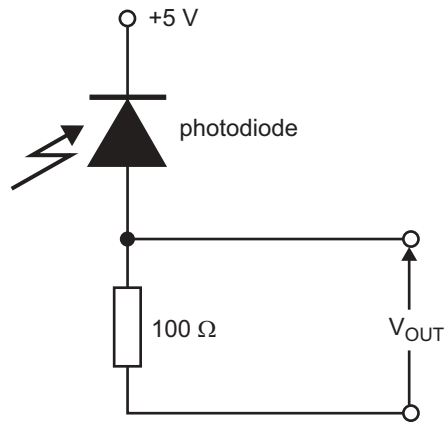

Figure 5b

Question 9

With no light incident upon the photodiode, the current in the photodiode circuit, the ‘dark current’, is 5 µA. What is the output voltage, V_{OUT} , across the 100 Ω resistor in the circuit of Figure 5b?

V

2 marks

A resistor is a linear device. An example of a non-linear device is a light-emitting diode (LED).

Question 10

On the axes provided, sketch a typical current-voltage characteristic curve for each of the devices mentioned. In both cases label the axes and indicate appropriate units.

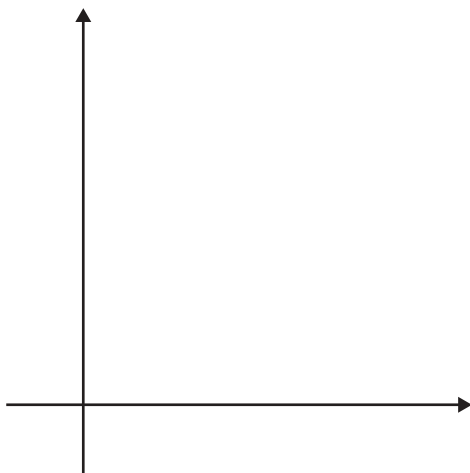

A linear device – a resistor

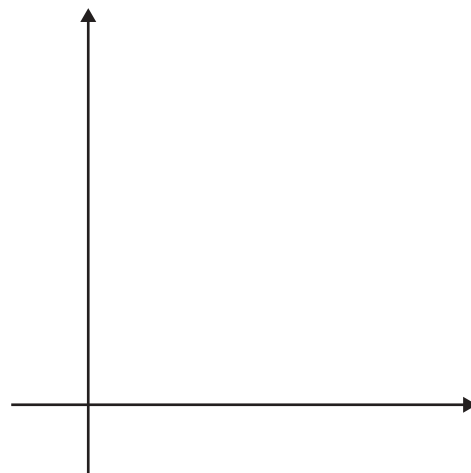

A non-linear device – an LED

4 marks

SECTION B – Detailed studies

Instructions for Section B

Choose **one** of the following **Detailed studies**. Answer **all** the questions on the Detailed study you have chosen.

Detailed study 1 – Einstein’s special relativity

According to the postulates of special relativity, certain properties are dependent on the reference frame in which they are observed.

Question 1

In column 2 of the table below, indicate whether the entry in column 1 is always the same (S), or may sometimes be different (D).

column 1	column 2
The mass of an electron measured at rest	
The time interval between two given events	
The distance between two given events	

3 marks

A Year 12 physics class is studying ‘Einstein’s special relativity’. The teacher postulates a thought experiment: ‘Imagine you are travelling at a speed of $3 \times 10^8 \text{ m s}^{-1}$ alongside a beam of light. What would you measure the speed of a beam of light to be?’.

Two students put up their hands to offer an answer.

Hilary says: You would measure the beam of light to be moving away from you at $3 \times 10^8 \text{ m s}^{-1}$.

Ryan says: You would measure the beam of light to be at rest with respect to yourself: that is, its speed would be 0 m s^{-1} .

Question 2

Which student’s answer is consistent with Einstein’s special theory of relativity? In the space below, write your choice and explain your reasoning.

3 marks

A container inside a rocket ship is observed through a window by Sam, an astronaut, **floating freely in space**. Sam observes the rocket ship travelling past at a constant speed $V_R = 0.2c$. The dimensions of the container, **as measured by astronauts inside the rocket ship**, are shown in Figure 1, and are

- the proper length L_0 (parallel to the direction of motion of the rocket ship)
- the proper width W_0 (perpendicular to the direction of motion of the rocket ship)
- the proper height H_0 (perpendicular to the direction of motion of the rocket ship).

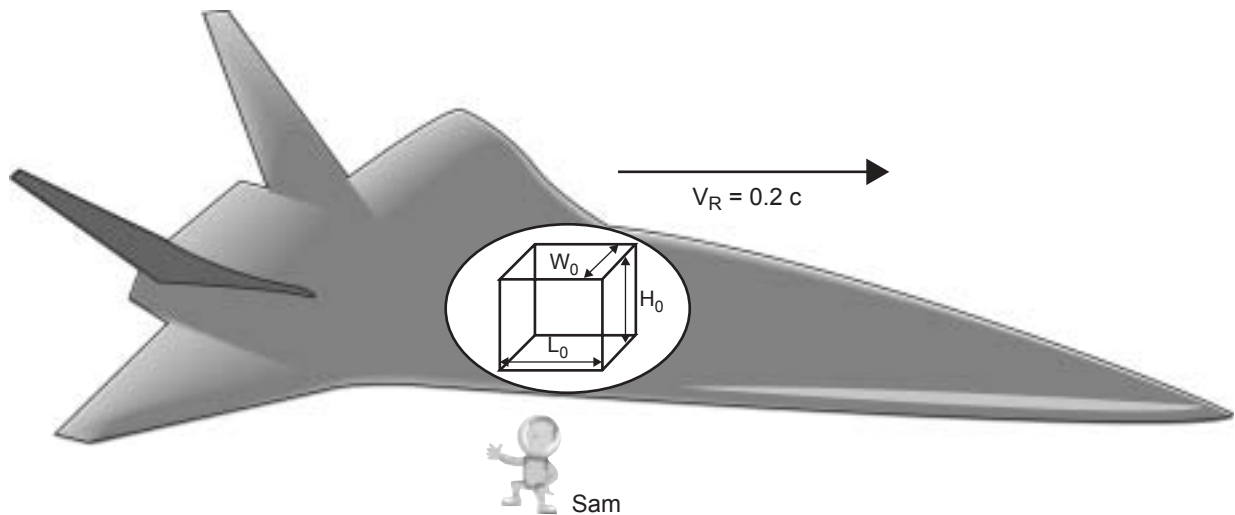

Figure 1

Question 3

Which of the options (A–D) best describes its dimensions **as observed by Sam**?

- A. $L < L_0, W < W_0, H < H_0$
- B. $L < L_0, W = W_0, H = H_0$
- C. $L > L_0, W = W_0, H = H_0$
- D. $L < L_0, W < W_0, H = H_0$

2 marks

Michelson and Morely hypothesised: if Earth moves around the Sun then it must travel though the ether. Since the medium through which light travels is the ether, there should be a difference in the measured speed of light depending on whether the light is travelling parallel to or perpendicular to the direction of Earth’s movement through the ether.

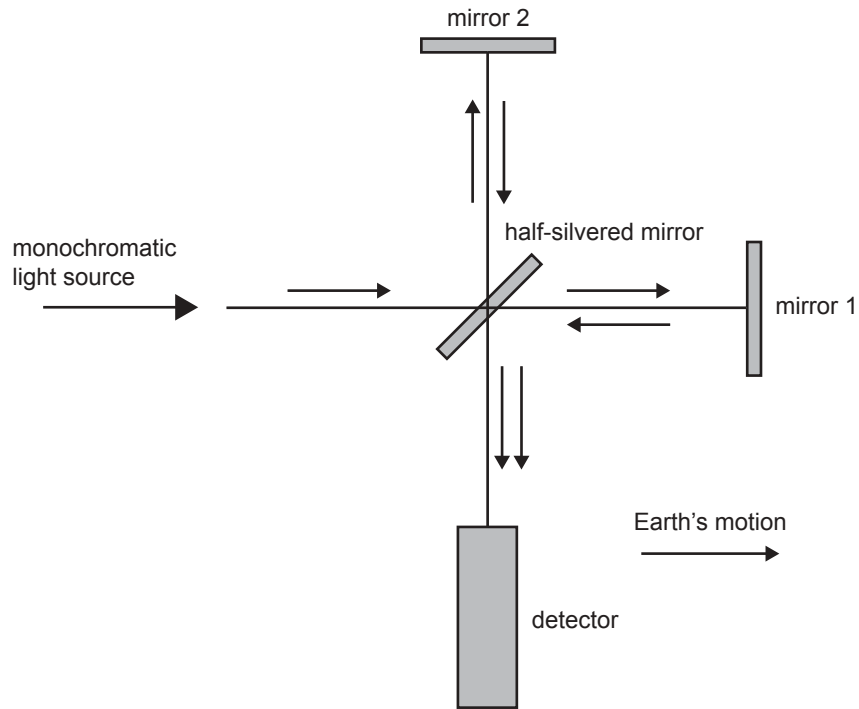

Figure 2

A simplified plan of their equipment is shown in Figure 2. The apparatus was set up so that light travelling towards mirror 2 was travelling perpendicular to the motion of Earth around the Sun, and light travelling towards mirror 1 was in the direction of Earth’s motion in its orbit. Michelson and Morely observed a fringe pattern at the detector resulting from interference between the two light beams. The measurement was then repeated with the apparatus turned through an angle of 90° , and no change was seen in the interference-fringe pattern after the rotation of the apparatus.

Question 4

Explain the significance of this null observation.

3 marks

One of the basic particles of nature is the *tau meson*, which can be created using beams of high energy particles from an accelerator. When created, the tau meson has a very high velocity of $0.998749 c$, which means it has a Lorentz factor of 20. However it only exists for a period of $6.10 \times 10^{-12} \text{ s}$ as measured by the scientists at the accelerator laboratory. After this time it decays into two other particles. During this time it is observed to travel a distance d . Figure 3 shows the creation and decay of the tau meson in the reference frame of the scientists.

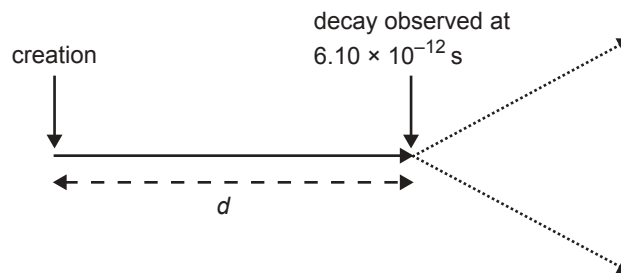

Figure 3

Question 5

What is the lifetime of the tau meson as measured in its own frame of reference?

 s

3 marks

Question 6

What is the distance d in Figure 3, as measured by the scientists?

 m

2 marks

Question 7

As measured in the reference frame of the tau meson, what would be the distance d ?

 m

3 marks

According to Einstein's special theory of relativity, mass and energy are related. The mass of an electron when it is at rest is 9.1×10^{-31} kg.

Question 8

Show that this is equivalent to an energy of 8.20×10^{-14} J.

2 marks

The electron accelerator at the ARPANSA laboratory at Yallambie, near Melbourne, can accelerate an electron to a speed such that its mass increases **by a factor of 22**.

Question 9

What is the value of the Lorentz factor for an electron as it leaves the accelerator?

2 marks

Question 10

Which of the following (A–D) gives the kinetic energy of the electron as it leaves the accelerator?

- A. 8.20×10^{-15} J
- B. 1.72×10^{-12} J
- C. 1.80×10^{-13} J
- D. 5.11×10^{-6} J

2 marks

Detailed study 2 – Investigating materials and their use in structures

Two physics students conduct an experiment to determine the properties of steel wire. Their sample of wire is 0.500 m long when unstretched, and has a cross-sectional area of $2.0 \times 10^{-8} \text{ m}^2$. With the arrangement shown in Figure 1, they make measurements of the length of the wire as they attach 1.0 kg masses to the wire.

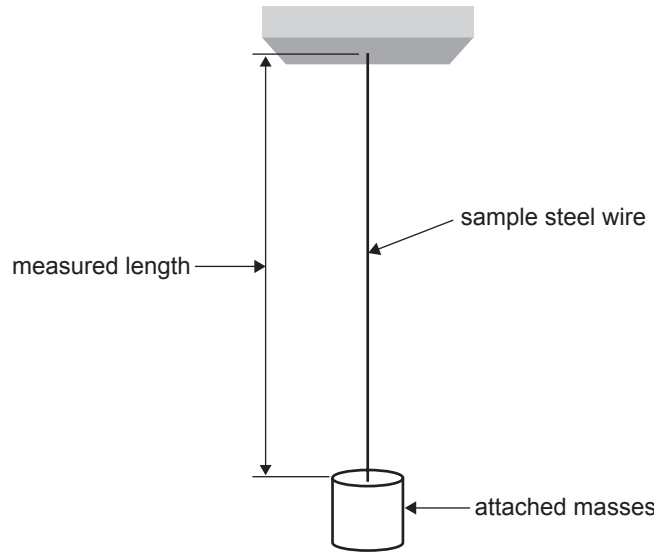

Figure 1

Their data is shown in the table below.

Number of 1.0 kg masses	0	1	2	3	4	5	6	7	8
Measured length (m)	0.500	0.502	0.504	0.506	0.508	0.510	0.514	0.519	*

The wire broke when the 8th mass was added.

Question 1

On the axes provided, plot a graph of tension in the wire versus the extension from the unstretched length of the wire. Label the axes and include units.

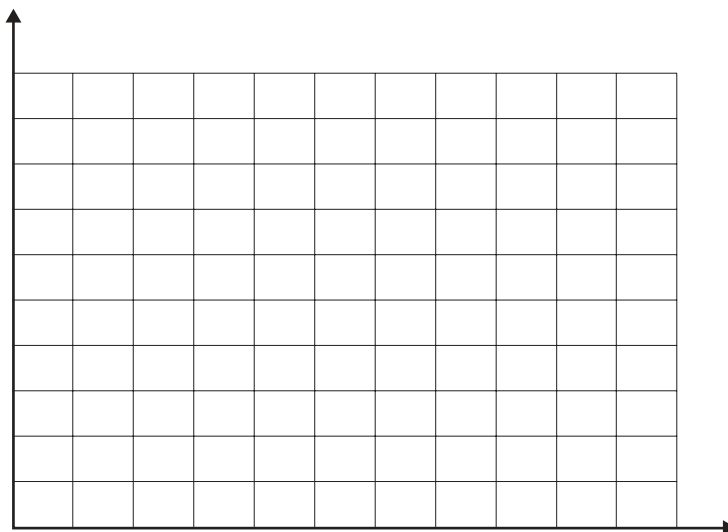

2 marks

Question 2

Which of the following values (**A–D**) gives the potential energy of the wire when it has 4 masses hanging from it?

- A. 0.016 J
- B. 0.16 J
- C. 0.32 J
- D. 16.0 J

2 marks

Question 3

What is the **stress** in the wire when it has 4 masses hanging from it? You must include the unit.

value	unit
-------	------

2 marks

Question 4

What is the value of Young's modulus for the material of the wire?

2 marks

Question 5

Which of the following values (**A–D**) is the best estimate of the elastic limit of the material of the wire?

- A. $1.0 \times 10^9 \text{ N m}^{-2}$
- B. $2.5 \times 10^9 \text{ N m}^{-2}$
- C. $4.0 \times 10^9 \text{ N m}^{-2}$
- D. $8.0 \times 10^9 \text{ N m}^{-2}$

2 marks

Question 6

Given the results of the experiment, would you consider the material to be brittle or ductile? Explain your answer.

2 marks

The Westgate Bridge (Figure 2) is known as a cable-stayed bridge. This means that the main span is supported by a number of strong steel cables.



Figure 2

Shown in Figure 3 is a schematic of such a bridge that shows only one set of cables.

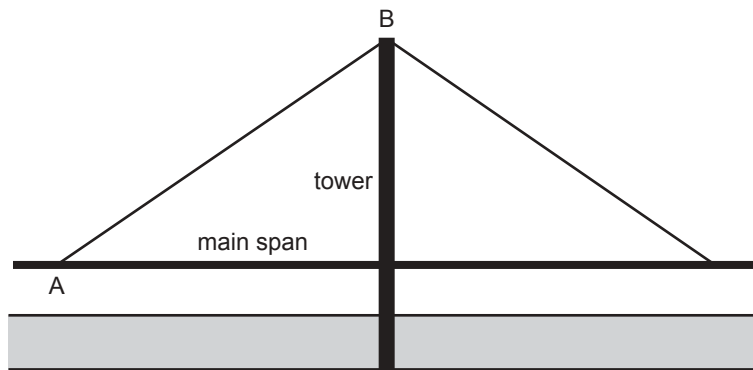

Figure 3

Question 7

On Figure 3 draw two arrows indicating the tension in the cable AB supporting the main span. Draw one arrow where it is attached to the top of the tower, and the other where it is attached to the deck of the main span.

2 marks

Figure 4 shows the region of the deck between the support cable and the support tower when it is heavily loaded with traffic. The figure is not to scale and the deformation of the deck is greatly exaggerated.

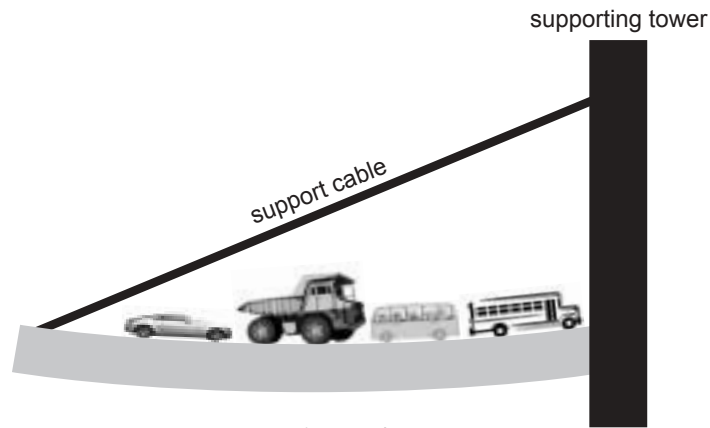
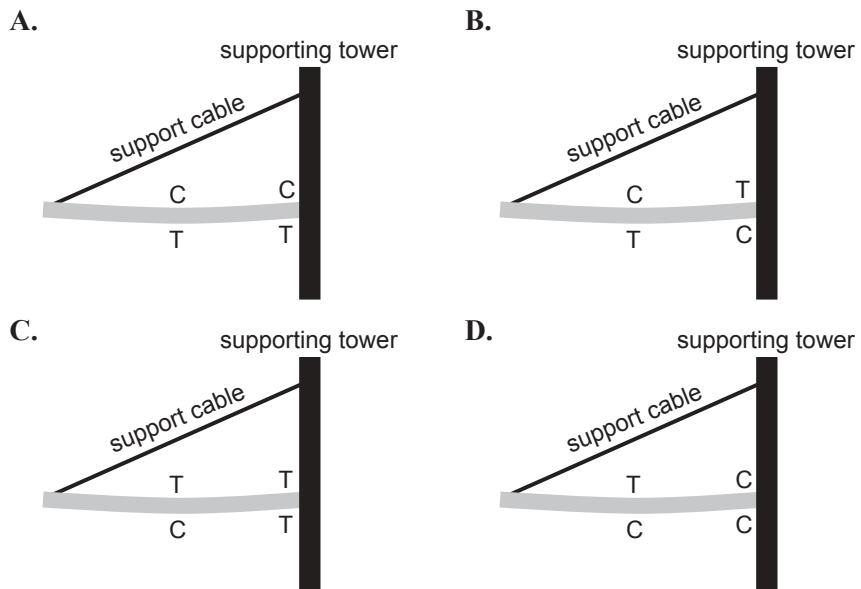

Figure 4

Question 8

Which of the diagrams (A–D) below best indicates which regions of the deck are in tension (T) and which are under compression (C) ?



2 marks

The main deck is made of a steel/concrete composite.

Question 9

Indicate which structural property of this composite material makes it suitable for this role.

2 marks

Alf the painter, who is not very safety conscious, is using a platform as shown in Figure 5 below. The mass of the platform is 200 kg and it is resting on a pedestal that is 1.0 m wide. The centre of mass (CM) of the platform is shown in the figure. Alf has a mass of 100 kg.

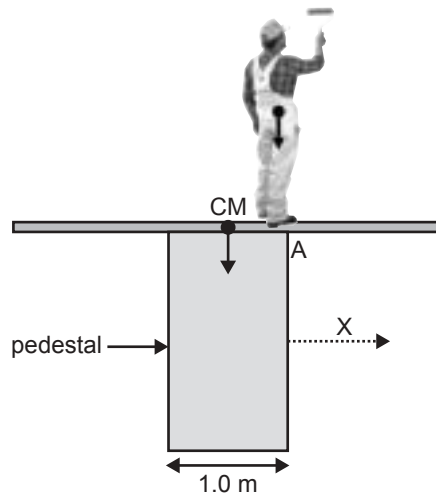

Figure 5

Question 10

What is the value of the **anticlockwise** torque (rotational effect of force) about point A due to the weight of the platform?

N m

2 marks

As Alf moves to the right, he provides a **clockwise** torque (rotational effect of force) **about point A**.

Question 11

What is the value of distance X, shown in Figure 5, where Alf will be when the platform begins to tip over?

m

3 marks

Question 12

If the height of the pedestal is increased, how will the value of distance X change?

- A. It will increase.
- B. It will not change.
- C. It will decrease.

2 marks

Detailed study 3 – Further electronics

Shown below in Figure 1 are all the components needed to construct a regulated DC power supply.

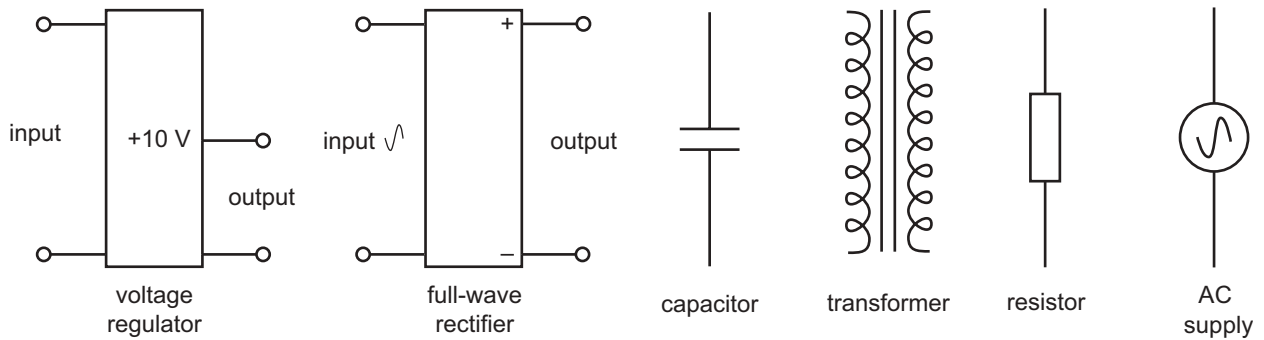

Figure 1

Question 1

Using the components shown in Figure 1, sketch below the circuit for a regulated 10 V DC power supply. All connections must be shown. The unit is to operate from a $240\text{ V}_{\text{RMS}}$ mains supply.

4 marks

Question 2

Which of the following values gives the best estimate of the peak-to-peak value of the $240\text{ V}_{\text{RMS}}$ input to this power supply?

- A. 679 V
- B. 480 V
- C. 339 V
- D. 170 V

2 marks

When connected to the $240\text{ V}_{\text{RMS}}$ mains supply, the transformer in your circuit design must provide an output of $10.6\text{ V}_{\text{RMS}}$.

Question 3

For this transformer, what is the value of the ratio $\frac{\text{number of turns on the output}}{\text{number of turns on the input}}$?

2 marks

Question 4

The figures below show the current for a full-wave bridge rectifier when the potential at X is positive with respect to Y. The grey-shaded arrows show the current directions at three points. Which one of the diagrams (A–D) correctly shows the path of the current?

A.

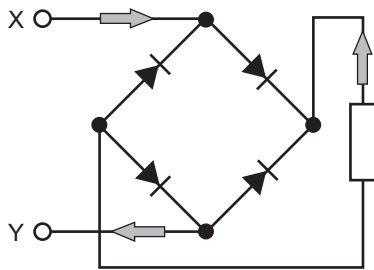

B.

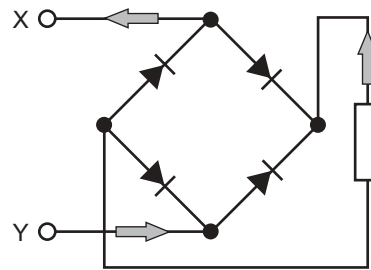

C.

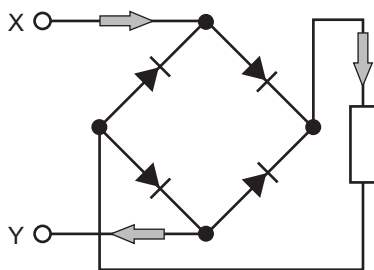

D.

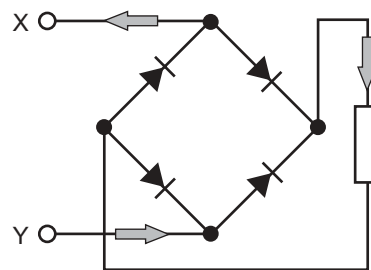

2 marks

All DC power supplies contain a smoothing-circuit component. In the simplest case this can be a capacitor of capacitance C . In the absence of a voltage regulator the load is connected directly across the capacitor. In this test circuit, the load is a resistor of resistance $R = 1.0 \text{ k}\Omega$. The test circuit is to have a time constant greater than 50 ms.

Question 5

Which of the values (A–D) of capacitor C will best ensure the time constant is greater than 50 ms?

- A. 60 pF
- B. 0.06 μF
- C. 6 μF
- D. 60 μF

2 marks

A simple voltage-regulator may be modelled as a resistor in series with a Zener diode as shown in Figure 2a. The Zener diode, as sketched in Figure 2b., may be assumed to be ‘ideal’. It has a Zener voltage of 10 V and a cut-in voltage of 0.7 V.

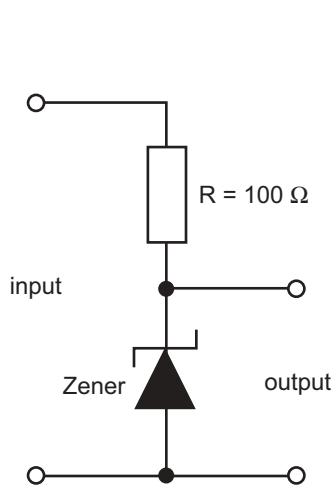

Figure 2a

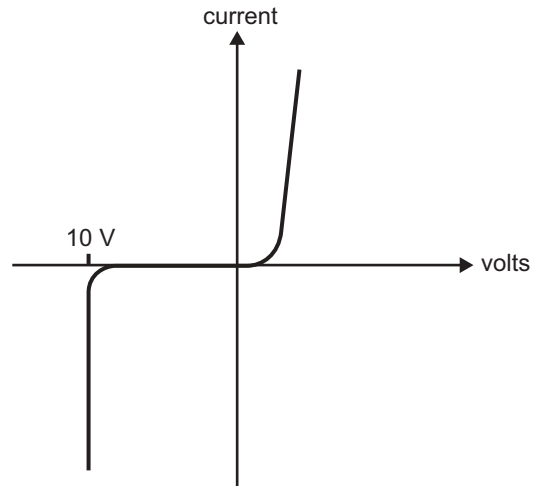

Figure 2b

Question 6

Explain why having the Zener diode reverse biased (that is oriented as Figure 2a) is critical to the operation of the circuit.

2 marks

In checking the voltages at various points in your circuit, you have the option of using an oscilloscope or a multimeter (either analogue or digital).

Question 7

Explain which you would use and why. To gain full marks, you must comment on measurement of both DC and AC voltages.

3 marks

For the remaining questions in this section you are to assume that the regulated DC power supply circuit which you drew in Question 1 has been wired up, checked, and is working correctly. With $240\text{ V}_{\text{RMS}}$ input the transformer output is $30\text{ V}_{\text{P-P}}$. Initially the load resistor has a resistance of $R_L = 1000\ \Omega$.

Question 8

The AC input voltage decreases by 5%.

Which one of the following statements is correct?

- A. The output voltage across the load resistor is virtually **unchanged**.
- B. The output voltage across the load resistor **decreases** by about 5%.
- C. The input voltage across the voltage regulator is virtually **unchanged**.
- D. The input voltage across the voltage regulator **increases** by about 5%.

2 marks

The input voltage is again set at $240 \text{ V}_{\text{RMS}}$. The 1000Ω load resistor is replaced by a 2000Ω resistor.

Question 9

Explain what effects (if any) this change has on the **voltage** across the load resistor and the **current** through the load resistor.

i. voltage _____

ii. current _____

2 marks

A heat sink is used to ensure components remain within their correct operating temperature range.

Question 10

Some of the components in the power supply may require a heat sink. Explain the purpose of a heat sink.

2 marks

Another student has successfully constructed a voltage regulated DC power supply using a half-wave rectifier in place of the full-wave bridge rectifier. All other components are identical. You compare the ripple voltages at the **input to the voltage regulators** and the maximum voltage at the loads in the two cases.

Question 11

Tick the box that identifies the change.

increases

**remains
the same**

decreases

The input ripple voltage across the voltage regulator

2 marks

PHYSICS

Written examination 1

DATA SHEET

Directions to students

Detach this data sheet before commencing the examination.

This data sheet is provided for your reference.

1	velocity; acceleration	$v = \frac{\Delta x}{\Delta t}; \quad a = \frac{\Delta v}{\Delta t}$
2	equations for constant acceleration	$v = u + at$ $x = ut + \frac{1}{2}at^2$ $v^2 = u^2 + 2ax$ $x = \frac{1}{2}(v + u)t$
3	Newton's second law	$F = ma$
4	circular motion	$a = \frac{v^2}{r} = \frac{4\pi^2 r}{T^2}$
5	Hooke's law	$F = -kx$
6	elastic potential energy	$\frac{1}{2}kx^2$
7	gravitational potential energy near the surface of the Earth	mgh
8	kinetic energy	$\frac{1}{2}mv^2$
9	Newton's law of universal gravitation	$F = G \frac{M_1 M_2}{r^2}$
10	gravitational field	$g = G \frac{M}{r^2}$
11	stress	$\sigma = \frac{F}{A}$
12	strain	$\varepsilon = \frac{\Delta L}{L}$
13	Young's modulus	$E = \frac{\text{stress}}{\text{strain}}$
14	transformer action	$\frac{V_1}{V_2} = \frac{N_1}{N_2}$
15	AC voltage and current	$V_{\text{RMS}} = \frac{1}{2\sqrt{2}} V_{\text{p-p}} \quad I_{\text{RMS}} = \frac{1}{2\sqrt{2}} I_{\text{p-p}}$
16	voltage; power	$V = RI \quad P = VI$

17	resistors in series	$R_T = R_1 + R_2$
18	resistors in parallel	$\frac{1}{R_T} = \frac{1}{R_1} + \frac{1}{R_2}$
19	capacitors	time constant : $\tau = RC$
20	Lorentz factor	$\gamma = \frac{1}{\left(1 - \frac{v^2}{c^2}\right)^{\frac{1}{2}}}$
21	time dilation	$t = t_0 \gamma$
22	length contraction	$L = L_0 / \gamma$
23	relativistic mass	$m = m_0 \gamma$
24	universal gravitational constant	$G = 6.67 \times 10^{-11} \text{ N m}^2 \text{ kg}^{-2}$
25	mass of Earth	$M_E = 5.98 \times 10^{24} \text{ kg}$
26	radius of Earth	$R_E = 6.37 \times 10^6 \text{ m}$
27	mass of the electron	$m_e = 9.1 \times 10^{-31} \text{ kg}$
28	charge on the electron	$q = -1.6 \times 10^{-19} \text{ C}$
29	speed of light	$c = 3.0 \times 10^8 \text{ m s}^{-1}$

Prefixes/Units

p = pico = 10^{-12}

n = nano = 10^{-9}

μ = micro = 10^{-6}

m = milli = 10^{-3}

k = kilo = 10^3

M = mega = 10^6

G = giga = 10^9

1 tonne = 10^3 kg

END OF DATA SHEET