



**Victorian Certificate of Education
2007**

SUPERVISOR TO ATTACH PROCESSING LABEL HERE

STUDENT NUMBER

Letter

Figures
Words

--

**PHYSICS
Written examination 1**

Tuesday 12 June 2007

Reading time: 11.45 am to 12.00 noon (15 minutes)

Writing time: 12.00 noon to 1.30 pm (1 hour 30 minutes)

QUESTION AND ANSWER BOOK

Structure of book

<i>Section</i>	<i>Number of questions</i>	<i>Number of questions to be answered</i>	<i>Number of marks</i>
A – Core – Areas of study			
1. Motion in one and two dimensions	17	17	40
2. Electronics and photonics	11	11	25
B – Detailed studies			
1. Einstein’s special relativity (page 18)	10	10	25
OR			
2. Investigating materials and their use in structures (page 24)	10	10	25
OR			
3. Further electronics (page 29)	12	12	25
			Total 90

- Students are permitted to bring into the examination room: pens, pencils, highlighters, erasers, sharpeners, rulers, up to two pages (one A4 sheet) of pre-written notes (typed or handwritten) and one scientific calculator.
- Students are NOT permitted to bring into the examination room: blank sheets of paper and/or white out liquid/tape.

Materials supplied

- Question and answer book of 35 pages with a detachable data sheet in the centrefold.

Instructions

- Detach the data sheet from the centre of this book during reading time.
- Write your **student number** in the space provided above on this page.
- Answer all questions in the spaces provided.
- **Always** show your working where space is provided.
- Where an answer box has a unit printed in it, give your answer in that unit.
- All written responses must be in English.

Students are NOT permitted to bring mobile phones and/or any other unauthorised electronic devices into the examination room.

SECTION A – Core**Instructions for Section A**

Answer **all** questions **for both** Areas of study in this section.

For all questions which require a numerical answer you must show all working.

You should take the value of g to be 10 m s^{-2} .

Area of study 1 – Motion in one and two dimensions

Fred is riding his bike on a level road at a speed of 5.0 m s^{-1} . The tail-light breaks off. It takes 0.45 s to reach the ground.

Question 1

How far above the ground was the tail-light when it was attached?

m

2 marks

Mary was watching Fred and saw the tail-light fall. Her view of the events is shown in Figure 1 below. Fred was at position A when the tail-light broke off, and at position B when it hit the ground.

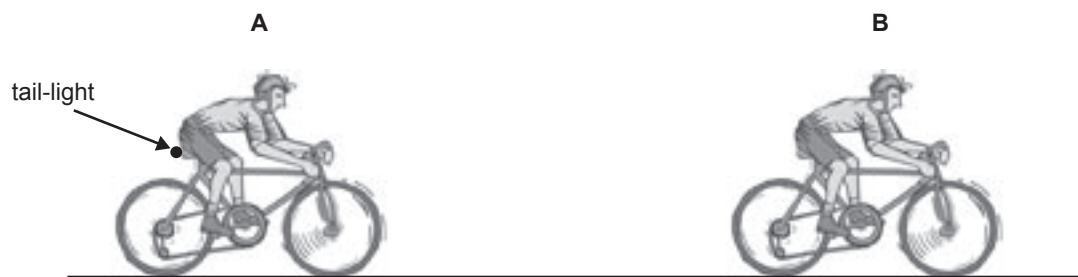
**Figure 1****Question 2**

On Figure 1 sketch the path of the tail-light **as seen by Mary**, and indicate the final position of the tail-light.

2 marks

Meredith and Hilary are studying collisions by sliding blocks together on a frictionless table. Meredith slides a block of mass 2 kg with a speed of 3 m s^{-1} that collides with a block of mass 1 kg, which was at rest. After the collision the 1 kg block has a speed of 4 m s^{-1} . The situations before and after are shown in Figure 2.



Figure 2

Question 3

Show that, after the impact, the velocity of the 2 kg block is 1 m s^{-1} .

2 marks

Question 4

Indicate in the box below whether this is an example of an elastic or inelastic collision. Include calculations to justify your answer.

3 marks

Question 5

What average force does the 2 kg block exert on the 1 kg block during the contact time of 0.01 s?

3 marks

Amelia, who has a mass of 60 kg including equipment, is skydiving. The air resistance on her as a function of the distance fallen is shown in Figure 3. After falling a distance of 400 m, she has reached terminal velocity, and continues to fall at a constant speed until she opens her parachute.

Due to copyright restriction,
this material is not supplied.

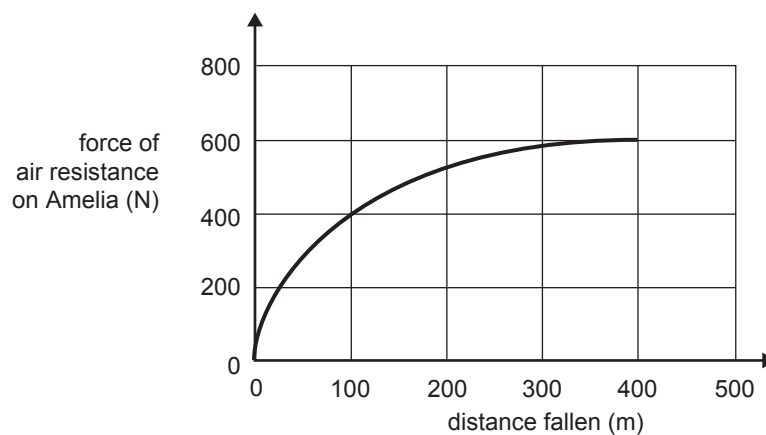

Figure 3

Question 6

What is the magnitude of the **net** force on Amelia after falling 400 m?

2 marks

Question 7

Calculate her acceleration when she has fallen 100 m.

3 marks

Question 8

Estimate the work done by the air-resistance force on Amelia while she was falling 500 m from the plane.

J

2 marks

In a laboratory class at school, Lee is given a spring with a stiffness of 20 N m^{-1} and unstretched length of 0.40 m . He hangs it vertically, and attaches a mass to it, so that the new length of the spring is 0.60 m .

Question 9

Assuming the spring has no mass, what was the value of the mass he attached?

3 marks

Lee pulls the mass down a further distance of 0.10 m .

Question 10

By how much has the potential energy stored in the spring changed?

3 marks

He now releases the mass, so that the mass-spring system oscillates. Ignore air resistance.

Question 11

Which one of the curves (A–D) below could best represent the variation of the **total energy** of the oscillating mass-spring system as a function of position?

A.

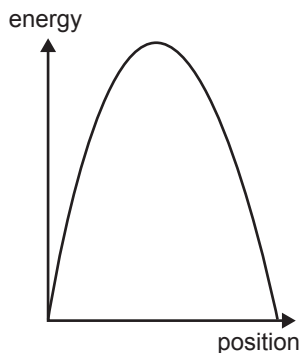

B.

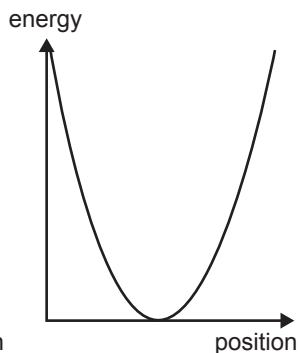

C.

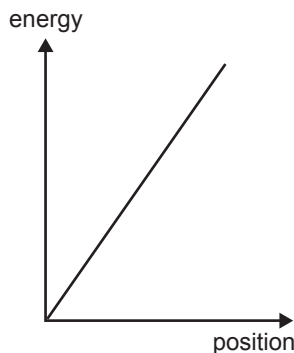

D.

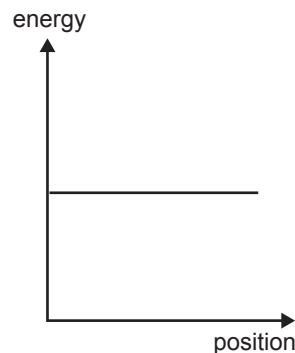

2 marks

The dwarf planet Pluto was discovered in 1930, and was thought to be the outermost member of our solar system. It can be considered to orbit the Sun in a circle of radius 6 billion kilometres (6.0×10^{12} m). In 2003 a new dwarf planet, Eris, was discovered. It has approximately the same mass as Pluto, but the average radius of its orbit around the Sun is 10.5 billion kilometres (10.5×10^{12} m).

Question 12

Which of the choices (A–D) below gives the best estimate of the ratio

$$\frac{\text{gravitational attraction of the Sun on Eris}}{\text{gravitational attraction of the Sun on Pluto}} ?$$

- A. 0.33
- B. 0.57
- C. 1.75
- D. 3.06

2 marks

The period of Pluto around the Sun is 248 Earth-years.

Question 13

How many Earth-years does Eris take to orbit the Sun?

 years

2 marks

Daniel and John are playing paintball. Daniel fires a 'paintball' at an angle of 25° to the horizontal and a speed of 40.0 m s^{-1} . The paintball hits John, who is 127 m away. The height at which the ball hits John and the height from which the ball was fired are the same. The situation is shown in Figure 4.

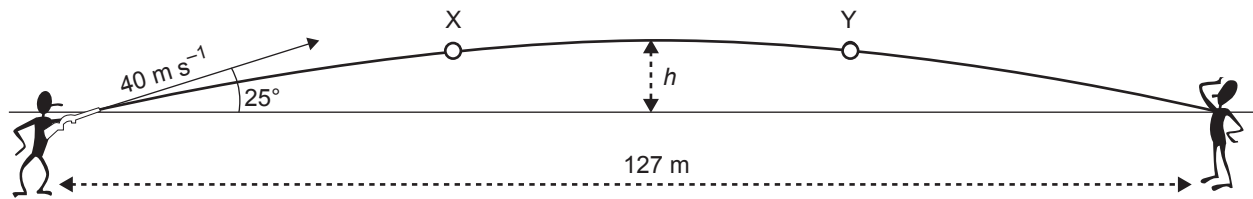

Figure 4

The acceleration due to gravity should be taken as 10 m s^{-2} , and air resistance should be ignored.

Question 14

What is the time of flight of the paintball?

2 marks









Question 15

What is the value of h , the maximum height above the firing level?

3 marks

Question 16

Which of the following diagrams (A–D) below gives the direction of the force acting on the paintball at points X and Y respectively?

- | | at point X | at point Y |
|----|---|---|
| A. |  |  |
| B. |  |  |
| C. |  |  |
| D. |  |  |

2 marks

Later in the game, Daniel is twice as far away from John (254 m). John fires an identical paintball from the same height above the ground as before. The ball hits Daniel at the same height as before. In both cases the paintball reaches the same maximum height (h) above the ground.

Question 17

Which **one or more** of the following is the same in both cases?

- A. flight time
- B. initial speed
- C. acceleration
- D. angle of firing

2 marks

Area of study 2 – Electronics and photonics

The circuit diagram for an npn transistor amplifier is shown in Figure 1.

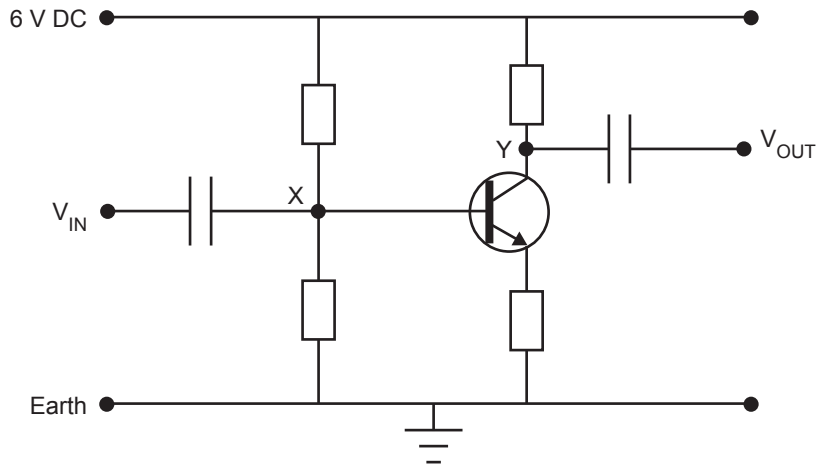

Figure 1

With no input signal, the voltage above Earth at point X is measured to be 1.0 V, and at point Y it is 3.0 V. The transistor circuit has a voltage amplification of 80.

The signal shown in Figure 2a is applied between V_{IN} and Earth.

Question 1

On the axes provided in Figure 2b, sketch the output signal between V_{OUT} and Earth. **You must include a unit and scale on the vertical axis.**

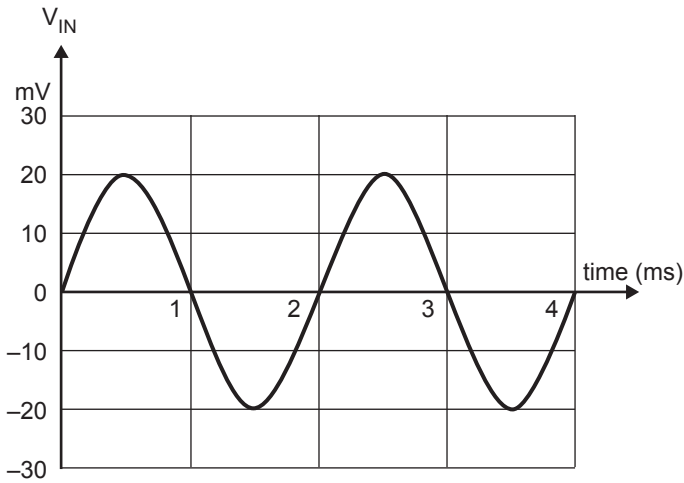

Figure 2a

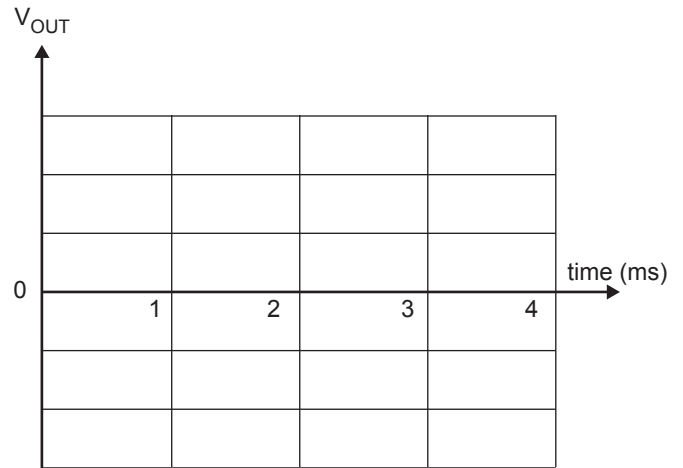

Figure 2b

2 marks

Remember that with no input signal, the DC voltage at point Y is 3.0 V.

The input signal, V_{IN} , is increased to 240 mV (peak to peak) as shown in Figure 3a.

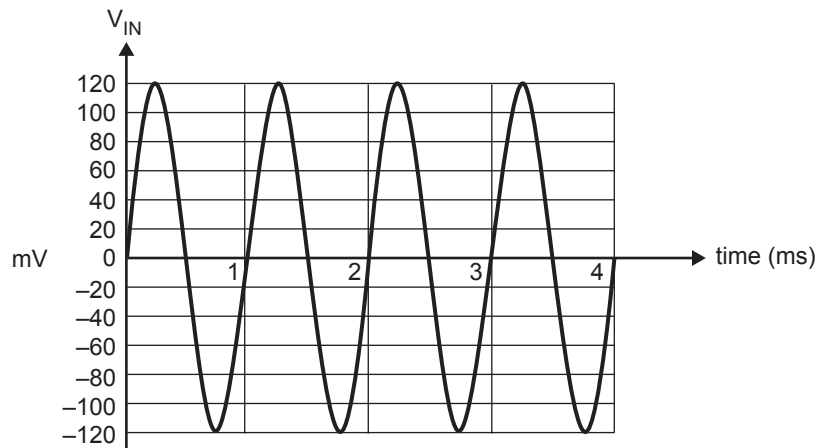

Figure 3a

Question 2

On the set of axes shown in Figure 3b, sketch the output signal you would now expect to see. You must include a unit and scale on the vertical axis.

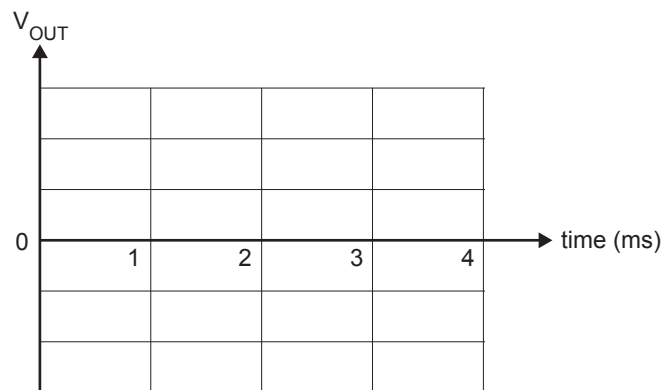

Figure 3b

2 marks

The input signal is now increased to 3.0 V (peak to peak). A student tells the class that **saturation** will now occur.

Question 3

In the space below explain the meaning of the term **saturation**, how it affects the operation of the transistor, and its effect on the output signal.

3 marks

A capacitor consists of two conducting plates separated by an insulator. When used in an electronics circuit it allows AC signals to pass through, but blocks DC.

Question 4

Which of the following statements (A–D) best describes how the capacitor achieves this?

- A. AC current passes through the insulating medium between the two plates.
- B. For each AC cycle as one plate becomes positively charged the other becomes negatively charged. This alternates for each cycle.
- C. The current in one plate induces an alternating current in the other plate, but DC cannot induce current, as this needs a changing magnetic flux.
- D. The insulating medium breaks down under AC, but retains its resistance under DC.

2 marks

The current-voltage characteristic of a light emitting diode (LED) is shown in Figure 4.

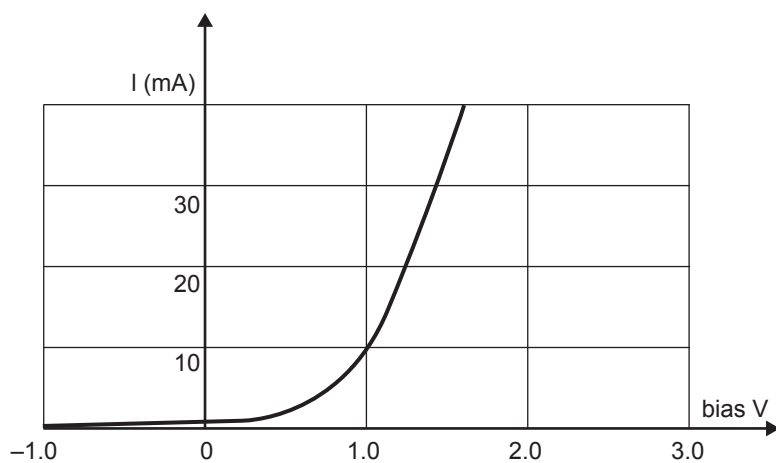

Figure 4

Using this LED, students set up the circuit shown in Figure 5.

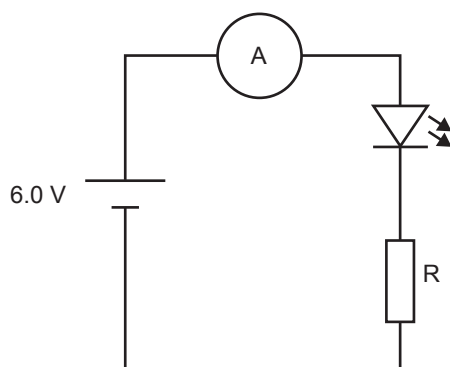

Figure 5

Question 5

The current measured by the ammeter is 10 mA. What is the value of the resistor, R?

Ω

3 marks

The LED is now reversed.

Question 6

What is the voltage across the diode now?

Explain your answer.

V

3 marks

A light dependent resistor (LDR) has the characteristics shown in Figure 6.

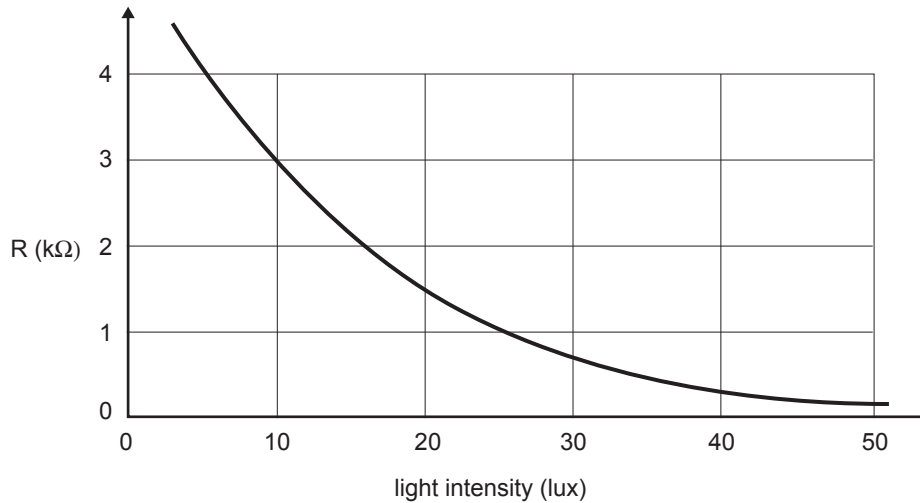

Figure 6

In a measurement of the light intensity in a classroom, a student measures the resistance of the LDR to be 3000 ohm.

Question 7

What is the intensity of the light falling on the LDR?

lux

2 marks

A circuit is set up to switch on a light when the illumination in the room drops below 20 lux. The light comes on when the voltage across V_{OUT} reaches 4.0 V.

The circuit is shown in Figure 7 below.



Figure 7

Question 8

What should be the value of the resistor, R, for the circuit to operate correctly?

Ω

2 marks

The class decides that the room is too dark before the light comes on. The teacher wishes to reset the system so that the light comes on before the classroom becomes so dark.

Question 9

In the space below indicate whether the value of R should be increased or decreased to achieve this. Explain your answer.

2 marks

Figure 8a, below, shows a schematic diagram for an intensity-modulated fibre-optic link that is used to transmit an audio signal.

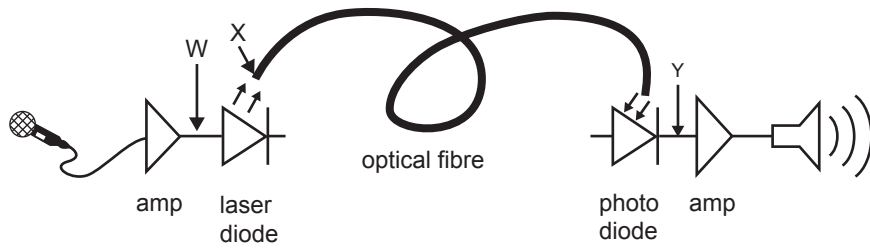

Figure 8a

To test the device an audio signal is fed into the microphone. The signal at point W is shown in Figure 8b.

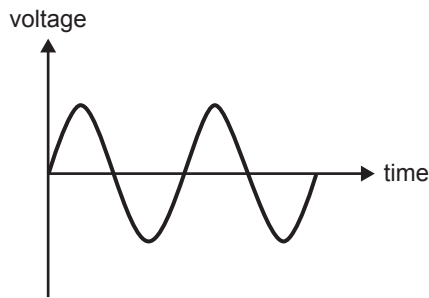
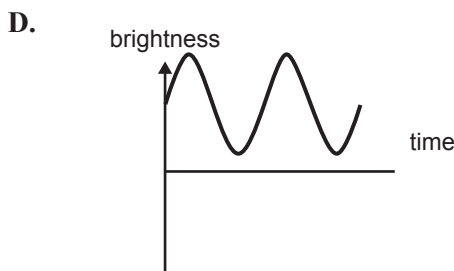
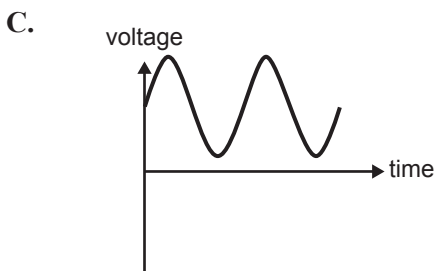
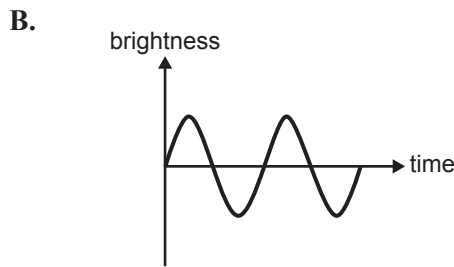
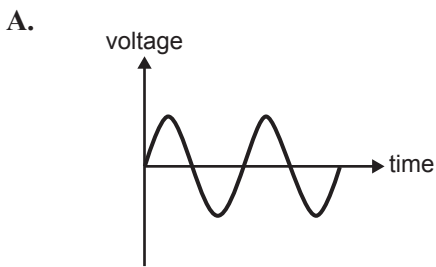

Figure 8b

Question 10

Which of the diagrams (A–D) below best represents the signal observed at point X in Figure 8a?



2 marks

Question 11

Which of the diagrams (A–D) above could represent the signal that would be observed at point Y in Figure 8a?

2 marks

**END OF SECTION A
TURN OVER**

SECTION B – Detailed studies**Instructions for Section B**

Choose **one** of the following **Detailed studies**. Answer **all** the questions on the Detailed study you have chosen.

For all questions which require a numerical answer you must show all working.

You should take the value of g to be 10 m s^{-2} .

Detailed study 1 – Einstein’s special relativity**Question 1**

Complete the following sentences by circling the correct word from the choice of three that is given within each bracket.

Michelson and Morley performed an experiment to measure the speed of
[**Earth / light / Earth’s rotation**] relative to the ether. Monochromatic light from a single
source was split into two beams: one that travelled perpendicular to, and one normal to,
Earth’s motion. On recombination a/an [**diffraction / interference / refraction**] pattern
was observed. Michelson and Morley concluded that there was [**no / significant/ major**]
evidence to support the existence of the ether.

3 marks

A plane travelling relative to the air at a speed of 170 m s^{-1} is 3.00 km from the control tower. The plane is late because of a headwind of 50 m s^{-1} . To let the control tower know that the plane is nearby, the pilot sounds a siren which sends a high frequency sound pulse towards the control tower. The speed of sound in air is 340 m s^{-1} .

Question 2

How long does it take for the sound to reach the control tower?

3 marks

A spacecraft is approaching Earth at a speed of $0.1000 c$. When the pilot measures the distance to the control tower to be $90\,000 \text{ km}$ ($9.0000 \times 10^7 \text{ m}$), a signal is sent to inform the control tower of the spacecraft's approach. The speed of light can be taken as $3.000 \times 10^8 \text{ m s}^{-1}$.

Question 3

Which of the options (A–D) below is the best estimate of the time it takes the signal to reach the control tower, according to the pilot?

- A. 0.290 s
- B. 0.300 s
- C. 0.310 s
- D. 3.000 s

2 marks

Question 4

What is the value of the Lorentz factor for the approaching spacecraft?

2 marks

Ann and Bill are travelling in space in identical spaceships as shown in Figure 1 below. Ann knows that each spaceship is of proper length L_0 . At some time Ann observes Bill's ship passing her with a speed v , and she measures its length.

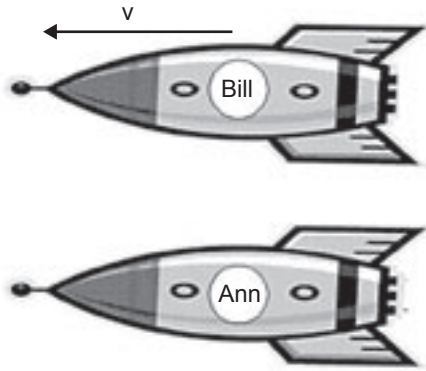

Figure 1

Question 5

Which of the following (A–D) best represents the length (L) of Bill's ship as measured by Ann?

- A. $L = \frac{L_0}{\sqrt{1 - v^2/c^2}}$
- B. $L = L_0 \sqrt{1 - v^2/c^2}$
- C. $L = \frac{L_0}{\sqrt{1 + v^2/c^2}}$
- D. $L = L_0 \sqrt{1 + v^2/c^2}$



2 marks

Ann, who is studying VCE physics, thinks about this. If she measures Bill's ship larger than L_0 , then he must measure hers as smaller than L_0 . Conversely, if Ann measures Bill's ship smaller than L_0 , then Bill must measure Ann's as larger than L_0 .

Question 6

Is Ann's reasoning correct? Write your answer in the box provided, and in the space below explain the logic of your answer.

3 marks

The Global Positioning System (GPS) is commonly used to locate positions on Earth. A highly accurate clock on board each orbiting satellite continually broadcasts the time to GPS receivers on Earth. Each GPS receiver has a clock that is assumed to be **identical** to that on the satellite. Over a period of exactly 24 hours the total time difference between the clock in the orbiting satellite and the clock in the GPS receiver is not zero, but 0.000038 s.



GPS satellite in orbit

Question 7

Assuming this time difference is due to special relativity, which **one or more** of the following statements is correct?

- A. The GPS receiver measures the satellite clock running at the same rate as itself.
- B. The GPS receiver measures the satellite clock running more slowly than itself.
- C. The GPS receiver measures the satellite clock running faster than itself.
- D. The orbit radius of the satellite is shortened due to relativity.

2 marks

One of the several subatomic particles produced in a historic experiment at the SACLAY research laboratory in France was a pi-minus (or pion). The pion had a very high speed, v , corresponding to a **Lorentz factor of 16**. From the data, the experimenters determined that the pion existed for 4.16×10^{-7} s before decaying into two other particles.

Question 8

Which of the options (A–D) below is the best estimate of how long the pion existed, as measured in its own frame of reference?

- A. 2.60×10^{-8} s
- B. 1.04×10^{-7} s
- C. 4.16×10^{-7} s
- D. 6.65×10^{-6} s

2 marks

Question 9

From the known Lorentz factor, show that the average speed of the pion was 0.998 c .

3 marks

The Sun produces energy by fusing light elements such as helium into heavier elements. In this fusion process mass is lost. The Sun radiates energy at a rate of 4.0×10^{26} W.

Question 10

How much mass does the Sun lose each second?

3 marks

Detailed study 2 – Investigating materials and their use in structures

Question 1

Complete the following sentences by circling the correct word from the choice of three that is given within each bracket.

When we apply a tensile stress to a solid body, we change its

[**compressibility** / **flexibility** / **length**]. A stress that acts to slide one atomic layer of a material over another is called a [**compressive** / **shear** / **surface**] stress. The gradient of the stress-strain graph is always a measure of the body's [**elasticity** / **brittleness** / **strength**].

3 marks

Figure 1 shows a suspended bird-watching platform that allows the viewers to look down on the top of the trees. It consists of a uniform concrete beam of length L and mass M which is suspended by two strong steel cables.

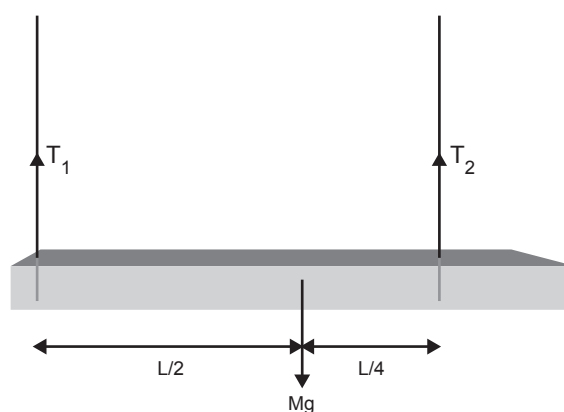

Figure 1

In order to ensure that the stress in the cables is well below their breaking point, it is important to know the values of the tensions T_1 and T_2 .

Question 2

Knowing that $T_2 = Mg - T_1$, and by considering the turning effect of the forces acting on the beam (about the cable with tension T_2), show that $T_1 = \frac{1}{3}Mg$.

3 marks

Question 3

The tension T_2 can be written as $T_2 = xT_1$.

What is the value of 'x'?

2 marks

Steel reinforcing bars are placed in the concrete beam to prevent it from cracking.

Question 4

Which of the following diagrams (A–D) shows the best placement of the steel reinforcing rods (represented by the pairs of thick black lines) in order to provide optimum strength?



2 marks

Cast iron and mild steel are two types of steel. Their stress-strain graphs are shown in Figure 2.

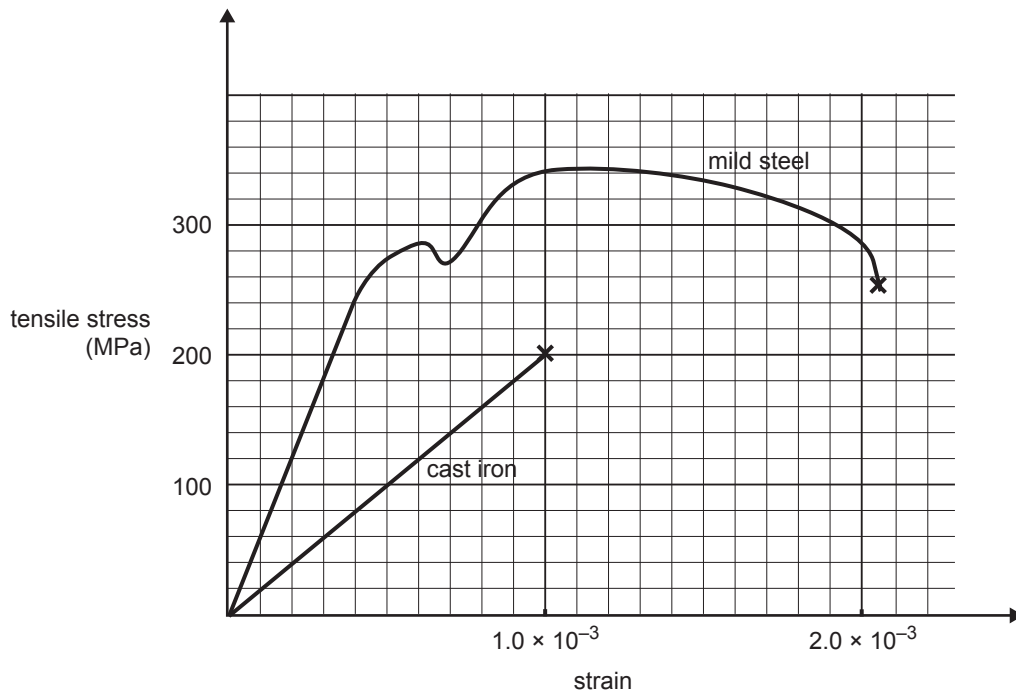

Figure 2

If you tap a cast iron object or a mild steel object **gently** with a hammer, the hammer bounces off.

Question 5

Which one of the statements below explains this?

- A. The two objects are brittle.
- B. The two objects are elastic.
- C. The mild steel object is brittle and the cast iron one is elastic.
- D. The mild steel object is elastic and the cast iron one is brittle.

2 marks

However, if you hit the objects really hard with the hammer, the cast iron object shatters, but the mild steel one will deform.

Question 6

Which of the statements below best explains this behaviour for the high-stress situation provided by the hammer blow?

- A. Both objects are stressed beyond their elastic limit.
- B. The cast iron object is stressed beyond its elastic limit, but the mild steel object is not.
- C. The cast iron object is stressed beyond its breaking point, and the mild steel object is stressed beyond its elastic limit.
- D. Both objects are stressed beyond their breaking point.

2 marks

A circular rod with a length of 1.0 m and diameter of 10 mm is made from the mild steel as shown in Figure 2. This rod is placed under tension with a stress of **240 MPa**.

Question 7

What force must be applied to the rod to provide this stress?

3 marks

Question 8

Calculate the total strain energy stored in the rod when this stress is applied.

3 marks

A street lamp of mass 20 kg is supported by a cable, AB, and a rigid rod, BC. Assume the mass of both the rod and wire is negligible. The rod (which you should assume is straight) is hinged at C, and makes an angle of 30° to the light pole, as shown in Figure 3.

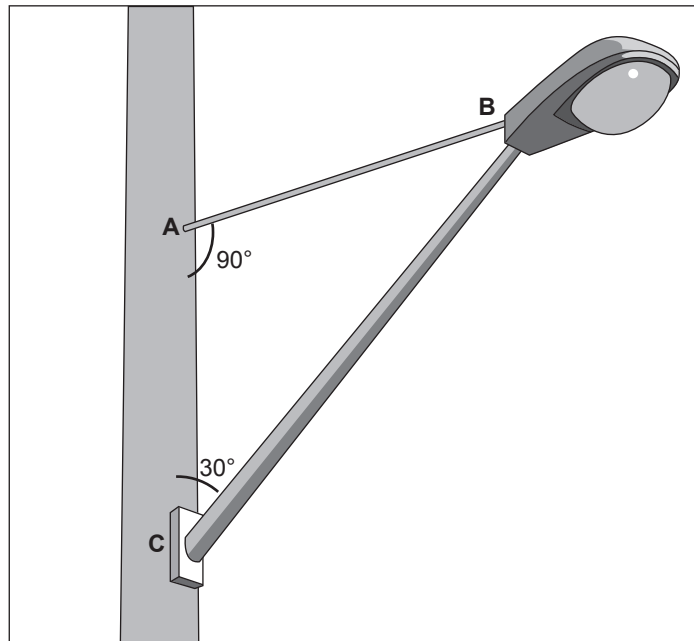

Figure 3

Question 9

Which of the statements (A–D) below is correct?

- A. Both the cable and the rod are under compression.
- B. Both the cable and the rod are under tension.
- C. The cable is under compression while the rod is under tension.
- D. The cable is under tension while the rod is under compression.

2 marks

Question 10

Calculate the magnitude of the force in the cable AB.

3 marks

Detailed study 3 – Further electronics

Question 1

Complete the following sentences by circling the correct word from the choice of three that is given within each bracket.

An audio amplifier needs a DC power supply in order to operate. Unfortunately the supply has an AC ripple component. The magnitude of the ripple voltage is best measured using [a multimeter set on DC amps / an oscilloscope / a DC voltmeter]. The effect of excessive ripple voltage is likely to cause [overheating / undervoltage / an audible hum] in the amplifier. The ripple voltage can be reduced by connecting a [capacitor / load resistor / diode-bridge rectifier] across the output of the power supply.

3 marks

A particular piece of apparatus requires an AC voltage of $6.0 V_{\text{RMS}}$. A transformer is used to provide this output from the $240 V_{\text{RMS}}$ AC mains.

Question 2

Which of the options (A–D) below gives the correct value for the ratio

$$\frac{\text{number of turns on the transformer secondary}}{\text{number of turns on the transformer primary}} ?$$

- A. $\frac{1200}{21}$
 B. $\frac{21}{1200}$
 C. $\frac{30}{1200}$
 D. $\frac{1200}{30}$

2 marks

A full-wave bridge rectifier is to be used in a circuit that produces DC from an AC input.

Question 3

Which of the following circuits would be most suitable?

A.

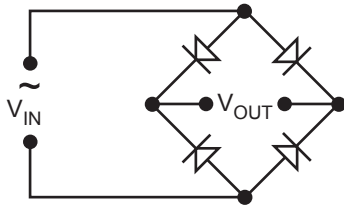

B.

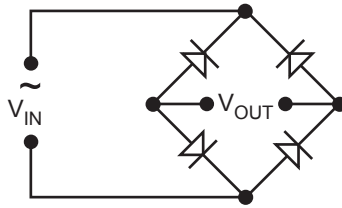

C.

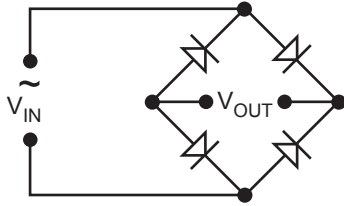

D.

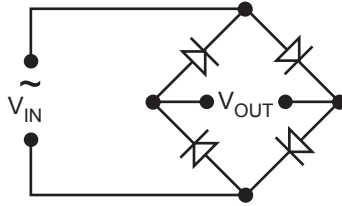

2 marks

Question 4

With the rectifier correctly connected and functioning, which of the following signals would be observed if an oscilloscope was connected across the output (V_{OUT}) of the bridge rectifier?

A.

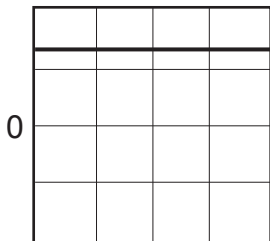

B.

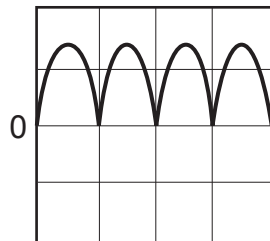

C.

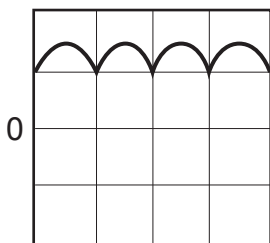

D.

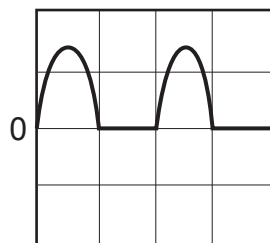

2 marks

A capacitor is charged to 12 V. It is then discharged through a $100\ \Omega$ resistor. The voltage across the capacitor, as a function of time, is shown in Figure 1 below.

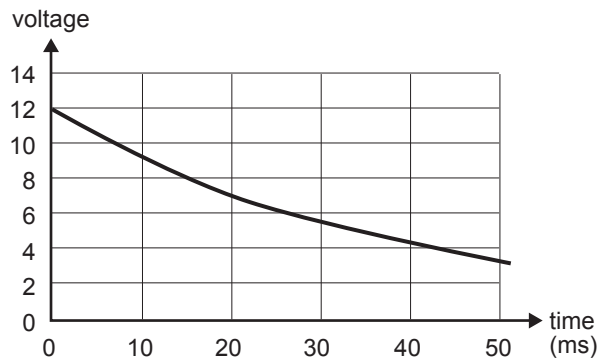

Figure 1

Question 5

Estimate the value of the capacitor.

μF

2 marks

A half-wave rectifier is shown in Figure 2a. The voltage across the $100\ \Omega$ load resistor is shown in Figure 2b.

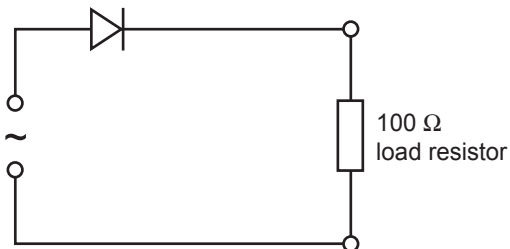

Figure 2a

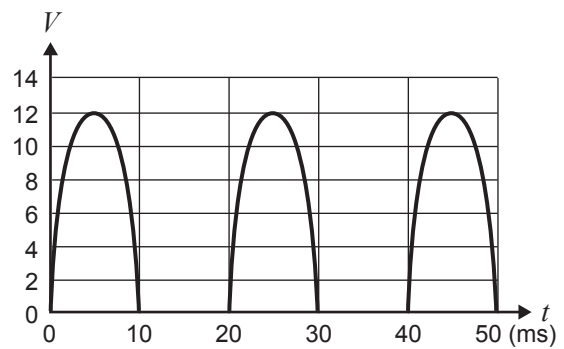

Figure 2b

The capacitor is added to the circuit to provide smoothing, as shown in Figure 3.

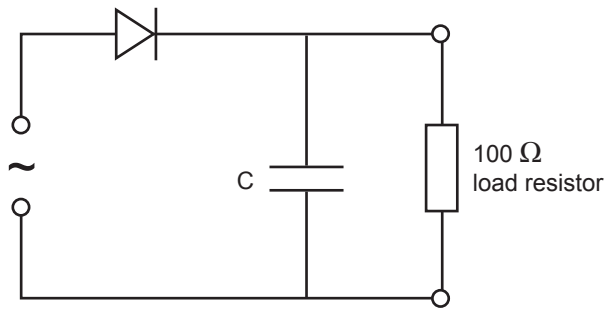
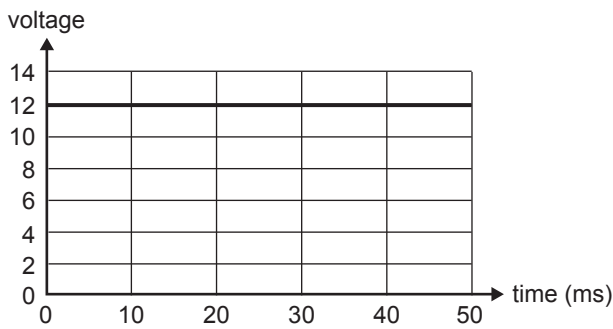

Figure 3

Question 6

Which of the figures (A–D) below best represents the voltage across the load resistor in Figure 3?

A.



B.

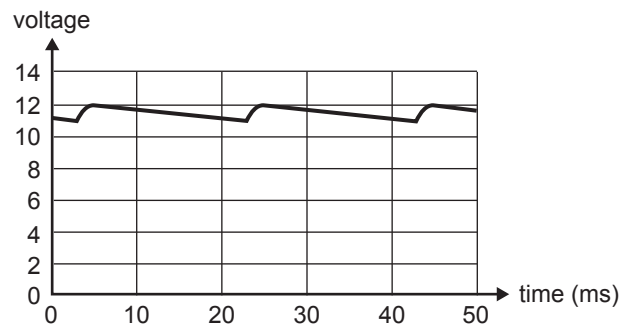

C.

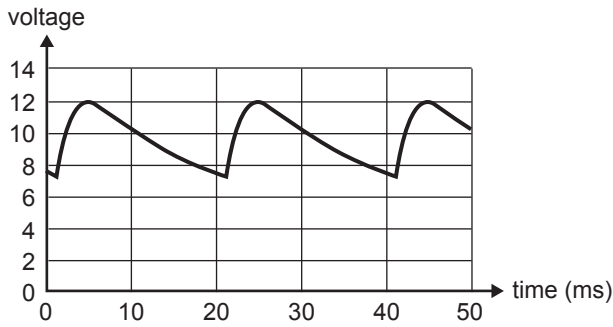

D.

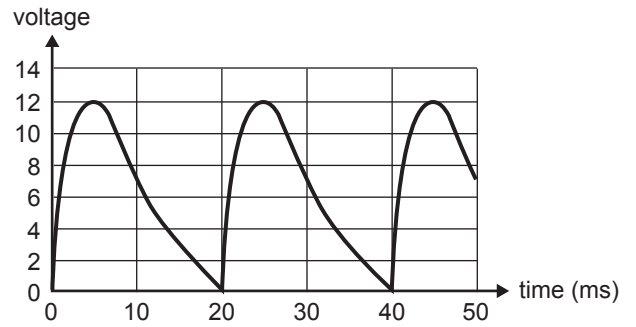

2 marks

Students are constructing a regulated DC power supply, and propose to use a Zener diode as the voltage regulator. The Zener diode characteristic is shown in Figure 4.

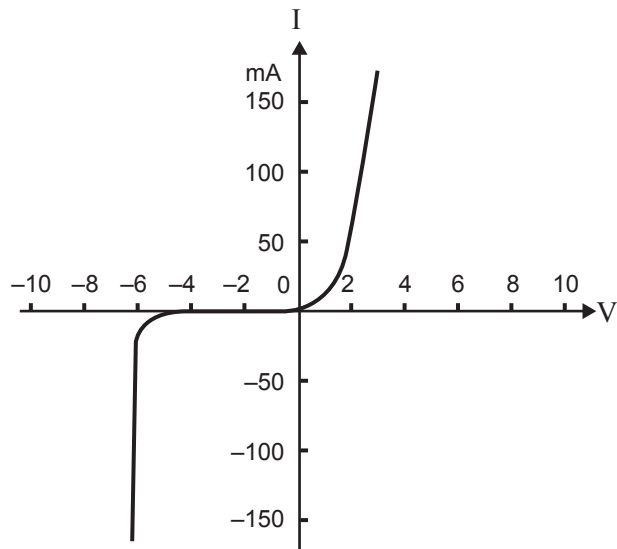

Figure 4

To test the Zener diode they connect a 9 V DC supply to the circuit shown in Figure 5.

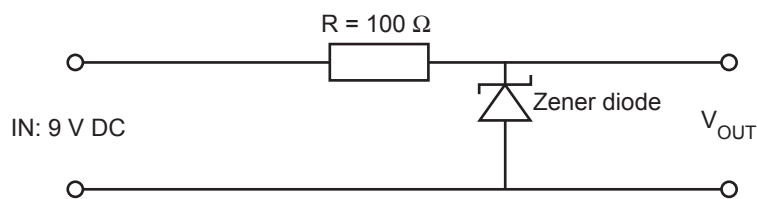

Figure 5

Question 7

What would be the value of V_{OUT} ?

2 marks

Question 8

What would be the voltage measured across the resistor R?

2 marks

Question 9

With no load connected across V_{OUT} , what would be the current through the Zener diode?

mA

2 marks

In order to provide a 12 V DC power supply for use by the physics laboratory class, the teacher builds and installs a full-wave bridge rectifier with a suitable smoothing capacitor. The teacher tests the power supply, and measures the output to be 12 V DC. However, when the whole class is using it, the voltage at each student's desk is only 11 V DC.

Question 10

In the space below explain why the voltage has dropped to 11 V DC.

2 marks

Question 11

In the space below, describe two changes to the power supply that would ensure that the voltage at each desk would be 12 V DC even when the whole class is using the power supply.

2 marks

An oscilloscope is set with the vertical scale on 2 V/cm, and the horizontal scale on 5 ms/cm. With no input signal, the trace is in the position shown in Figure 6.

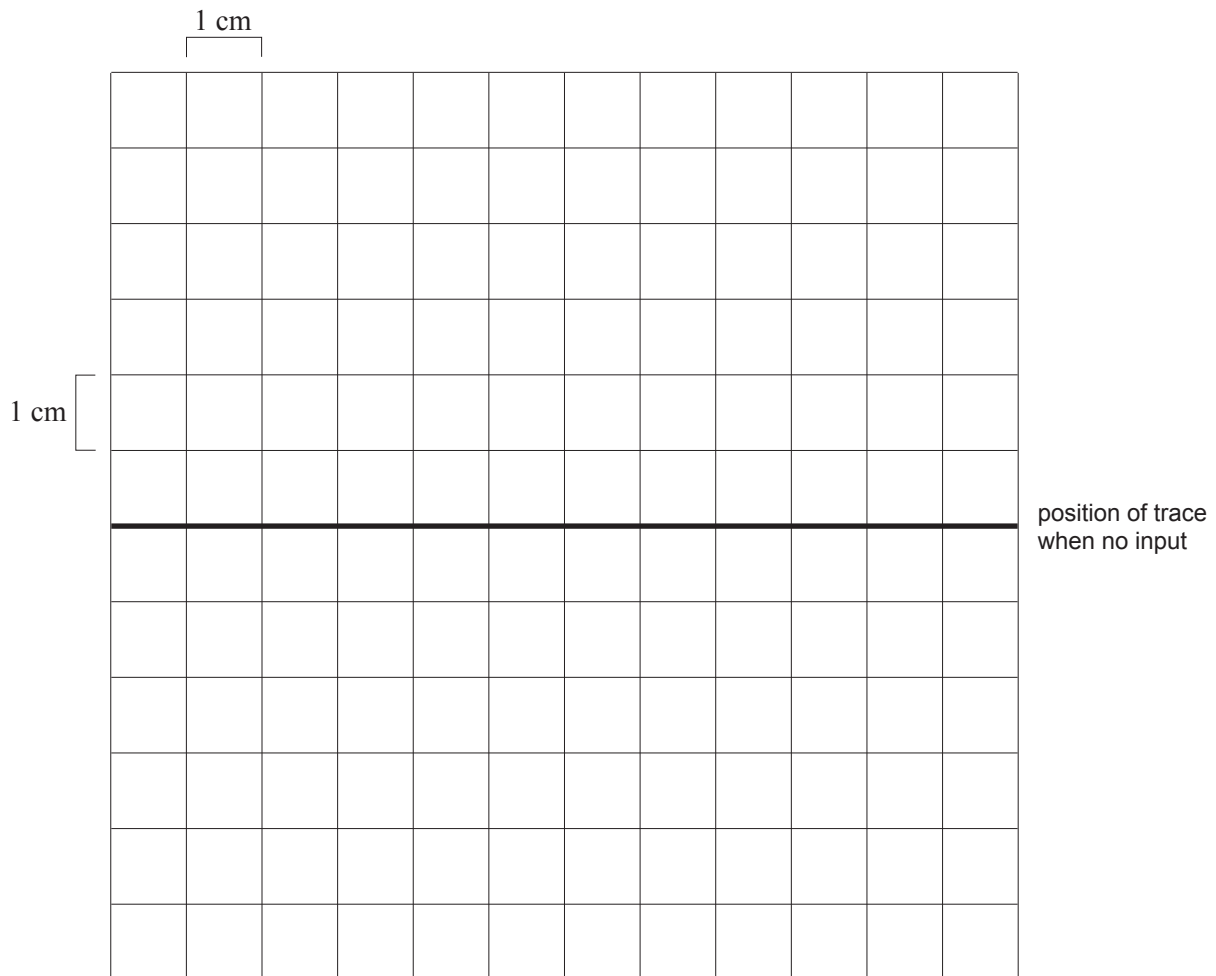

Figure 6

A $4.0 V_{\text{RMS}}$ sine-wave signal of frequency 50 Hz is connected to the oscilloscope.

Question 12

On the diagram of the oscilloscope screen shown in Figure 6, sketch the trace that would be observed.

2 marks

PHYSICS

Written examination 1

DATA SHEET

Directions to students

Detach this data sheet before commencing the examination.

This data sheet is provided for your reference.

1	velocity; acceleration	$v = \frac{\Delta x}{\Delta t}; \quad a = \frac{\Delta v}{\Delta t}$
2	equations for constant acceleration	$v = u + at$ $x = ut + \frac{1}{2}at^2$ $v^2 = u^2 + 2ax$ $x = \frac{1}{2}(v + u)t$
3	Newton's second law	$F = ma$
4	circular motion	$a = \frac{v^2}{r} = \frac{4\pi^2 r}{T^2}$
5	Hooke's law	$F = -kx$
6	elastic potential energy	$\frac{1}{2}kx^2$
7	gravitational potential energy near the surface of the Earth	mgh
8	kinetic energy	$\frac{1}{2}mv^2$
9	Newton's law of universal gravitation	$F = G \frac{M_1 M_2}{r^2}$
10	gravitational field	$g = G \frac{M}{r^2}$
11	stress	$\sigma = \frac{F}{A}$
12	strain	$\varepsilon = \frac{\Delta L}{L}$
13	Young's modulus	$E = \frac{\text{stress}}{\text{strain}}$
14	transformer action	$\frac{V_1}{V_2} = \frac{N_1}{N_2}$
15	AC voltage and current	$V_{\text{RMS}} = \frac{1}{2\sqrt{2}} V_{\text{p-p}} \quad I_{\text{RMS}} = \frac{1}{2\sqrt{2}} I_{\text{p-p}}$
16	voltage; power	$V = RI \quad P = VI$

17	resistors in series	$R_T = R_1 + R_2$
18	resistors in parallel	$\frac{1}{R_T} = \frac{1}{R_1} + \frac{1}{R_2}$
19	capacitors	time constant : $\tau = RC$
20	Lorentz factor	$\gamma = \frac{1}{\sqrt{1 - v^2/c^2}}$
21	time dilation	$t = t_0 \gamma$
22	length contraction	$L = L_0 / \gamma$
23	relativistic mass	$m = m_0 \gamma$
24	universal gravitational constant	$G = 6.67 \times 10^{-11} \text{ N m}^2 \text{ kg}^{-2}$
25	mass of Earth	$M_E = 5.98 \times 10^{24} \text{ kg}$
26	radius of Earth	$R_E = 6.37 \times 10^6 \text{ m}$
27	mass of the electron	$m_e = 9.1 \times 10^{-31} \text{ kg}$
28	charge on the electron	$q = -1.6 \times 10^{-19} \text{ C}$
29	speed of light	$c = 3.0 \times 10^8 \text{ m s}^{-1}$

Prefixes/Units

p = pico = 10^{-12}

n = nano = 10^{-9}

μ = micro = 10^{-6}

m = milli = 10^{-3}

k = kilo = 10^3

M = mega = 10^6

G = giga = 10^9

t = tonne = 10^3 kg

END OF DATA SHEET