



# Victorian Certificate of Education

## 2010

SUPERVISOR TO ATTACH PROCESSING LABEL HERE

### STUDENT NUMBER

Letter

Figures										
Words										

## PHYSICS

### Written examination 2

Wednesday 10 November 2010

Reading time: 11.45 am to 12.00 noon (15 minutes)

Writing time: 12.00 noon to 1.30 pm (1 hour 30 minutes)

### QUESTION AND ANSWER BOOK

#### Structure of book

<i>Section</i>	<i>Number of questions</i>	<i>Number of questions to be answered</i>	<i>Number of marks</i>
<b>A – Core – Areas of study</b>			
1. Electric power	20	20	40
2. Interactions of light and matter	11	11	26
<b>B – Detailed studies</b>			
1. Synchrotron and its applications <b>OR</b>	12	12	24
2. Photonics <b>OR</b>	12	12	24
3. Sound	12	12	24
			Total 90

- Students are permitted to bring into the examination room: pens, pencils, highlighters, erasers, sharpeners, rulers, up to two pages (one A4 sheet) of pre-written notes (typed or handwritten) and one scientific calculator.
- Students are NOT permitted to bring into the examination room: blank sheets of paper and/or white out liquid/tape.

#### Materials supplied

- Question and answer book of 51 pages. A formula sheet.
- Answer sheet for multiple-choice questions.

#### Instructions

- Write your **student number** in the space provided above on this page.
- Check that your **name** and **student number** as printed on your answer sheet for multiple-choice questions are correct, **and** sign your name in the space provided to verify this.
- All written responses must be in English.

#### At the end of the examination

- Place the answer sheet for multiple-choice questions inside the front cover of this book.

**Students are NOT permitted to bring mobile phones and/or any other unauthorised electronic devices into the examination room.**

**This page is blank**

**NO WRITING ALLOWED IN THIS AREA**

**SECTION A – Core****Instructions for Section A**

Answer **all** questions **for both** Areas of study in this section in the spaces provided. Write using black or blue pen.

Where an answer box has a unit printed in it, give your answer in that unit.

You should take the value of  $g$  to be  $10 \text{ m s}^{-2}$ .

Where answer boxes are provided write your final answer in the box.

In questions worth more than 1 mark appropriate working should be shown.

Unless otherwise indicated, diagrams are not to scale.

<b>Areas of study</b>	<b>Page</b>
Electric power .....	4
Interactions of light and matter .....	16

**NO WRITING ALLOWED IN THIS AREA**

## Area of study 1 – Electric power

The following information relates to Questions 1–5.

Figure 1 shows a solenoid and a battery.

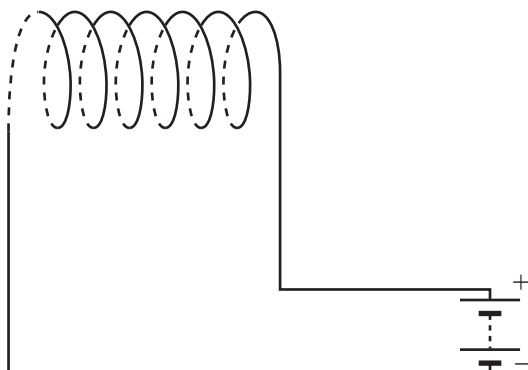

Figure 1

### Question 1

Draw **three** magnetic field lines, with arrows to show direction, to indicate the magnetic field produced both inside and outside the solenoid.

2 marks

The following information relates to Questions 2–5.

A rectangular loop of wire, PQRS, of sides  $PQ = 4.0$  cm and  $QR = 8.0$  cm, is placed inside the solenoid as shown in Figure 2.

The loop has 3 turns of wire. A current of 4.0 amps flows in the loop, in the direction indicated by the arrow.

The uniform magnetic field strength inside the solenoid is  $5.0 \times 10^{-2}$  T.

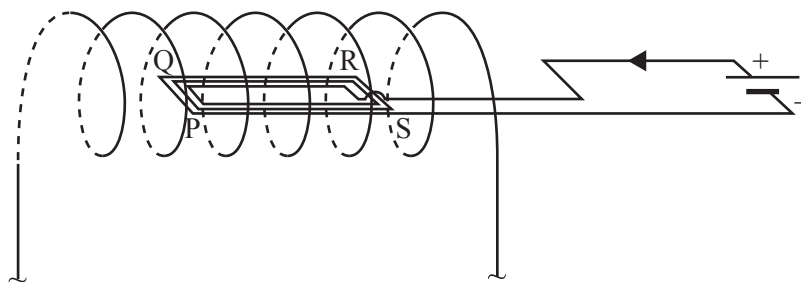

Figure 2

**Question 2**

What is the magnetic flux threading the loop? Explain your answer.

Wb
----

---

---

---

---

2 marks

**Question 3**

Draw an arrow on Figure 2 to indicate the direction of the force on the side PQ.

1 mark

**Question 4**

What is the magnitude of the force on the side PQ? Show your working.

N
---

2 marks

**Question 5**

What is the force (magnitude and direction) on the side QR? Explain your answer.

---

---

---

---

2 marks

NO WRITING ALLOWED IN THIS AREA

The following information relates to Questions 6 and 7.

Emily and Gerry have been studying generators and alternators. They have constructed the device shown in Figure 3. The rectangular coil, which is a single loop of area of  $9.0 \times 10^{-4} \text{ m}^2$ , is rotated in the direction shown, in a uniform magnetic field with a direction indicated by **B**.

The coil is completely contained in the magnetic field.

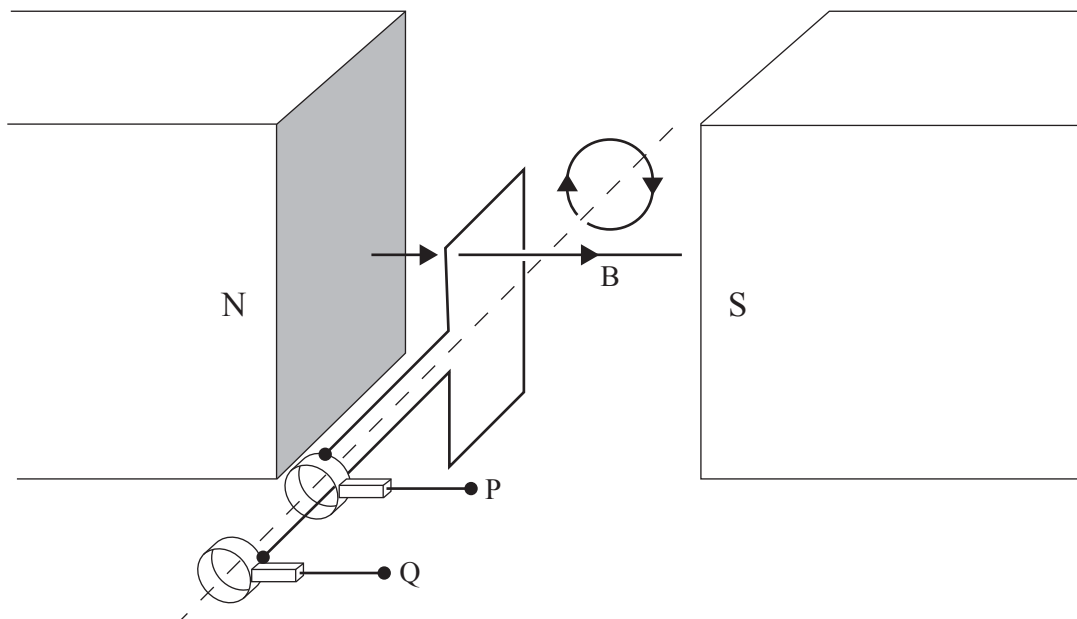

Figure 3

They tested the device by firstly connecting an oscilloscope between the terminals P and Q, and then rotating the coil at a constant rate, in the uniform field B, in the direction shown.

Figure 4 shows graphs of the magnetic flux through the coil and of the voltage measured between the terminals.

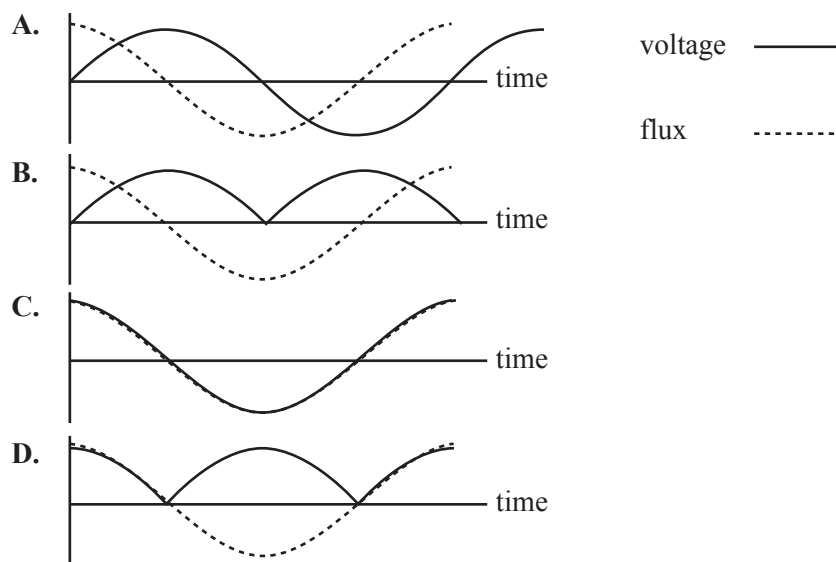

Figure 4

NO WRITING ALLOWED IN THIS AREA

**Question 6**

Which one of the graphs in Figure 4 best represents the voltage observed on the oscilloscope?



2 marks

**Question 7**

Explain the difference in function between a split-ring commutator and slip rings. Describe the situations in which a split-ring commutator and slip rings are used.

---

---

---

---

---

---

---

---

---

---

---

---

---

---

---

---

---

---

---

---

---

---

---

3 marks

**NO WRITING ALLOWED IN THIS AREA**

The following information relates to Questions 8–11.

Figure 5 shows an experiment where the voltage induced in a coil by a time-dependent magnetic field is measured. The voltmeter measures the voltage induced in the coil as a function of time. The coil has 120 turns.

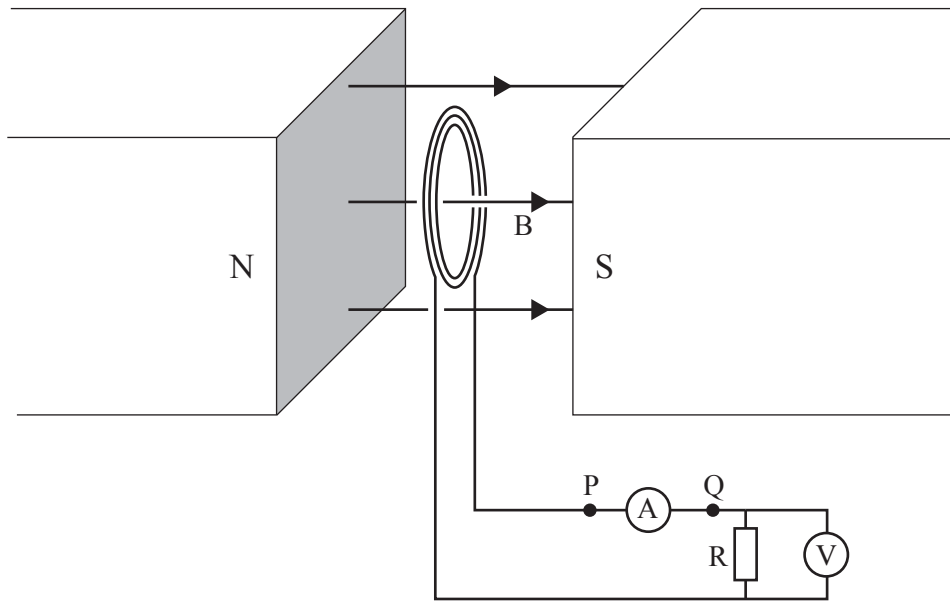

Figure 5

The magnetic field varies with time as shown in Figure 6.

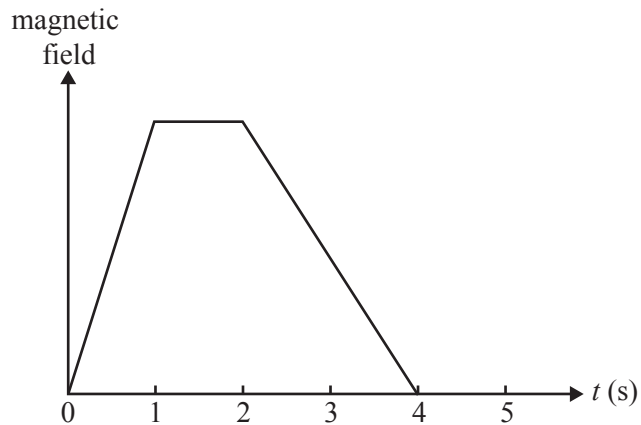

Figure 6

NO WRITING ALLOWED IN THIS AREA



**Question 8**

Sketch a graph of voltage against time as measured by the voltmeter.

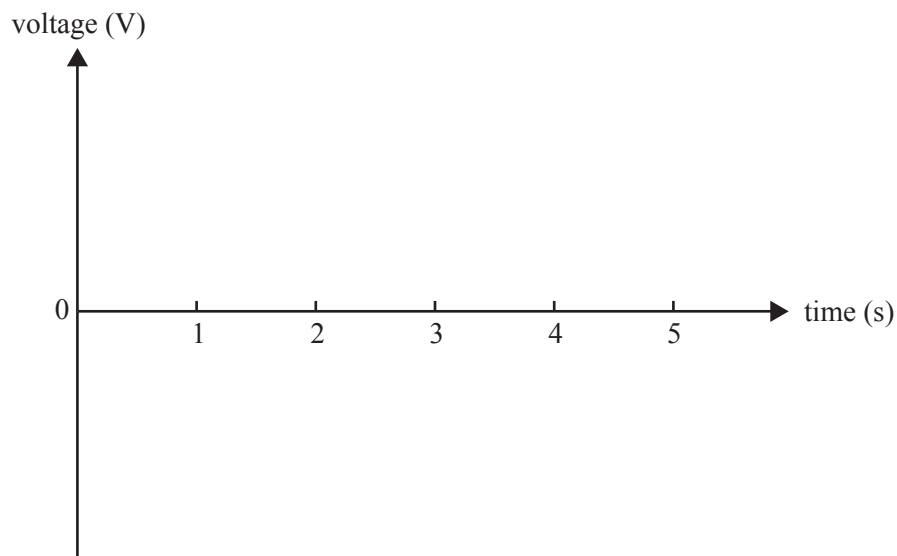

2 marks

**Question 9**

Identify the physical law you used for constructing your graph.

1 mark

At another time, the magnetic flux through the 120 turns coil is a constant  $3.0 \times 10^{-4}$  Wb.

**Question 10**

The magnetic field is now reduced to zero over a period of 0.012 s.

What is the average EMF induced in the coil during that 0.012 s interval? Show your working.

V

2 marks

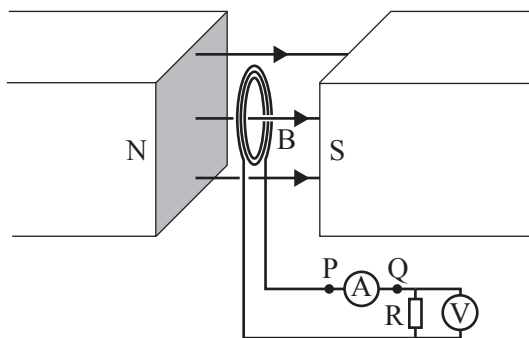

Figure 5 (repeated)

**Question 11**

As the field is being reduced, in what direction (P → Q or Q → P) will the current flow through the ammeter A in Figure 5 above? Explain your answer.

Direction

---

---

---

---

---

---

2 marks

NO WRITING ALLOWED IN THIS AREA

The following information relates to Questions 12 and 13.

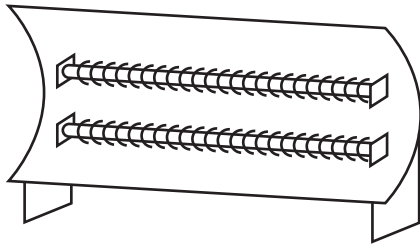

Figure 7

Hilary has bought a new electric heater, as shown in Figure 7, that operates on an AC voltage of  $240 \text{ V}_{\text{RMS}}$ . It has two identical heating elements, each with a constant resistance of  $48 \Omega$ . The elements can be connected in three different ways to provide three heating power settings of

- 600 W
- 1200 W
- 2400 W.

**Question 12**

When the heater is used with **only one element connected**, what is the power output? Show your working.

W
---

2 marks

**Question 13**

Complete the circuit below to show the connections when the heater is set to provide a heating power of 600 W.

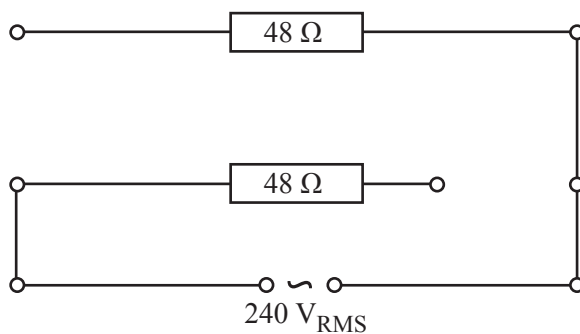

2 marks

NO WRITING ALLOWED IN THIS AREA

The following information relates to Questions 14–20.

Students are using a model of a transmission line to study power and voltage loss in transmission lines.

The students' 'transmission lines' consist of two wires, **each** of constant resistance  $2.0 \Omega$ . As a load they use a  $4.0 \text{ W}$  globe which operates at  $4.0 \text{ W}$  when there are  $2.0 \text{ V}$  across it.

The experimental arrangement is shown in Figure 8.

The connecting wires from the power supply to the transmission lines and from the transmission lines to the globe have negligible resistance.

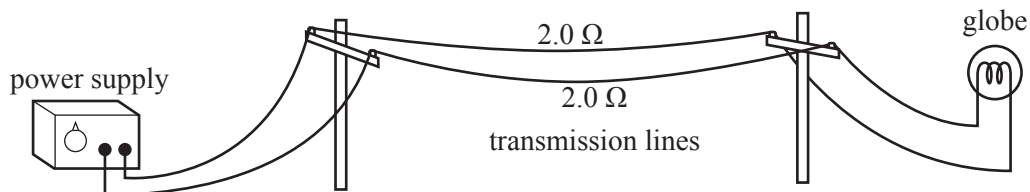

Figure 8

#### Question 14

Initially the students use the power supply set on a voltage of  $2.0 \text{ V DC}$ .

They find that the globe does not glow as brightly as they expected. Explain why.

---



---



---



---



---

2 marks

NO WRITING ALLOWED IN THIS AREA

**Question 15**

The voltage setting of the power supply is then set so that the globe operates at 4.0 W as designed. Calculate the required voltage setting of the power supply. Show your working.

3 marks

**Question 16**

When the globe is operating at 4.0 W as designed, what is the power loss in the transmission lines? Show your working.

2 marks

One of the students, Catherine, says that in the real situation which they are attempting to model, this fractional power loss would be unacceptable. She observes that AC rather than DC is often used for long-distance electric power transmission systems.

**Question 17**

Explain why AC is often used for long-distance electric power transmission.

---

---

---

---

2 marks

NO WRITING ALLOWED IN THIS AREA

To model this AC transmission system, the students modify their experiment as shown in Figure 9 below.

They set the output of the power supply to  $20.8 \text{ V}_{\text{RMS}}$  AC. They use a 10:1 step-down transformer at the other end. The output of the transformer is connected to the globe.

The globe is operating at  $2.0 \text{ V}$  and  $4.0 \text{ W}$ .

This is shown in Figure 9. Consider the transformer as ideal.

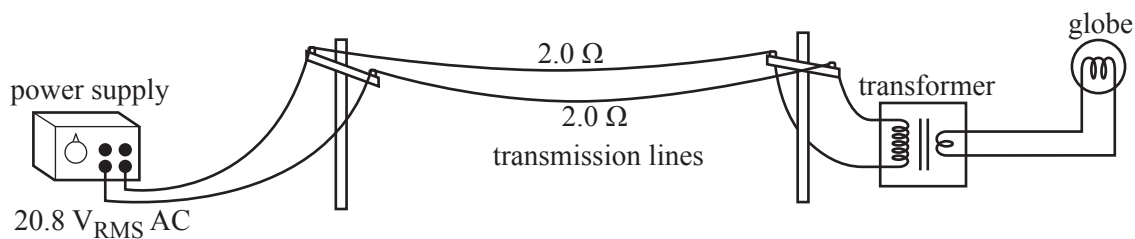

Figure 9

**Question 18**

Before connecting the circuit, the students test the power supply by connecting it to an oscilloscope as shown in Figure 10.



Figure 10

What signal will they observe on the oscilloscope?

- A.  $20.8 \text{ V}$  peak
- B.  $20.8 \text{ V}$  peak to peak
- C.  $29.4 \text{ V}$  peak to peak
- D.  $58.8 \text{ V}$  peak to peak

2 marks

NO WRITING ALLOWED IN THIS AREA

**Question 19**

The input coil of the 10:1 step-down transformer has 1460 turns.

How many turns does the secondary coil have?

1 mark

**Question 20**

With the experiment set up as in Figure 9, what is the power loss in the transmission lines? Show your working.

3 marks

NO WRITING ALLOWED IN THIS AREA

---

**END OF AREA OF STUDY 1**  
**SECTION A – continued**  
**TURN OVER**

**Area of study 2 – Interactions of light and matter****Question 1**

Over the last few centuries, scientists have proposed two conflicting models to explain the nature of light.

- the wave model
- the particle model

Name a historical experiment that supports the wave model rather than the particle model. Explain how the experiment supports the wave model rather than the particle model.

---

---

---

---

---

---

---

---

---

---

---

3 marks

**NO WRITING ALLOWED IN THIS AREA**



The photoelectric effect experiment supports the particle model of light rather than the wave model of light.

The following are observed in a photoelectric effect experiment.

**Observation 1:** The number of emitted electrons (the photocurrent) depends on the intensity of the incident light.

**Observation 2:** The energy of emitted electrons depends only on the frequency of the incident light and is independent of the intensity.

**Observation 3:** The energy of the emitted electrons depends on the metal surface involved.

The particle model can account for all the above three observations.

The wave model can explain two of these observations but not a third.

### Question 2

Select the observation that the wave model **cannot** explain.

Explain how the particle model satisfactorily explains this observation.

Observation number

3 marks

The following information relates to Questions 3 and 4.

Two students are studying interference of light.

They use a laser of wavelength 580 nm.

**Question 3**

What is the energy (in eV) of one photon of the light from the laser? Show your working.

eV
----

2 marks

The students set up the laser, two slits,  $S_1$  and  $S_2$ , and a screen on which an interference pattern is observed, as shown in Figure 1a.

The pattern they observe on the screen is also shown in Figure 1b.

C indicates the centre of the pattern.

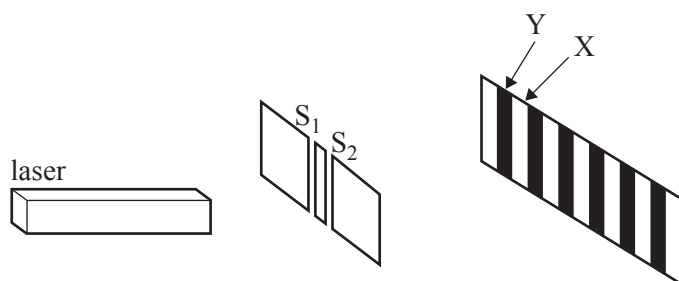

**Figure 1a**

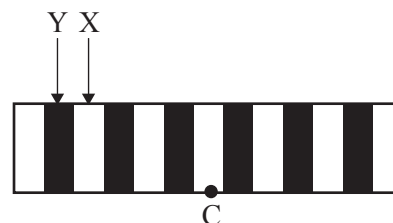

**Figure 1b**

X is at the centre of a bright band. Y is at the centre of the dark band next to X and further away from the centre of the pattern.

The path difference  $S_2X - S_1X$  is 1160 nm.

**Question 4**

What is the path difference  $S_2Y - S_1Y$ ? Show your working.

	nm
--	----

2 marks

---

NO WRITING ALLOWED IN THIS AREA

The following information relates to Questions 5 and 6.

Students set up the following apparatus as shown in Figure 2 to study the photoelectric effect.

They have a number of photocells with different metal plates in them.

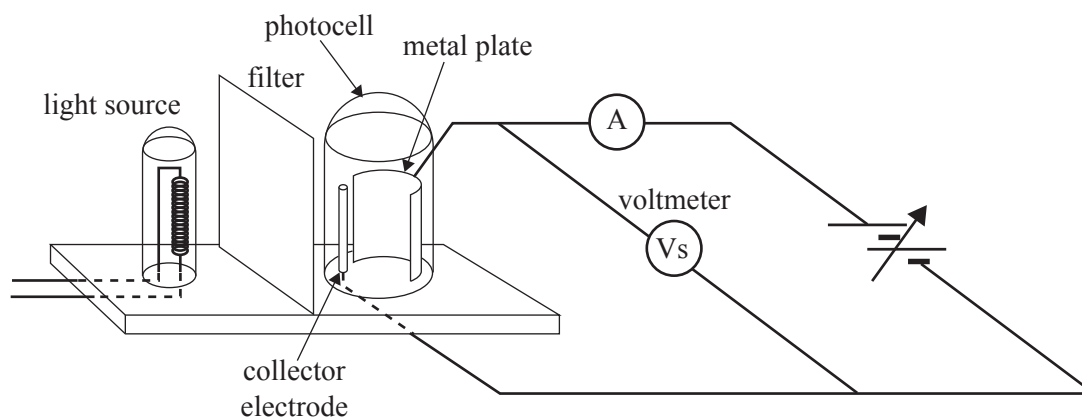

Figure 2

With a selenium plate in place, and using their data, the students draw the graph of maximum kinetic energy of photoelectrons versus frequency of light incident on the selenium plate. This is shown in Figure 3.

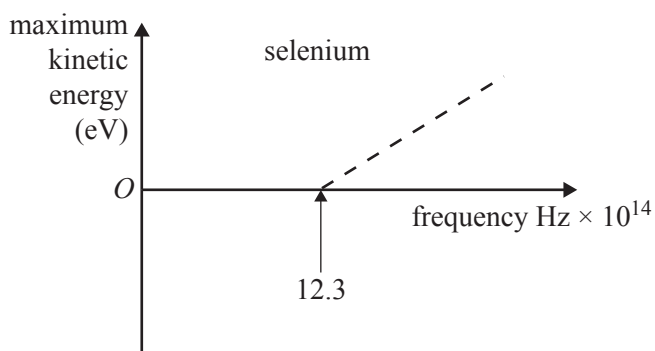
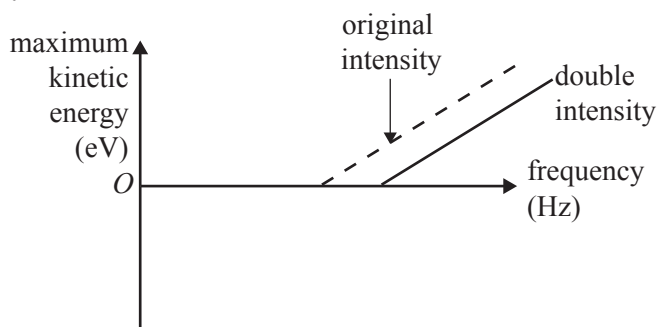
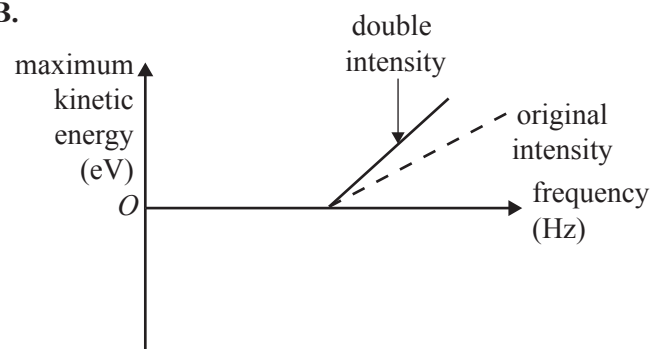
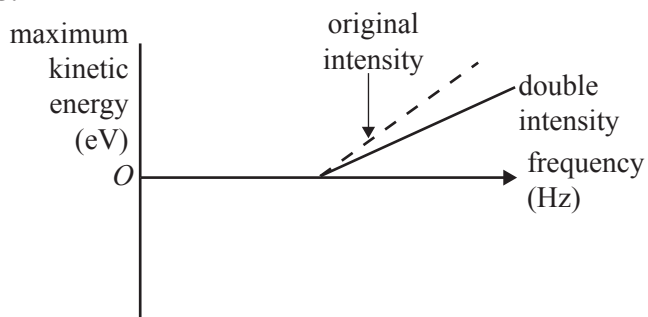
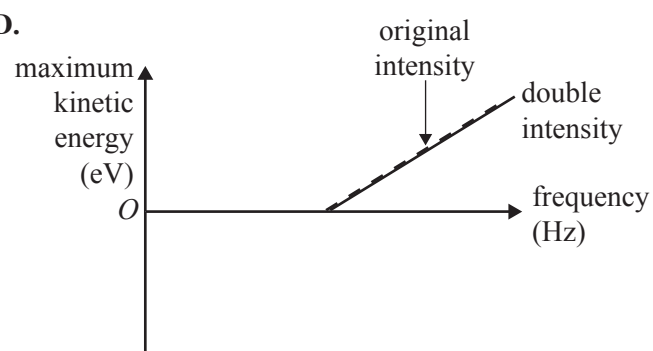

Figure 3

**Question 5**

The students double the intensity of the light source and repeat the experiment.

Which one of the following graphs will now show their results?

**A.****B.****C.****D.**

2 marks

The students now use a photocell with a magnesium plate.  
The work function of magnesium (3.7 eV) metal is less than that of selenium (5.1 eV).

**The dotted line on each graph shows the original graph for selenium.**

**Question 6**

Which one of the following graphs will now show their results? Explain your answer.

**A.**

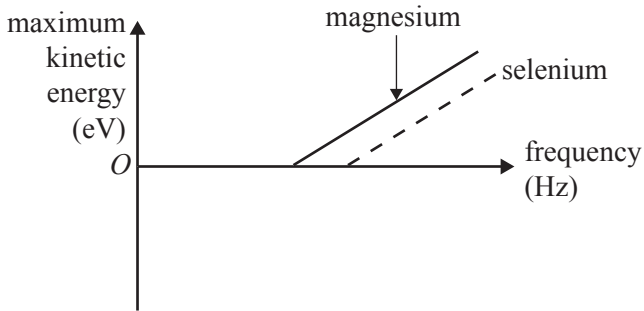

**B.**

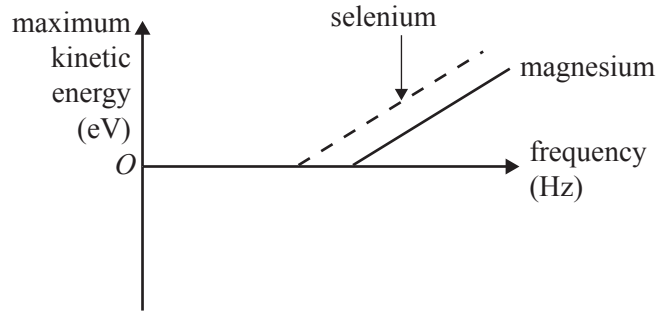

**C.**

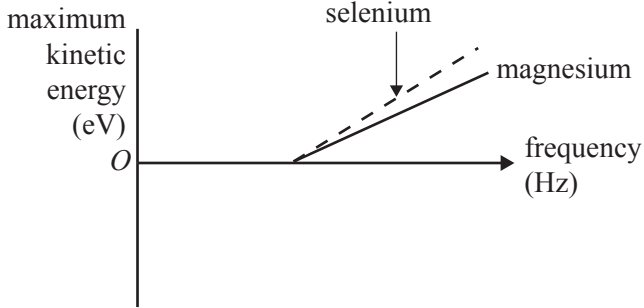

**D.**

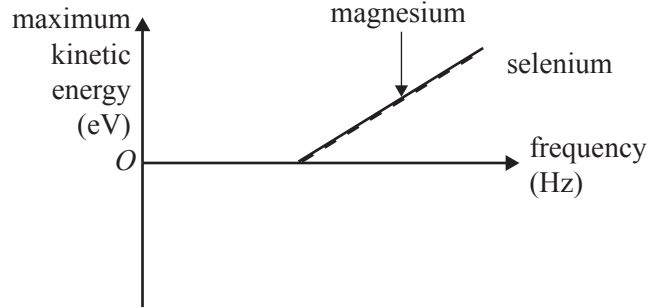

---

---

---

---

---

---

---

---

---

---

3 marks

NO WRITING ALLOWED IN THIS AREA

**NO WRITING ALLOWED IN THIS AREA**

**CONTINUES OVER PAGE**

**SECTION A – Area of study 2 – continued**  
**TURN OVER**

The following information relates to Questions 7–10.

Students study diffraction of electrons by a crystal lattice.

The apparatus is shown in Figure 4a.

In this apparatus electrons of mass  $9.1 \times 10^{-31}$  kg are accelerated to a speed of  $1.5 \times 10^7$  m s<sup>-1</sup>.

The electrons pass through the crystal, and the diffraction pattern is observed on a fluorescent screen. The pattern the students observe is shown in Figure 4b.

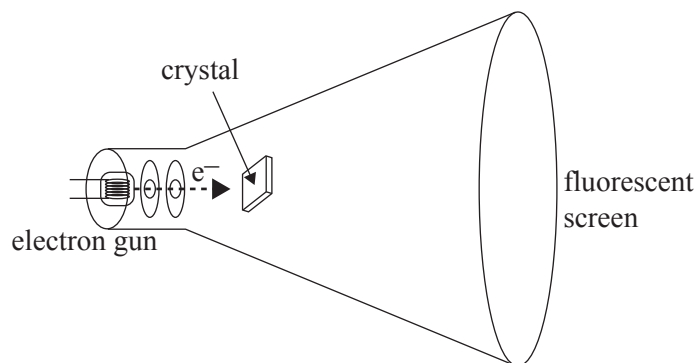

Figure 4a

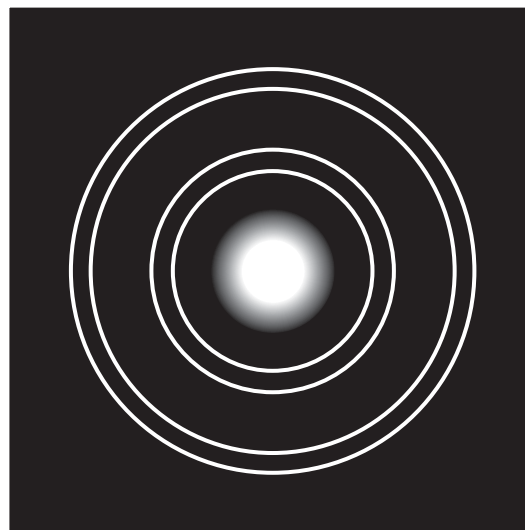

Figure 4b

**Question 7**

Calculate the de Broglie wavelength of the electrons. Show your working.

 nm

2 marks

NO WRITING ALLOWED IN THIS AREA



**Question 8**

The students now increase the accelerating voltage and hence the speed of the electrons.

Which one of the options below now best shows the pattern they will observe on the screen?

Explain your answer.

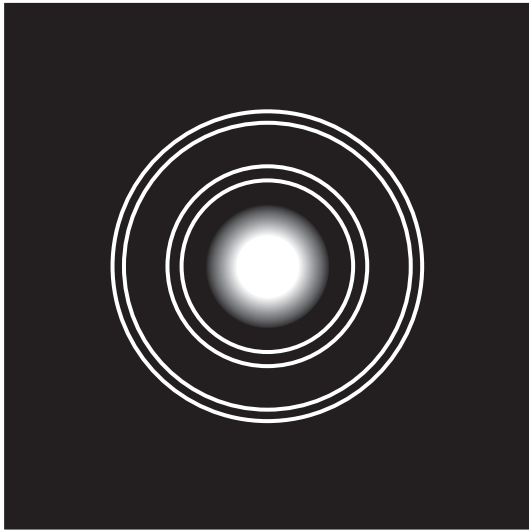

option A

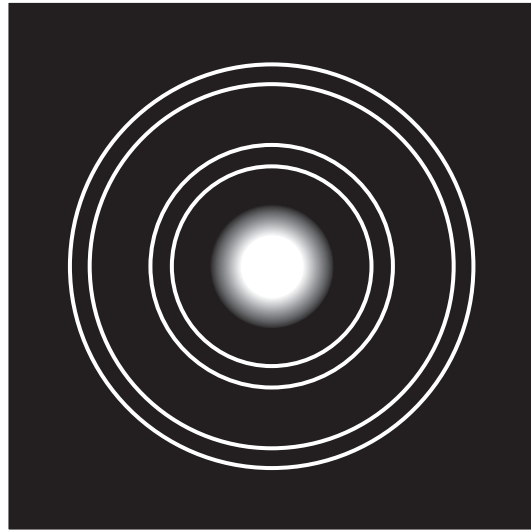

option B (identical to original pattern)

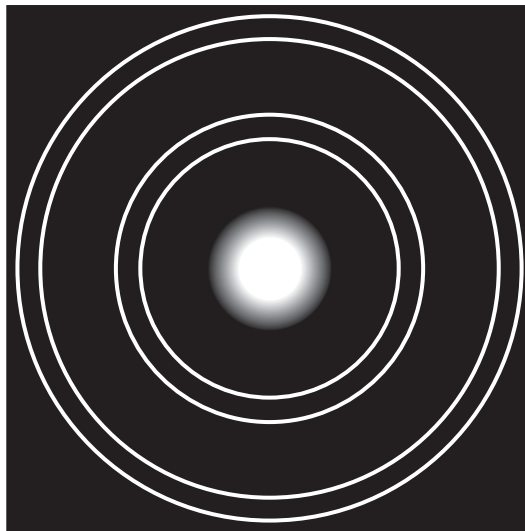

option C



---



---



---



---

2 marks

NO WRITING ALLOWED IN THIS AREA

Figure 5a shows the diffraction with electrons of 600 eV. The students now replace the electron gun with an X-ray source. Then they observe the pattern shown in Figure 5b below.

Figures 5a and 5b are drawn to the same scale.



Figure 5a

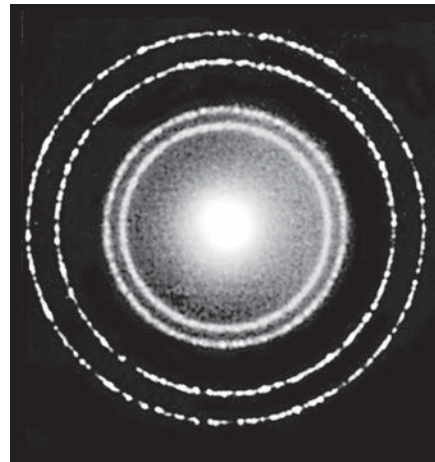

Figure 5b

**Question 9**

Explain why the electrons and the X-rays produce a very similar pattern.

---

---

---

---

2 marks

NO WRITING ALLOWED IN THIS AREA

**Question 10**

Estimate the energy, in eV, of a photon of these X-rays. Show your working.

	eV
--	----

3 marks



NO WRITING ALLOWED IN THIS AREA

Figure 6 shows the energy level diagram for the hydrogen atom.

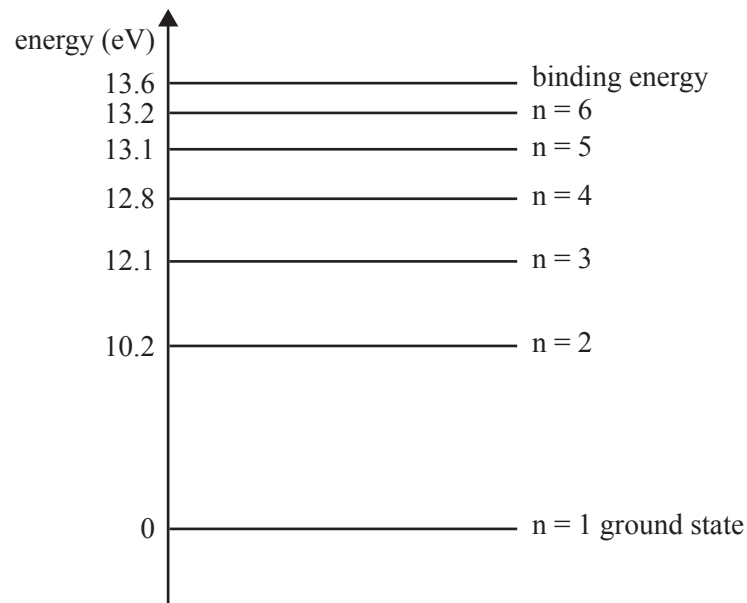

Figure 6

**Question 11**

A photon of wavelength 478 nm is emitted from an excited hydrogen atom.

The emerging photon is caused by a transition between two energy states.

Draw an arrow on Figure 6 that shows this transition from the initial to the final energy state.

2 marks

---

NO WRITING ALLOWED IN THIS AREA

END OF SECTION A

**SECTION B – Detailed studies****Instructions for Section B**

Select **one** Detailed study.

Answer **all** questions from the Detailed study, in pencil, on the answer sheet provided for multiple-choice questions.

Write the name of your chosen Detailed study on the multiple-choice answer sheet **and** shade the matching box.

Choose the response that is **correct** for the question.

A correct answer scores 2, an incorrect answer scores 0.

Marks will **not** be deducted for incorrect answers.

No marks will be given if more than one answer is completed for any question.

You should take the value of  $g$  to be  $10 \text{ m s}^{-2}$ .

Unless indicated, diagrams are not to scale.

<b>Detailed study</b>	<b>Page</b>
Synchrotron and its applications.....	30
Photonics.....	38
Sound .....	44

NO WRITING ALLOWED IN THIS AREA

## Detailed study 1 – Synchrotron and its applications

The following information relates to Questions 1–4.

An electron gun is used to inject electrons into the linac of a synchrotron.

Figure 1 shows a schematic diagram of the electron gun.

The mass of the electron is  $9.1 \times 10^{-31}$  kg, and the charge on the electron is  $1.6 \times 10^{-19}$  C.

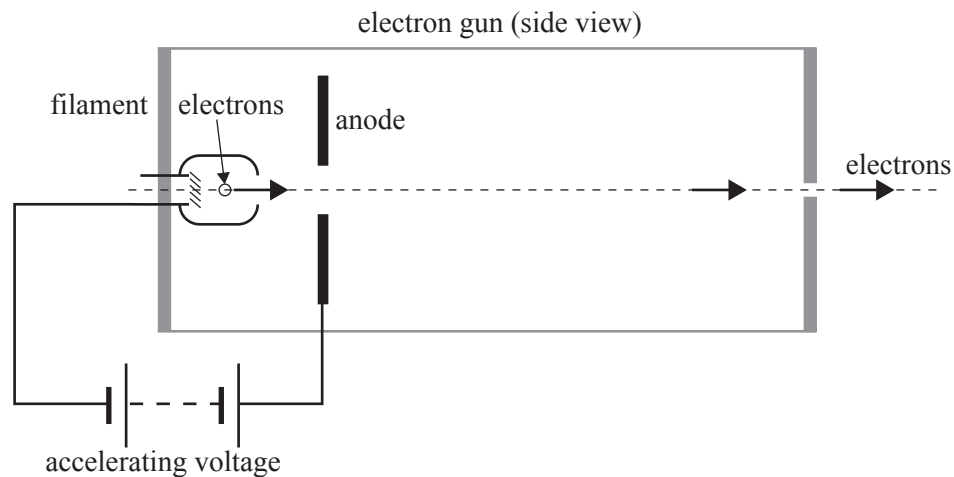

Figure 1

The electron gun is tested by first operating it at a low voltage.

Using this voltage the acceleration of the electrons is  $1.8 \times 10^{15}$  m s<sup>-2</sup>.

### Question 1

What is the magnitude of the electric field acting on the electrons?

- A. 1 kV m<sup>-1</sup>
- B. 10 kV m<sup>-1</sup>
- C. 100 kV m<sup>-1</sup>
- D. 1000 kV m<sup>-1</sup>

The accelerating voltage of the electron gun is now increased to its maximum value.

The electrons now reach a speed of  $4.6 \times 10^7$  m s<sup>-1</sup>.

### Question 2

Which of the following best gives the accelerating voltage now?

- A. 600 V
- B. 2600 V
- C. 6000 V
- D. 260000 V

An electron with a speed of  $4.6 \times 10^7 \text{ m s}^{-1}$  then enters a uniform magnetic field and moves in a circular path. The radius of the path is 0.40 m. This is shown in Figure 2.

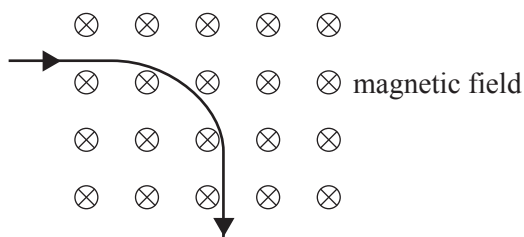

**Figure 2**

**Question 3**

What is the magnitude of the magnetic field required to achieve this path?

- A.  $4.2 \times 10^{-3} \text{ T}$
- B.  $6.5 \times 10^{-4} \text{ T}$
- C.  $1.5 \times 10^3 \text{ T}$
- D.  $3.0 \times 10^4 \text{ T}$

The magnetic field is now adjusted to  $5.0 \times 10^{-4} \text{ T}$ .

**Question 4**

Which of the following now best gives the magnetic force on the electron?

- A.  $4.80 \times 10^{-17} \text{ N}$
- B.  $3.68 \times 10^{-15} \text{ N}$
- C.  $2.40 \times 10^{-14} \text{ N}$
- D.  $3.68 \times 10^{-7} \text{ N}$

*The following information relates to Questions 5–6.*

Figure 3 shows a schematic plan of the Australian Synchrotron.

The Australian Synchrotron has four main components: beamline, booster ring, linac and storage ring.

The arrows **P**, **Q**, **R**, **S** indicate these components (not in order).

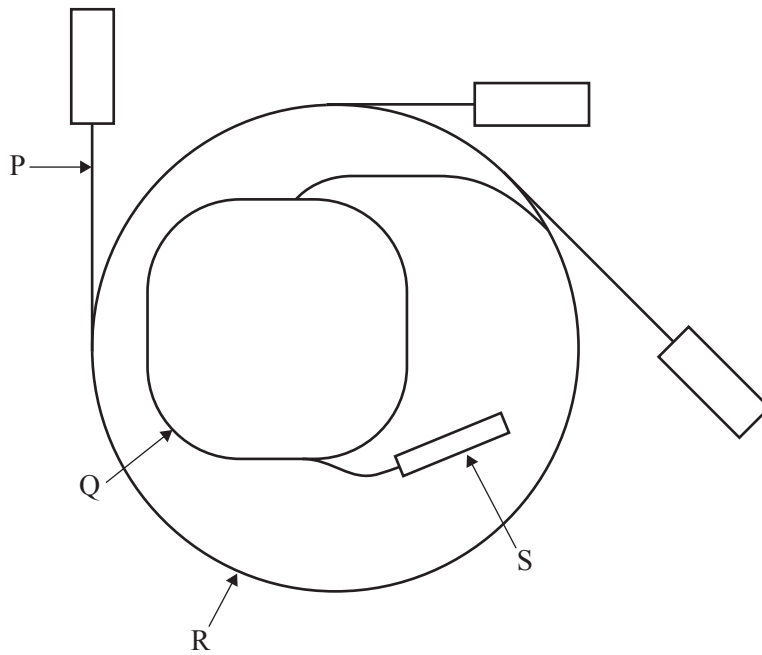

**Figure 3**

**NO WRITING ALLOWED IN THIS AREA**



**Question 5**

Which option below best indicates to which of the components the arrows **P, Q, R, S** refer?

	<b>P</b>	<b>Q</b>	<b>R</b>	<b>S</b>
<b>A.</b>	linac	booster ring	storage ring	beamline
<b>B.</b>	linac	storage ring	booster ring	beamline
<b>C.</b>	beamline	booster ring	storage ring	linac
<b>D.</b>	beamline	storage ring	booster ring	linac

**Question 6**

Which option below best describes a key function of each component?

	<b>Beamline</b>	<b>Booster ring</b>	<b>Linac</b>	<b>Storage ring</b>
<b>A.</b>	photons move through	electrons are accelerated to 0.8 c	photons are produced	electrons are accelerated to 0.9999 c
<b>B.</b>	photons move through	electrons are accelerated to 0.9999 c	electrons are accelerated to 0.8 c	photons are produced
<b>C.</b>	photons are produced	electrons are accelerated to 0.9999 c	electrons are accelerated to 0.8 c	electrons are accelerated to 0.9999 c
<b>D.</b>	electrons are accelerated to 0.8 c	electrons are accelerated to 0.9999 c	photons are produced	photons move through

The following information relates to Questions 7 and 8.

Synchrotron radiation consists of a range of wavelengths. Using Bragg scattering, a crystal of silicon can be used to select a specific wavelength for use in an experiment. Bragg's law gives the angles at which sharp peaks in the X-ray intensity are produced.

Figure 4a shows the experimental arrangement, and Figure 4b shows a schematic diagram of a silicon crystal with a crystal-plane separation of 0.314 nm.

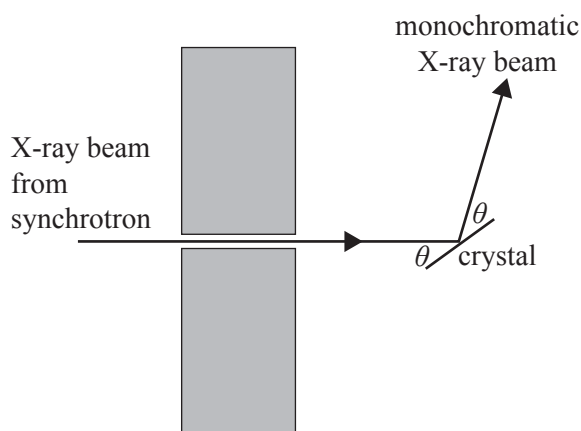

Figure 4a

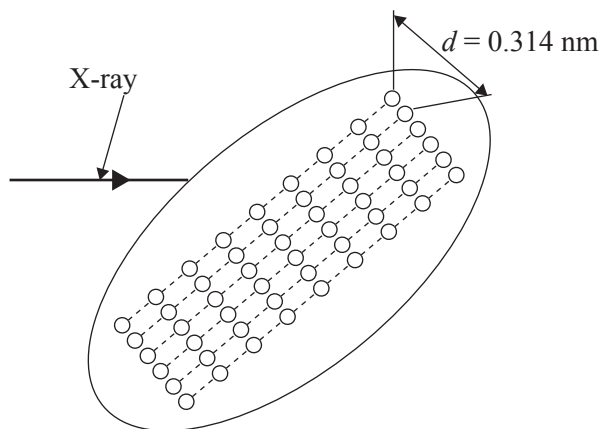

Figure 4b

### Question 7

To select the wavelength of the X-rays that are diffracted, the angle  $\theta$  is varied. Consider only first order scattering ( $n = 1$ ) from the planes shown in Figure 4b.

What will be the wavelength of X-rays that are diffracted at an angle of  $15^\circ$ ?

- A. 0.163 nm
- B. 0.314 nm
- C. 0.408 nm
- D. 0.607 nm

### Question 8

In another experiment, the same crystal is irradiated with a monochromatic beam of X-rays of wavelength 0.200 nm. The angle of the incident beam on the crystal is varied from  $0-90^\circ$ .

Consider **only** the peaks caused by scattering from the planes shown in Figure 4b (0.314 nm spacing).

How many peaks will be observed?

- A. 1
- B. 2
- C. 3
- D. 4

**Question 9**

In an experiment at the Australian Synchrotron, X-rays from a beamline are directed into a material being tested. The X-rays are scattered by collision with valence electrons, and are observed coming out at many angles, with the same wavelength as the incident photons.

This is an example of

- A. Thomson scattering because the energy of the X-rays is unchanged.
  - B. Thomson scattering because the energy of the X-rays has decreased due to losses in collisions.
  - C. Compton scattering because the energy of the X-rays is unchanged.
  - D. Compton scattering because the energy of the X-rays has decreased due to losses in collisions.
- 

NO WRITING ALLOWED IN THIS AREA

The following information relates to Questions 10 and 11.

Undulators are insertion devices for synchrotrons. They consist of two rows of magnets with alternating north and south poles. This is shown in Figure 5.

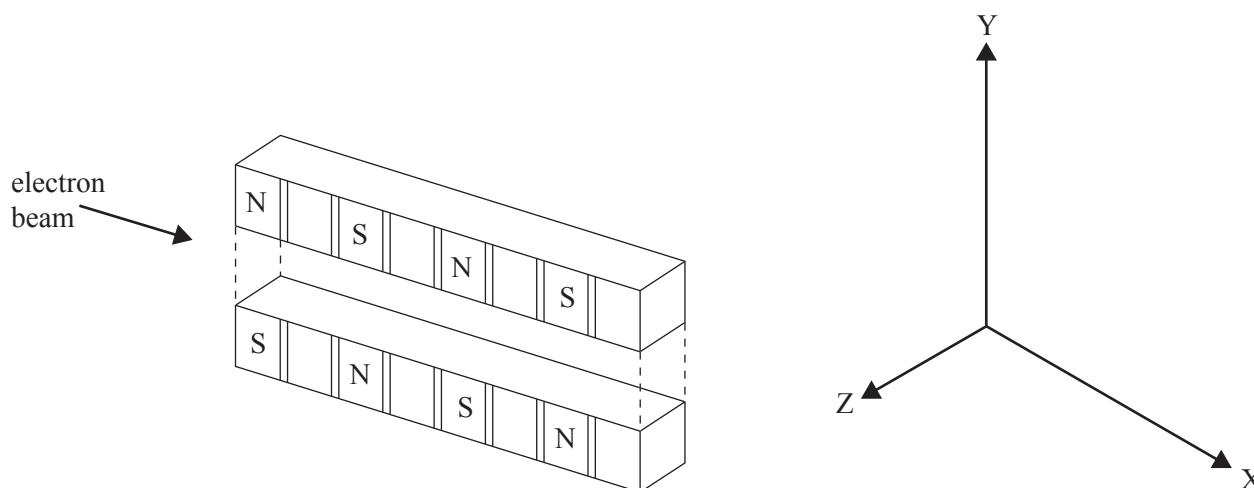

Figure 5

A beam of electrons enters the undulator from the left.

**Question 10**

Which statement best describes the path of the electrons?

- A. The electrons continue to move in the **X** direction with a side-to-side movement in the **Y** direction.
- B. The electrons continue to move in the **X** direction with a side-to-side movement in the **Z** direction.
- C. The electrons move in a spiral around the **X** direction.
- D. The electrons accelerate in the **X** direction.

**Question 11**

Where are undulators inserted in the Australian Synchrotron?

- A. linac
- B. beamline
- C. booster ring
- D. storage ring

NO WRITING ALLOWED IN THIS AREA

**Question 12**

Synchrotron radiation is produced when an electron

- A. travels very close to the speed of light.
  - B. collides with other electrons.
  - C. collides with air molecules.
  - D. changes direction.
- 

**NO WRITING ALLOWED IN THIS AREA**

**END OF DETAILED STUDY 1**  
**SECTION B – continued**  
**TURN OVER**

**Detailed study 2 – Photonics****Question 1**

Which one of the following contains only sources that produce predominantly incoherent light?

- A. incandescent globe, fluorescent tube, laser
- B. laser, fluorescent tube, sun
- C. sun, candle, incandescent globe
- D. sun, candle, laser

---

*The following information relates to Questions 2–4.*

The characteristics of a red light-emitting diode (LED) are shown in Figure 1 below.

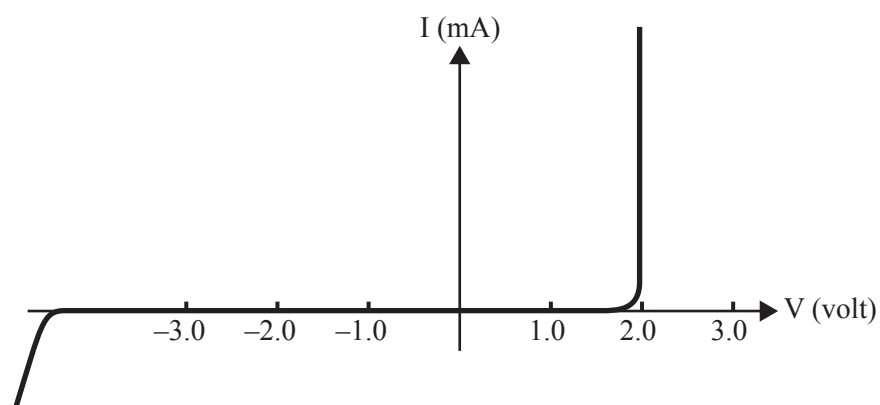

**Figure 1**

**Question 2**

Which of the following best gives the average wavelength of the light from this LED?

- A.  $9.94 \times 10^{-17}$  nm
- B. 62 nm
- C. 621 nm
- D. 994 nm

NO WRITING ALLOWED IN THIS AREA

A student sets up the following circuit to test this LED, as shown in Figure 2 below. The (ideal) battery has a voltage of 12 V and the resistor has a resistance of  $400\ \Omega$ .

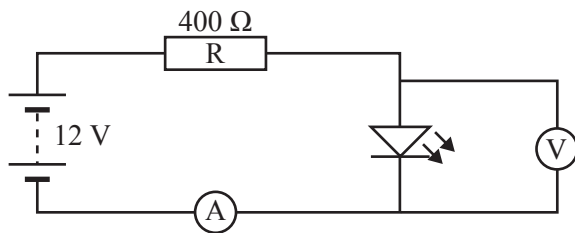

Figure 2

**Question 3**

Which of the following best gives the current through the ammeter?

- A. 5 mA
- B. 25 mA
- C. 30 mA
- D. 60 mA

**Question 4**

The red LED is replaced by a blue LED, using the same circuit.

Which of the following statements best describes the effect on the circuit?

- A. The blue LED emits light, and the current through it is greater than the current through the red LED.
- B. The blue LED emits light, and the current through it is the same as the current through the red LED.
- C. The blue LED emits light, and the current through it is less than the current through the red LED.
- D. The blue LED does not emit light, and the current through it is less than the current through the red LED.

The following information relates to Questions 5 and 6.

Figure 3 shows a step-index fibre-optic waveguide.

The outer cladding has a refractive index of 1.38, and the inner core has a refractive index of 1.44.

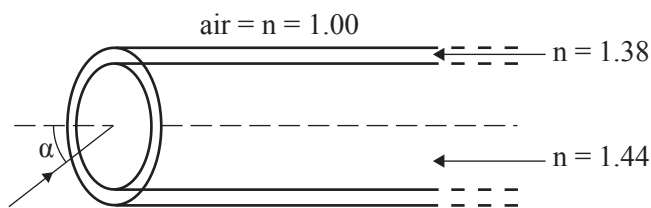

Figure 3

**Question 5**

Which of the following best gives the value of the critical angle for total internal reflection between the core and cladding?

- A.  $17^\circ$
- B.  $44^\circ$
- C.  $46^\circ$
- D.  $73^\circ$

**Question 6**

Which of the following best gives the limiting acceptance angle,  $\alpha$ , for the waveguide to operate correctly?

- A.  $15^\circ$
- B.  $24^\circ$
- C.  $44^\circ$
- D.  $66^\circ$

The following information relates to Questions 7 and 8.

Students are using a length of **flexible** plastic rod to investigate transmission of laser light through a fibre-optic waveguide. The plastic material has a refractive index of 1.20. The refractive index of air is 1.00. The situation is shown in Figure 4a.

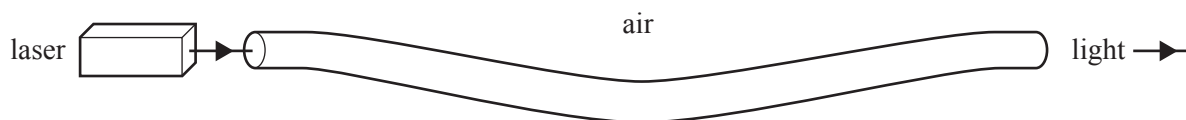
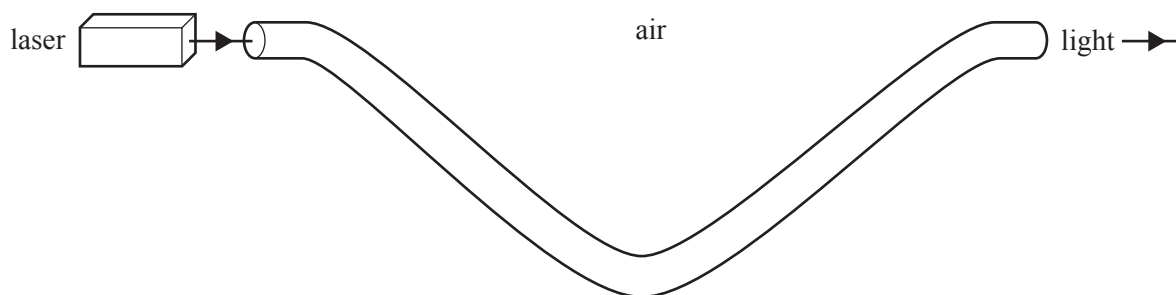

Figure 4a



**Question 7**

The students bend the rod more as shown in Figure 4b. They find that the intensity of light emerging from the rod decreases significantly.

**Figure 4b**

Which of the following statements is the most likely explanation for this?

- A. material dispersion
- B. The angle of incidence of the light ray on the side of the rod at some point has now become less than the critical angle for plastic to air.
- C. The angle of incidence of the light ray on the side of the rod at some point has now become greater than the critical angle for plastic to air.
- D. modal dispersion

**Question 8**

The bending of the plastic rod is reduced until the intensity of the light emerging from the rod increases significantly, as originally shown in Figure 4a.

The students now immerse the plastic rod in water, as shown in Figure 4c below. This action results in the intensity of the light emerging from the rod once again decreasing significantly.

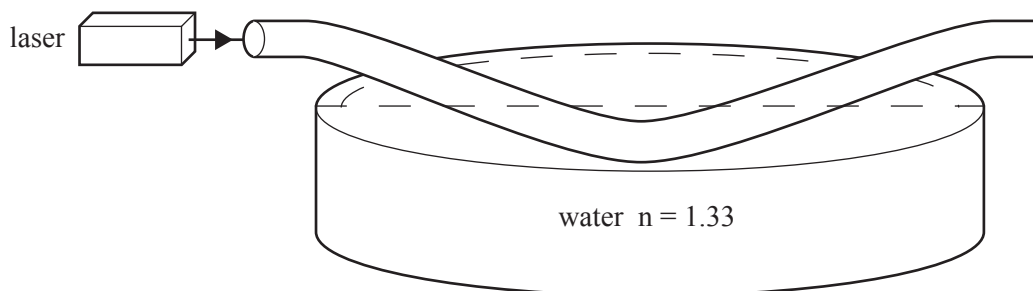
**Figure 4c**

The refractive index of water is 1.33.

Which of the following statements is the most likely explanation for this?

- A. The critical angle for total internal reflection has increased.
- B. Modal dispersion has reduced the light intensity reaching the end of the rod.
- C. Total internal reflection cannot now occur.
- D. Material dispersion has reduced the light intensity reaching the end of the rod.

The following information relates to Questions 9 and 10.

The graph in Figure 5 shows the attenuation (optical loss) for a particular material used in fibre-optic waveguides.

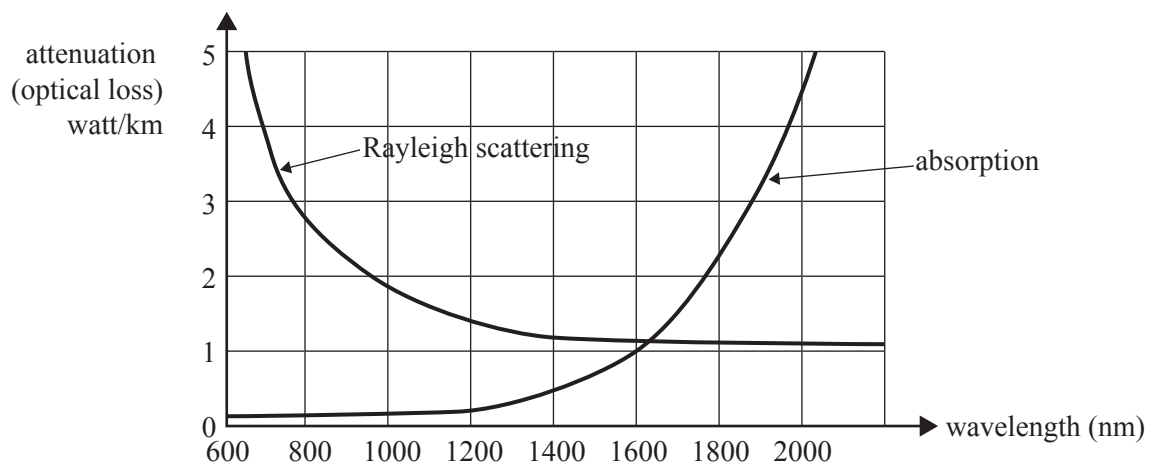

Figure 5

**Question 9**

An infrared laser of wavelength 2000 nm is used.

Which of the following would be the major cause of attenuation in the waveguide?

- A. modal dispersion
- B. material dispersion
- C. Rayleigh scattering
- D. absorption by material

**Question 10**

A long-distance data link using this particular material is being planned.

The designers wish to select the best wavelength to reduce signal loss in the system.

Which of the following wavelengths will give the least signal loss?

- A. 600 nm
- B. 1000 nm
- C. 1200 nm
- D. 1600 nm

NO WRITING ALLOWED IN THIS AREA

**Question 11**

Graded-index fibres, even though they are more expensive, are sometimes used in place of step-index fibres in optical transmission systems.

Graded-index fibres are used because they best reduce

- A. material dispersion.
  - B. modal dispersion.
  - C. Rayleigh scattering.
  - D. attenuation due to absorption.
- 

**Question 12**

Which of the following best explains the cause of Rayleigh scattering in an optical fibre?

- A. excessively sharp bending of the optical fibre
- B. absorption at the interface of the core and cladding
- C. small variations in density in the core of an optical fibre
- D. refractive index of the cladding being too similar to the refractive index of the core

NO WRITING ALLOWED IN THIS AREA

**Detailed study 3 – Sound**

*The following information relates to Questions 1 and 2.*

A loudspeaker producing a sound of constant frequency of 512 Hz is placed in a room, as shown in Figure 1. The speed of sound in air in the room is  $330 \text{ m s}^{-1}$ .

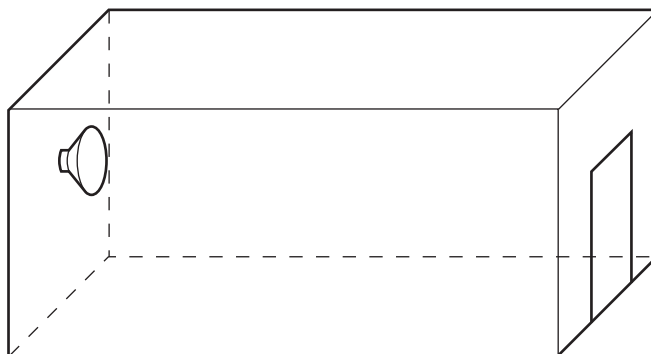

**Figure 1**

**Question 1**

Which of the following best gives the wavelength of the sound?

- A. 0.33 m
- B. 0.64 m
- C. 1.55 m
- D. 1.69 m

**Question 2**

Which of the following statements best describes the behaviour of air immediately in front of the speaker?

- A. It is moving away from the speaker at  $330 \text{ m s}^{-1}$ .
  - B. It is moving away from the speaker at  $512 \text{ m s}^{-1}$ .
  - C. It is oscillating vertically 512 times per second.
  - D. It is oscillating horizontally 512 times per second.
- 

NO WRITING ALLOWED IN THIS AREA

*The following information relates to Questions 3 and 4.*

Jane is standing at a distance 5.0 m from a sound source that emits sound of frequency of 500 Hz, **equally in all directions**.

She measures the sound intensity level to be 70 dB.

**Question 3**

Which of the following best gives the sound intensity ( $\text{W m}^{-2}$ ) at the point where Jane is standing?

- A.  $1.0 \times 10^{-5} \text{ W m}^{-2}$
- B.  $5.0 \times 10^{-5} \text{ W m}^{-2}$
- C.  $1.0 \times 10^{-7} \text{ W m}^{-2}$
- D.  $7.0 \times 10^{-12} \text{ W m}^{-2}$

**Question 4**

Richard is standing 20 m from the same sound source.

Which of the following best gives the sound intensity level that Richard will hear?

- A. 67 dB
  - B. 64 dB
  - C. 58 dB
  - D. 18 dB
-

**Question 5**

The graph in Figure 2 shows the relationship between sound intensity level (dB), frequency (Hz) and loudness (phon) for the human ear.

In a hearing test for Melanie, a sound source emits a steady tone of 200 Hz at a sound intensity level of 40 dB. Melanie hears this at a loudness of 20 phon.

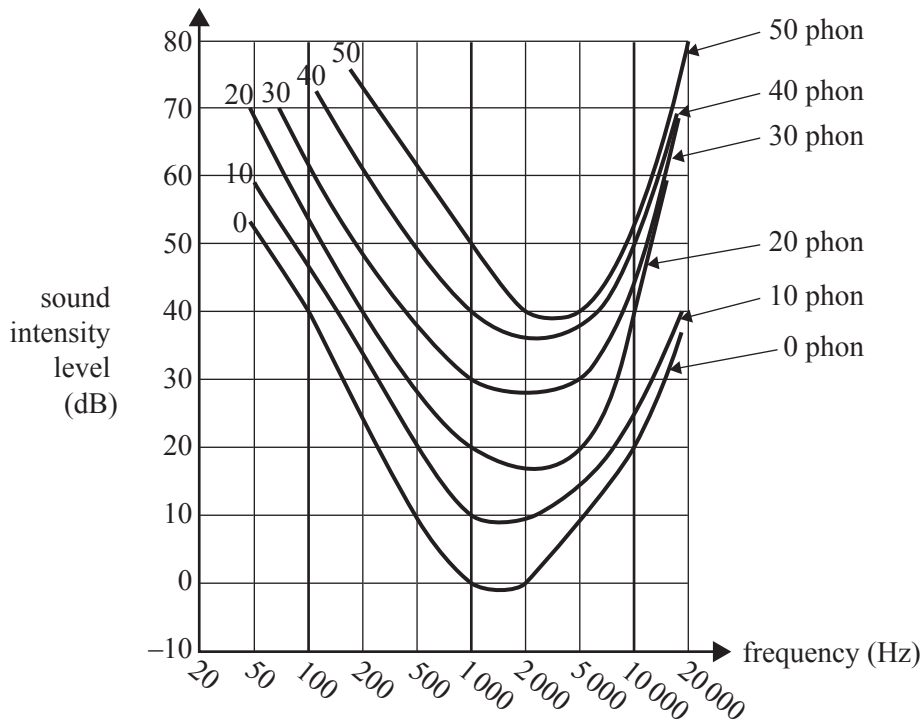

**Figure 2**

The frequency is now increased to 2000 Hz. The same sound intensity level is maintained.

Which of the following is the best estimate of the loudness at which Melanie will now hear the sound?

- A. 20 phon
- B. 40 phon
- C. 50 phon
- D. 80 phon

**NO WRITING ALLOWED IN THIS AREA**

The following information relates to Questions 6–8.

Max uses a narrow tube, open at one end and closed at the other, to construct one of the pipes for a pipe organ. He tests it by using a frequency generator and a loudspeaker as shown in Figure 3.

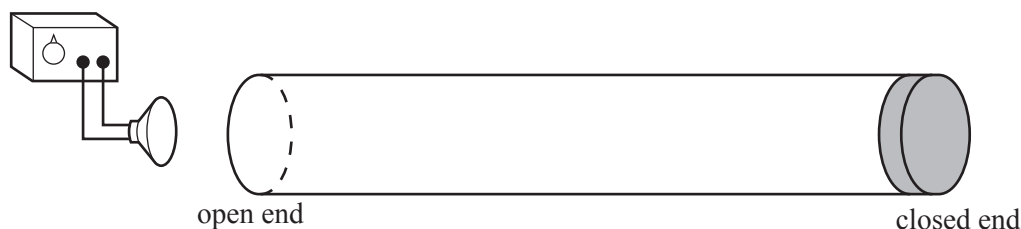

Figure 3

The speed of sound under the conditions of the test is  $320 \text{ m s}^{-1}$ .

Max finds that the fundamental frequency is 133 Hz.

**Question 6**

Which of the following best gives the length of the tube?

- A. 3.2 m
- B. 2.4 m
- C. 1.2 m
- D. 0.6 m

**Question 7**

Which of the following best gives the next higher resonant frequency that Max will hear?

- A. 200 Hz
- B. 267 Hz
- C. 400 Hz
- D. 532 Hz

**Question 8**

Max now takes the cover off the other end of the pipe, so that it is open at both ends.

Which of the following best gives the frequency at which Max will now hear the fundamental resonance?

- A. 133 Hz
- B. 200 Hz
- C. 266 Hz
- D. 400 Hz

The following information relates to Questions 9 and 10.

The frequency response curve for a particular microphone is shown in Figure 4 below.

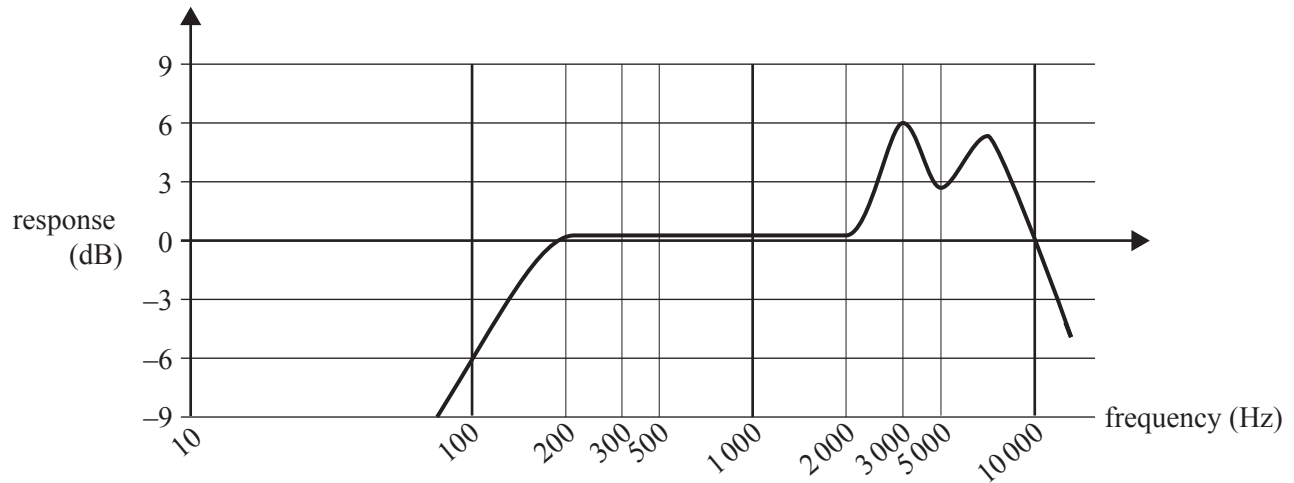

Figure 4

**Question 9**

Which of the following best gives the range of frequencies over which the microphone is likely to operate with good fidelity?

- A. 200–10 000 Hz
- B. 200–2 000 Hz
- C. 100–5 000 Hz
- D. 2 000–10 000 Hz

NO WRITING ALLOWED IN THIS AREA



**Question 10**

To test the frequency response of the microphone, a variable frequency sound source is used.

The sound emits a pure tone of 1000 Hz, followed by a pure tone of 3000 Hz. The sound source is adjusted so that the two tones have the same sound intensity at the microphone. In the diagrams below, first a 1000 Hz and then a 3000 Hz signal are displayed on an oscilloscope.

Which display best shows what will be observed on the oscilloscope?

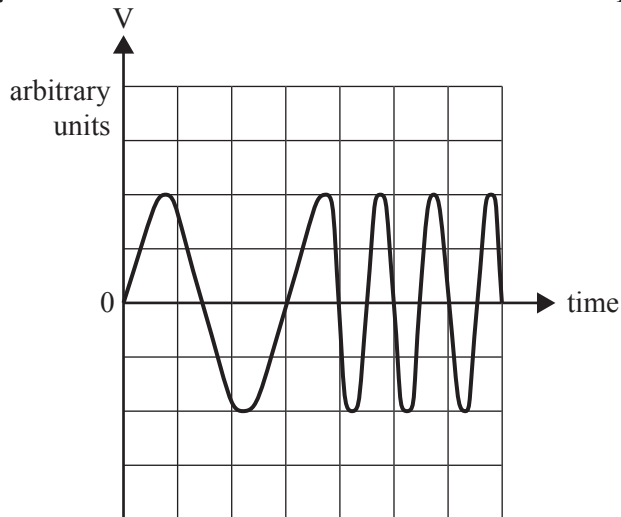
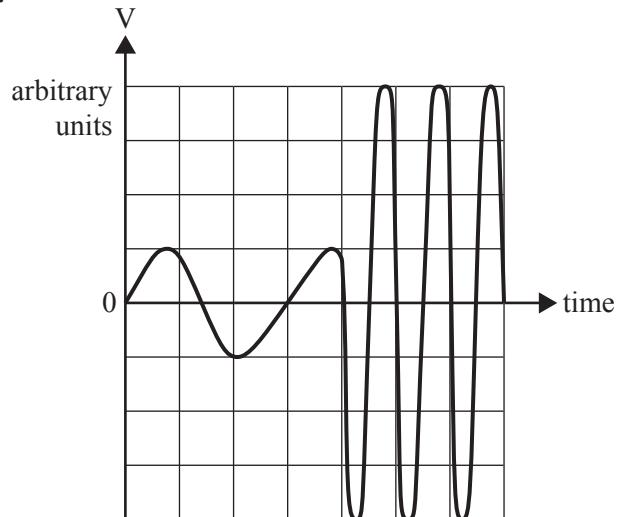
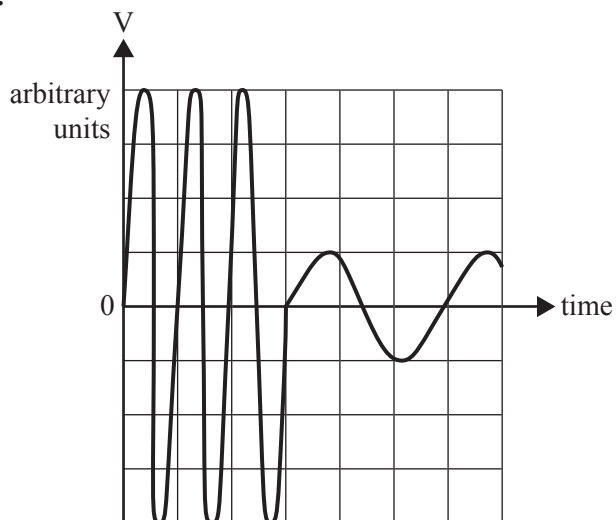
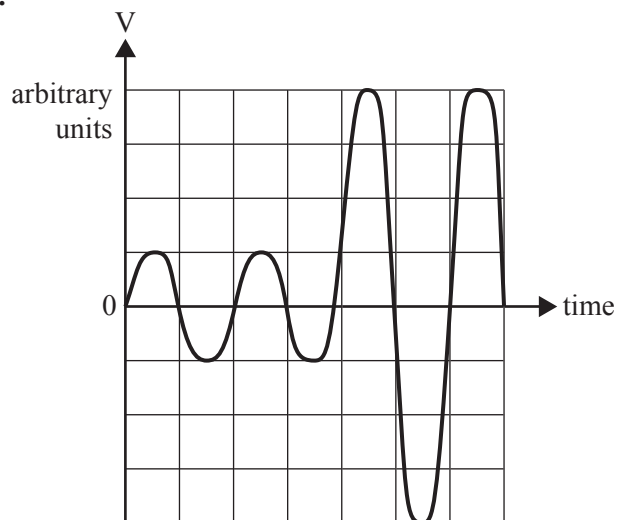
**A.****B.****C.****D.**

NO WRITING ALLOWED IN THIS AREA

**Question 11**

Millie and Micky are testing a loudspeaker. They set it up as shown in Figure 5a.

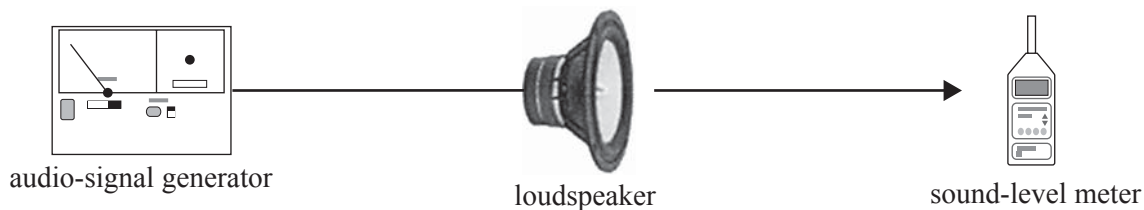

**Figure 5a**

The sound is not sufficiently loud. They add a large baffle board, as shown in Figure 5b. The intensity of the sound is increased at the sound-level meter.

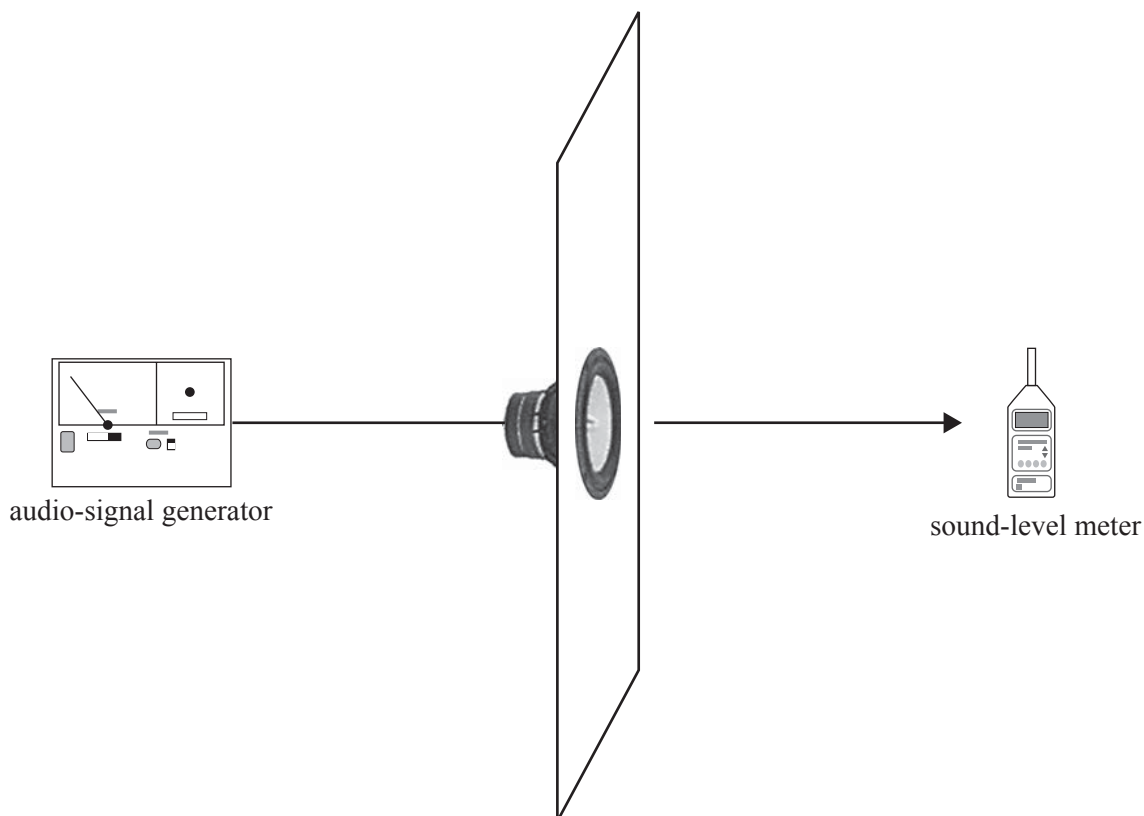

**Figure 5b**

What is the best explanation of this improvement?

- A. The baffle board prevents interference between waves from the front and back of the loudspeaker.
  - B. The baffle board prevents sound travelling out vertically, and so more reaches the meter.
  - C. The baffle board also oscillates with the loudspeaker, so sending out more sound waves.
  - D. There is resonance between the baffle board and the loudspeaker.
- 

**NO WRITING ALLOWED IN THIS AREA**

**Question 12**

Chris and Tony are setting up a home entertainment system which consists of a television screen and four speakers. They use one speaker optimised for low frequencies, two speakers for the middle frequencies, and one for higher frequencies. They set up the speaker system as shown in Figure 6a, and the fidelity of the sound is excellent.

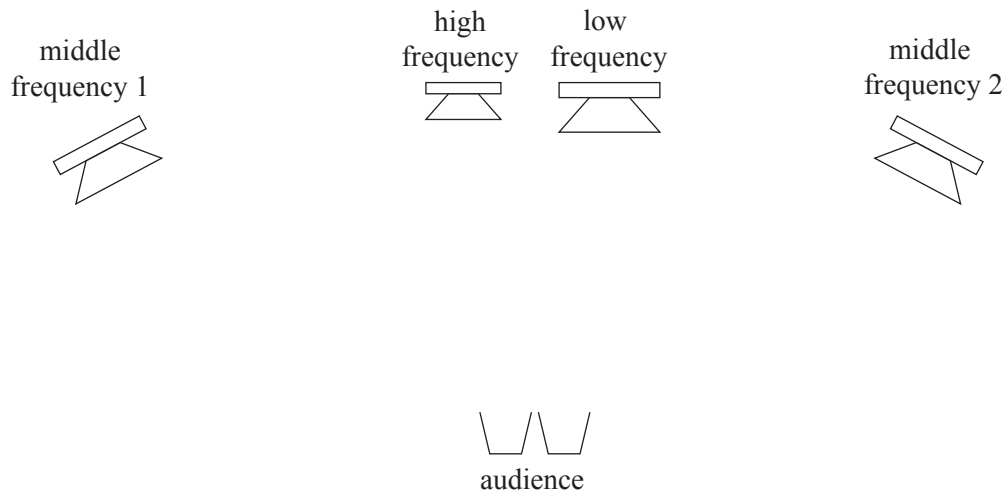
**Figure 6a**

They then set up the television as shown in Figure 6b. The sound is now of lower fidelity.

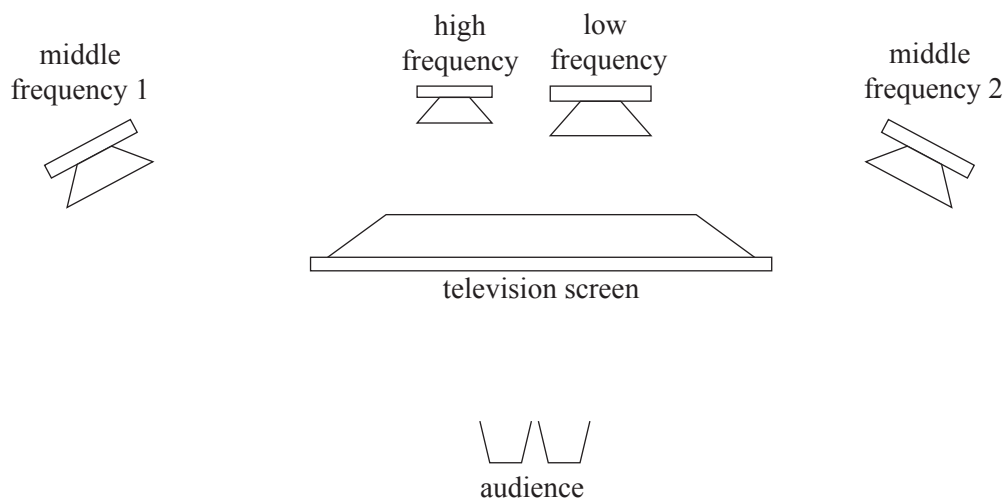
**Figure 6b**

What is the best explanation for this deterioration in fidelity of the sound?

- There will now be an interference pattern from the two middle-range speakers that did not exist before.
- The television screen acts as a baffle board, and so the sound from the low and high frequency speakers is now much louder than the other two speakers.
- The sound from the high frequency speaker diffracts around the television sufficiently, but the sound from the low frequency speaker does not.
- The sound from the low frequency speaker diffracts around the television sufficiently, but the sound from the high frequency speaker does not.



**Victorian Certificate of Education  
2010**

**PHYSICS**  
**Written examination 2**

**Wednesday 10 November 2010**

**Reading time: 11.45 am to 12.00 noon (15 minutes)**

**Writing time: 12.00 noon to 1.30 pm (1 hour 30 minutes)**

**FORMULA SHEET**

**Directions to students**

- A question and answer book is provided with this formula sheet.

**Students are NOT permitted to bring mobile phones and/or any other unauthorised electronic devices into the examination room.**

1	photoelectric effect	$E_{K \max} = hf - W$
2	photon energy	$E = hf$
3	photon momentum	$p = \frac{h}{\lambda}$
4	de Broglie wavelength	$\lambda = \frac{h}{p}$
5	resistors in series	$R_T = R_1 + R_2$
6	resistors in parallel	$\frac{1}{R_T} = \frac{1}{R_1} + \frac{1}{R_2}$
7	magnetic force	$F = I l B$
8	electromagnetic induction	emf : $\varepsilon = -N \frac{\Delta \Phi}{\Delta t}$ flux: $\Phi = BA$
9	transformer action	$\frac{V_1}{V_2} = \frac{N_1}{N_2}$
10	AC voltage and current	$V_{\text{RMS}} = \frac{1}{\sqrt{2}} V_{\text{peak}}$ $I_{\text{RMS}} = \frac{1}{\sqrt{2}} I_{\text{peak}}$
11	voltage; power	$V = RI$ $P = VI$
12	transmission losses	$V_{\text{drop}} = I_{\text{line}} R_{\text{line}}$ $P_{\text{loss}} = I_{\text{line}}^2 R_{\text{line}}$
13	mass of the electron	$m_e = 9.1 \times 10^{-31} \text{ kg}$
14	charge on the electron	$e = -1.6 \times 10^{-19} \text{ C}$
15	Planck's constant	$h = 6.63 \times 10^{-34} \text{ J s}$ $h = 4.14 \times 10^{-15} \text{ eV s}$
16	speed of light	$c = 3.0 \times 10^8 \text{ m s}^{-1}$
17	Acceleration due to gravity at Earth's surface	$g = 10 \text{ m s}^{-2}$

### Detailed study 3.1 – Synchrotron and applications

18	energy transformations for electrons in an electron gun (<100 keV)	$\frac{1}{2} m v^2 = eV$
19	radius of electron beam	$r = mv/eB$
20	force on an electron	$F = evB$
21	Bragg's law	$n\lambda = 2d \sin \theta$
22	electric field between charged plates	$E = \frac{V}{d}$

**Detailed study 3.2 – Photonics**

23	band gap energy	$E = \frac{hc}{\lambda}$
24	Snell's law	$n_1 \sin i = n_2 \sin r$

**Detailed study 3.3 – Sound**

25	speed, frequency and wavelength	$v = f\lambda$
26	intensity and levels	<p>sound intensity level  (in dB) = <math>10 \log_{10} \left( \frac{I}{I_0} \right)</math>  where <math>I_0 = 1.0 \times 10^{-12} \text{ W m}^{-2}</math></p>

**Prefixes/Units**

p = pico =  $10^{-12}$

n = nano =  $10^{-9}$

$\mu$  = micro =  $10^{-6}$

m = milli =  $10^{-3}$

k = kilo =  $10^3$

M = mega =  $10^6$

G = giga =  $10^9$

t = tonne =  $10^3 \text{ kg}$