



# Victorian Certificate of Education 2002

SUPERVISOR TO ATTACH PROCESSING LABEL HERE

## STUDENT NUMBER

Figures

Words

Letter

--

# PHYSICS

## Written examination 1

Wednesday 12 June 2002

Reading time: 11.45 am to 12.00 noon (15 minutes)

Writing time: 12.00 noon to 1.30 pm (1 hour 30 minutes)

## QUESTION AND ANSWER BOOK

### Structure of book

<i>Area</i>	<i>Number of questions</i>	<i>Number of questions to be answered</i>	<i>Number of marks</i>	<i>Suggested times (minutes)</i>
1. Sound	12	12	30	30
2. Electric power	13	13	30	30
3. Electronic systems	17	17	30	30
			Total 90	90

- Students are permitted to bring into the examination room: pens, pencils, highlighters, erasers, sharpeners, rulers, up to two pages (one A4 sheet) of pre-written notes (typed or handwritten) and an approved graphics calculator (memory cleared) and/or one scientific calculator.
- Students are NOT permitted to bring into the examination room: blank sheets of paper and/or white out liquid/tape.

### Materials supplied

- Question and answer book of 27 pages, with a detachable formula sheet in the centrefold.

### Instructions

- Detach the formula sheet from the centre of this book during reading time.
- Write your **student number** in the space provided above on this page.
- Answer all questions in this question and answer book where indicated.
- **Always** show your working where space is provided and place your answer(s) to multiple-choice questions in the box provided.
- All written responses must be in English.

**Students are NOT permitted to bring mobile phones and/or any other electronic communication devices into the examination room.**

**AREA 1 – Sound**

Ashley and Pat have a method for determining the speed of sound. Ashley beats a drum at a rate of exactly two beats per second. Pat then walks away from Ashley along the street until the sound of the drum is heard at the precise instant Ashley is seen to hit the drum. The distance from the drum to Pat at this point is 167 m.

**Question 1**

What is the calculated speed of sound? Your answer must be given to three significant figures.

$\text{m s}^{-1}$
-------------------

2 marks

Two students, Pat and Morgan, are discussing an experiment to test the nature of sound waves. They imagine a loudspeaker with a dust particle sitting motionless in front of it, and consider what will happen to the particle when the speaker is turned on.

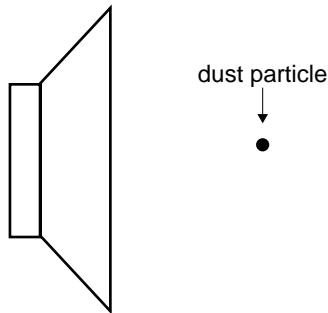

**Figure 1**

**Pat** says that since there is energy transferred by the wave, the particle will gain energy. A succession of little impulses will push the particle continuously away from the speaker.

**Morgan** agrees that energy is carried by the wave. However, the result of the pressure variations will cause the dust particle to move back and forth about its original position.

**Question 2**

Circle the name of the person whose prediction is more nearly correct.

Pat / Morgan

Explain the logic of your choice.

---



---



---



---



---



---



---



---



---

4 marks

The following diagrams represent the variation of air pressure of a sound wave of period  $T$ , as a function of distance, at a particular time. Diagram A was recorded at time  $t = 0$ . The other diagrams (**B–E**) show the pressure variation at later times.

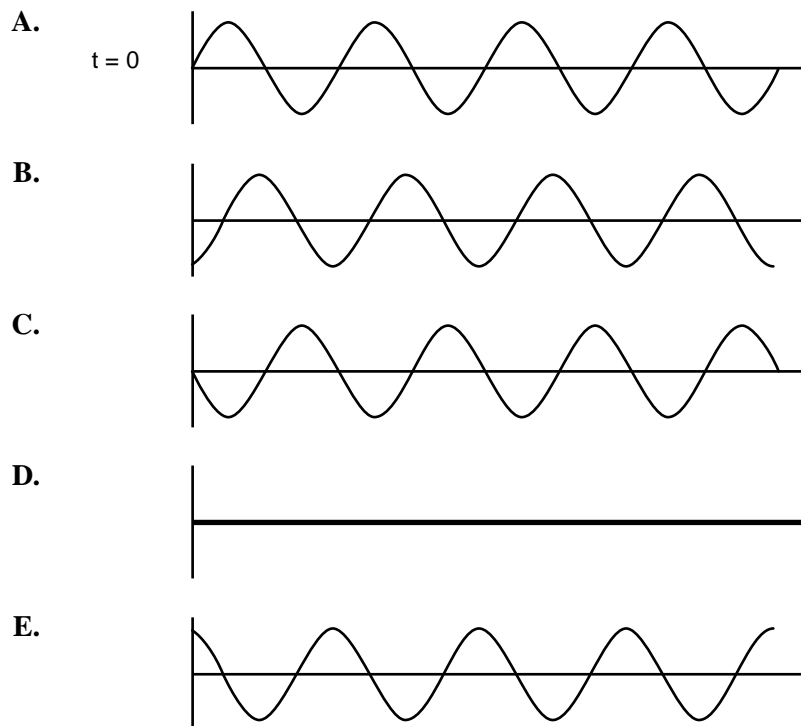

**Question 3**

Write the letters (**A–E**) of the diagrams that correspond to a sound wave travelling to the left at times  $t = T/4$ , and  $T/2$ , later than diagram A.

$T/4$	$T/2$
-------	-------

2 marks

**Question 4**

Write the letters (**A–E**) of the diagrams that correspond to a standing wave at times  $t = T/4$ , and  $T/2$ , later than diagram A.

$T/4$	$T/2$
-------	-------

2 marks

Two speakers are mounted on a wall in the school gymnasium. One speaker is at head-height and the other is 3 m directly above it. The speakers are connected to the same amplifier, and emit sound waves in phase with a wavelength of 2 m. The speed of sound in air is  $340 \text{ m s}^{-1}$ .



**Figure 2**

A student walks from the far end of the gym towards the lower speaker. Although the sound is quite audible, at a certain distance from the speaker it becomes soft, then increases again.

**Question 5**

How far is the student from the lower speaker when the sound level first becomes a minimum?

	m
--	---

4 marks



Figure 4 is a plot of the hearing sensitivity response of an average person. It represents the minimum sound intensity that can be heard as a function of frequency.

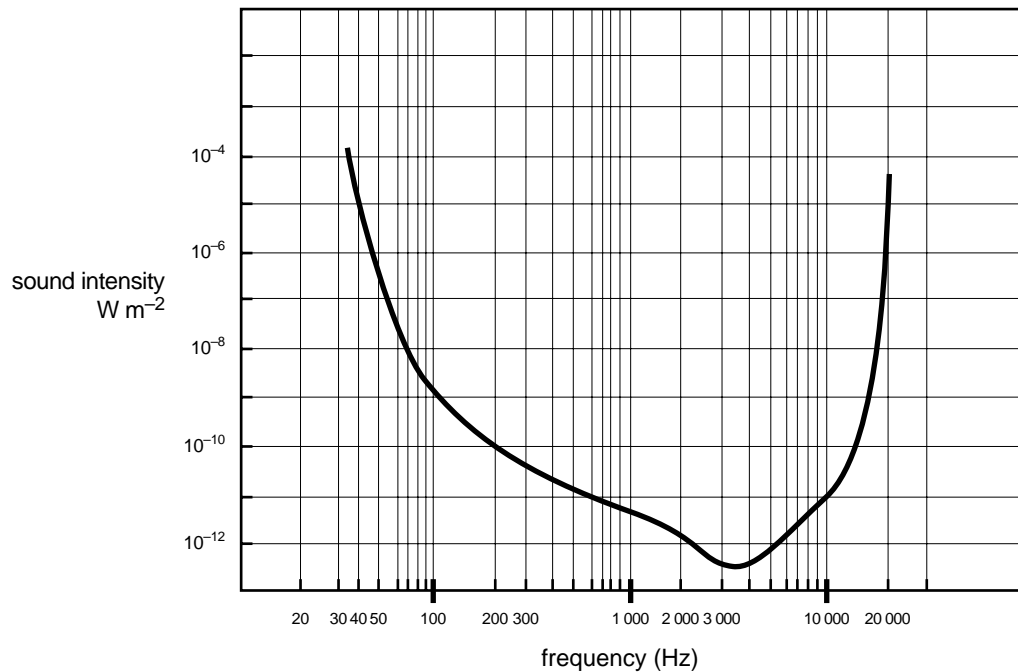

Figure 4

Abdul is listening to music with the volume of his stereo turned very high, such that the sound intensity at his ears is  $10^{-5} \text{ W m}^{-2}$ .

### Question 7

What are the lowest and highest frequencies that he can hear?

Lowest	Hz	Highest	Hz
--------	----	---------	----

2 marks

However, his mother comes in and turns down the volume, so that the sound intensity at his ears is now only  $10^{-9} \text{ W m}^{-2}$ .

### Question 8

By how many decibel was the sound intensity level reduced?

	dB
--	----

2 marks

The speaker system for a school sports meeting is arranged so that it emits sound equally in all directions. It consists of a group of speakers attached to a central post as shown in Figure 5.

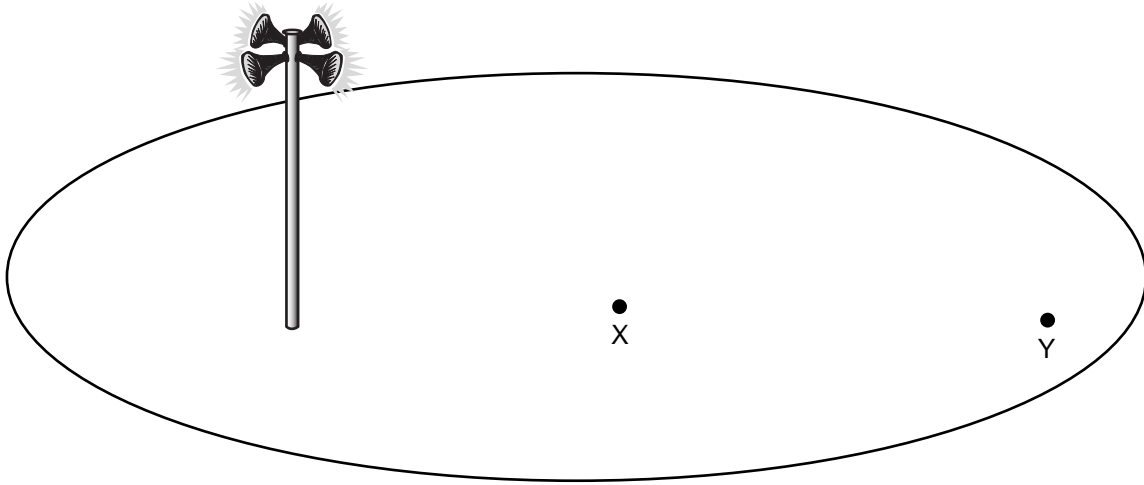

Figure 5

X and Y denote two points on the school oval, with Y being **twice** as far away **from the speakers** as X. The sound intensity at X due to the speakers is  $I_0 \text{ W m}^{-2}$ .

**Question 9**

Which of the values (A–D) below is closest to the sound intensity at position Y?

- A.  $I_0/4$       B.  $I_0/2$       C.  $I_0$       D.  $2I_0$

2 marks



A clarinet is a wind instrument that can be modelled as a tube closed at one end. Assume that the pressure nodes and antinodes occur exactly at the end of the tube.

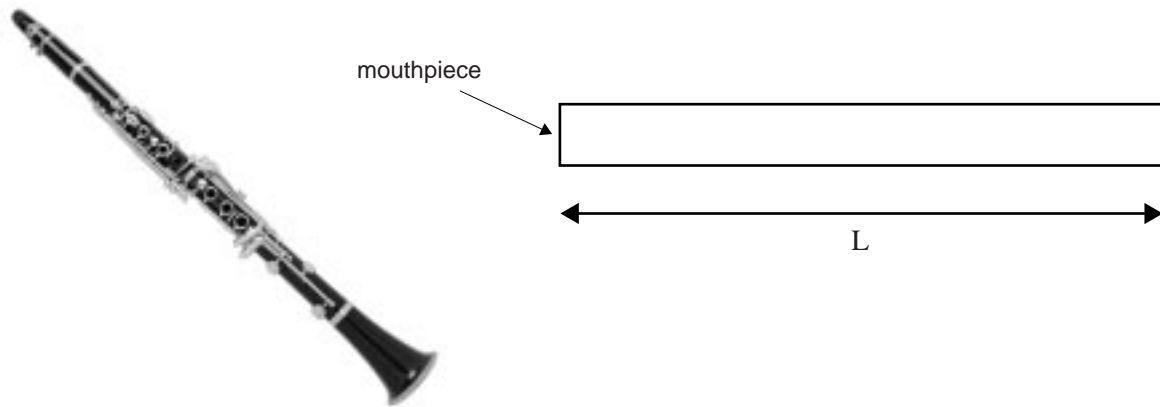

Figure 6

The clarinet has a fundamental frequency of 130 Hz.

**Question 10**

What is the length ( $L$ ) of the tube that models the clarinet? The speed of sound in air is  $340 \text{ m s}^{-1}$ .

 m

2 marks

The clarinet is now played to produce the overtone at 650 Hz.

**Question 11**

Which of the figures below (A–E) best represents the standing pressure wave in the tube that models the clarinet?

- A.
- B.
- C.
- D.
- E.

2 marks

**AREA 1 – continued**  
**TURN OVER**

Figure 7 below represents the variation of the pressure of the sound wave with time, when the fundamental frequency of 130 Hz is played on the clarinet.

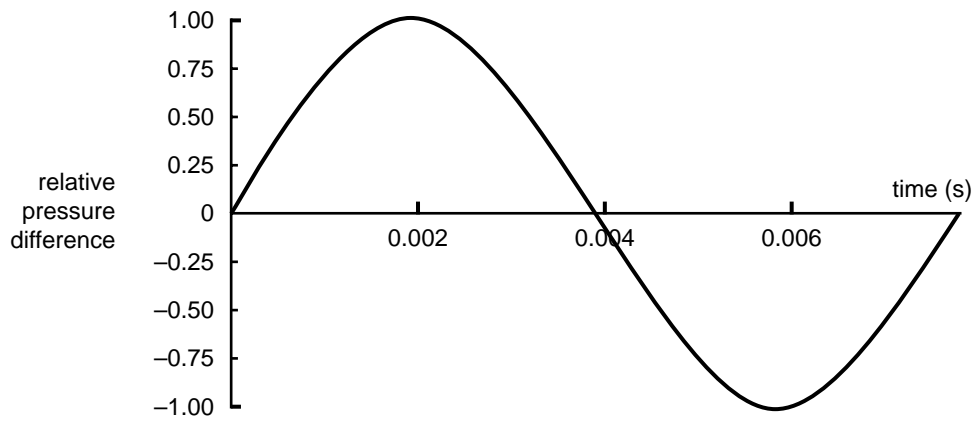

Figure 7

**Question 12**

On Figure 7 above, sketch the variation of the relative pressure difference with time, of the sound wave when the first overtone is played on the clarinet.

2 marks

**AREA 2 – Electric power**

The 60-watt light bulb in Sam's desk lamp has burnt out. There is no spare replacement that operates on the 240-V supply. However, a 60-watt light bulb is found that operates at 120 V. Sam suggests building the following circuit in order to use the 120-V light bulb.

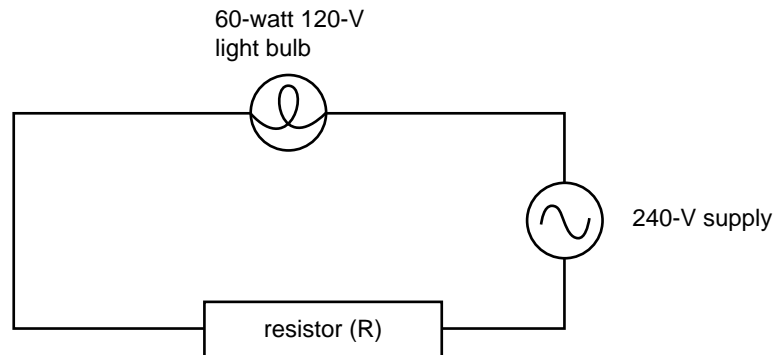
**Figure 1****Question 1**

What is the value of the resistor R that will allow the 120-V light bulb to operate correctly?

ohm
-----

3 marks

The Smith family and the Jones family are farmers near Warragul. Their electricity supply comes more than 100 km, from a power station in the LaTrobe valley. It is carried by transmission lines, at a voltage of  $220 \text{ kV}_{\text{RMS}}$ . Near the town, a switchyard-transformer (T1) steps the voltage down to  $10 \text{ kV}_{\text{RMS}}$  for the local area. A  $10\text{-kV}_{\text{RMS}}$  line runs to the Jones' farm, where there is a transformer (T2) that provides  $240 \text{ V}_{\text{RMS}}$  for the farms. A  $240\text{-V}_{\text{RMS}}$  line then runs 2 km to the Smith's farm. A sketch of the situation is shown below. The transformers can be considered to be ideal.

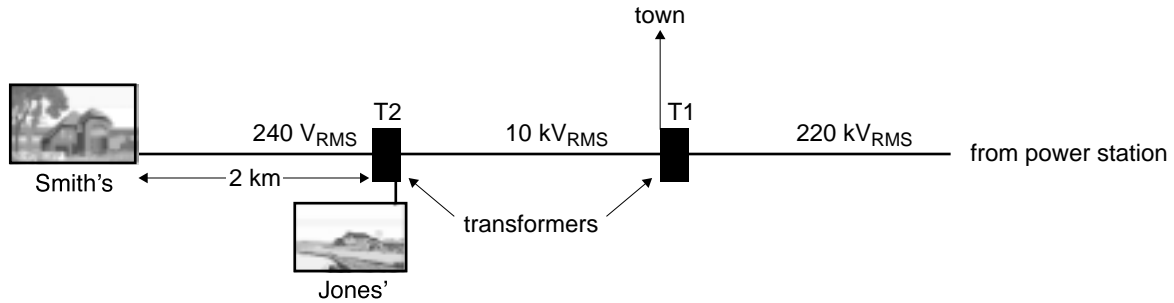

Figure 2

**Question 2**

Explain why the supply from the power station to the local area is chosen to be  $220 \text{ kV}_{\text{RMS}}$  rather than at  $240 \text{ V}_{\text{RMS}}$ . Use numerical estimates to support your answer.

---

---

---

---

---

---

---

---

---

---

3 marks

Assume that the input voltage to transformer T1 is  $220 \text{ kV}_{\text{RMS}}$ , and the output is  $10 \text{ kV}_{\text{RMS}}$ .

**Question 3**

What is the value of the ratio:

$$\frac{\text{number of turns on the primary coil}}{\text{number of turns on the secondary coil}}$$

1 mark

The supply and the return lines between transformer T2 and the Smith's farm have a total resistance of  $0.0004 \text{ ohm m}^{-1}$ .

At a particular time, 20 A of current is being supplied to the Smith's farm. Assume that the potential at the secondary for transformer T2 is  $240 \text{ V}_{\text{RMS}}$ .

**Question 4**

What is the voltage at the Smith's farm?

$V_{\text{RMS}}$
------------------

3 marks

Sometimes strings of Christmas-tree lights consist of three groups of globes that are connected as shown in Figure 3.

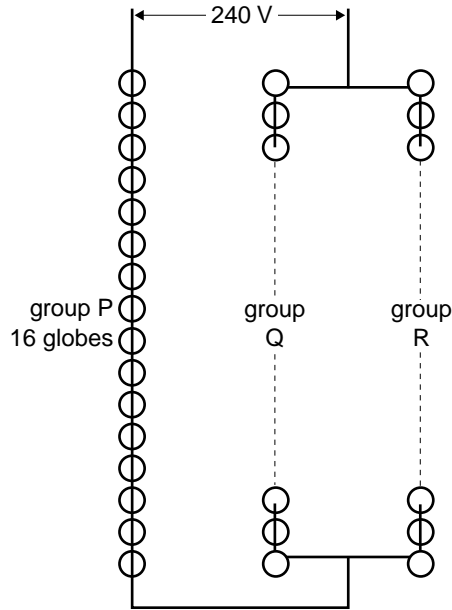

Figure 3

There are 16 globes in group P. Each of the globes has a voltage of 10 V across it and a current of 0.50 A flowing through it when the string of lights is operating as designed. The globes in groups Q and R have a different power rating to those in group P.

The number of globes in groups Q and R is equal. Although they have a different power rating from the globes in group P, the potential difference across each globe is still 10 V when operating.

**Question 5**

How many globes are there in group Q?

2 marks

**Question 6**

What current is being supplied from the electricity supply to the string of lights?

2 marks

Assume that the power rating of all globes in Q and R are identical.

**Question 7**

How much power is dissipated by each globe in groups Q and R?

W
---

3 marks

One of the globes in group Q burns out.

**Question 8**

Indicate in the box beside each group whether the globes in that group are on or off. **If the group is on**, indicate whether the globe is **brighter** or **dimmer** compared to when the system is operating correctly.

Group	ON/OFF	Brightness
P		
Q		
R		

3 marks

Jackie and Jim are studying electromagnetic induction. They have a small permanent magnet and a coil of wire wound around a hollow cylinder as shown in Figure 4.

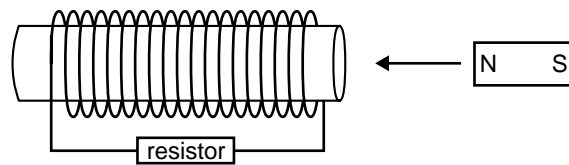

Figure 4

Jackie moves the magnet through the coil in the direction shown at constant speed.

**Question 9**

Indicate on the diagram the direction of the induced current that flows in the resistor. Explain the physics reason for your choice.

---



---



---



---



---

2 marks

They next decide to move the magnet, at a constant speed, all the way through the coil and out the other side.

**Question 10**

Which **one** of the diagrams (A–D) below best shows how the current through the coil varies with time?

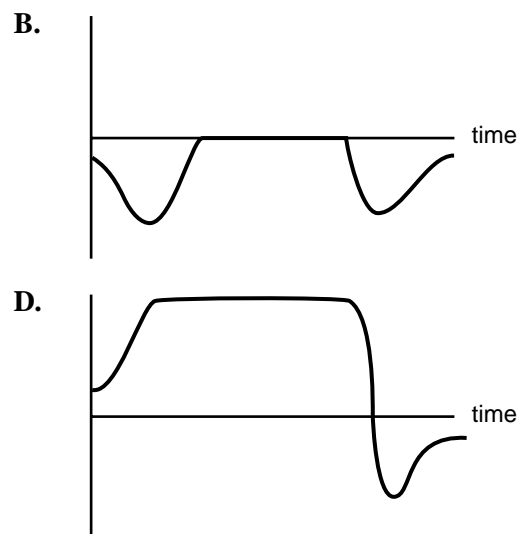
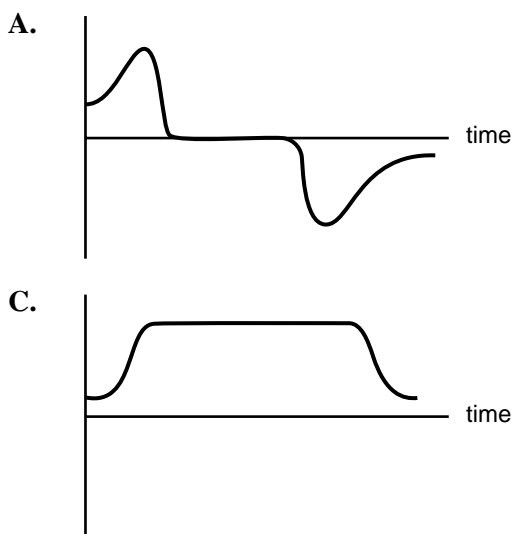

2 marks



The circuit of a simple DC electric motor is shown in Figure 5. It consists of a current-carrying coil of 50 turns as the armature. The coil is square with sides of 5.0 cm. The coil is in a uniform magnetic field of strength 0.005 T.

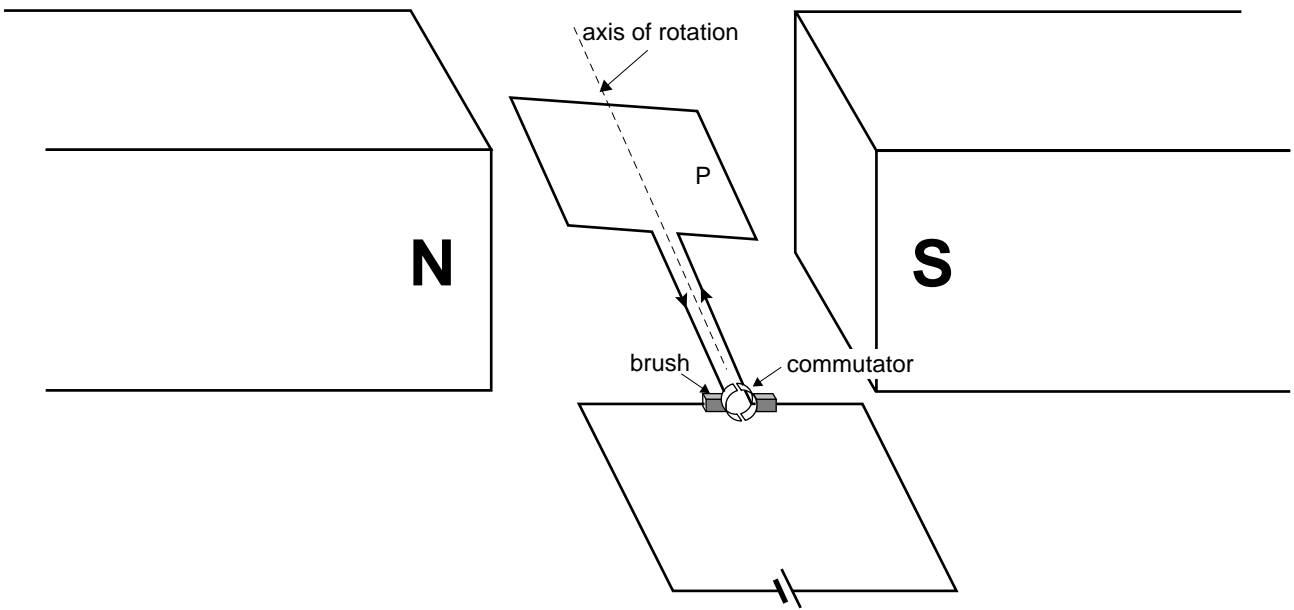

Figure 5

A current of 3.0 A flows through the coil in the direction shown in Figure 5.

**Question 11**

Calculate the magnitude of the force exerted on the 50 wires of side P of the coil.

N

2 marks

**Question 12**

When the coil is in the position shown in Figure 5, which of the directions (A–D) below best shows the direction of the force exerted on side P of the coil?

- A.      B.      C.      D.

1 mark



**This page is blank**

**TURN OVER**

**AREA 3 – Electronic systems**

Your Physics teacher connects a cathode ray oscilloscope (CRO) to an AC voltage source. The voltage is known to be sinusoidal with a peak-to-peak voltage of 12 V and a period of 100 ms.

**Question 1**

What is the RMS value of the sinusoidal voltage?

 V

2 marks

The CRO screen is shown in Figure 1 where vertical and horizontal lines are 1 cm apart as indicated.

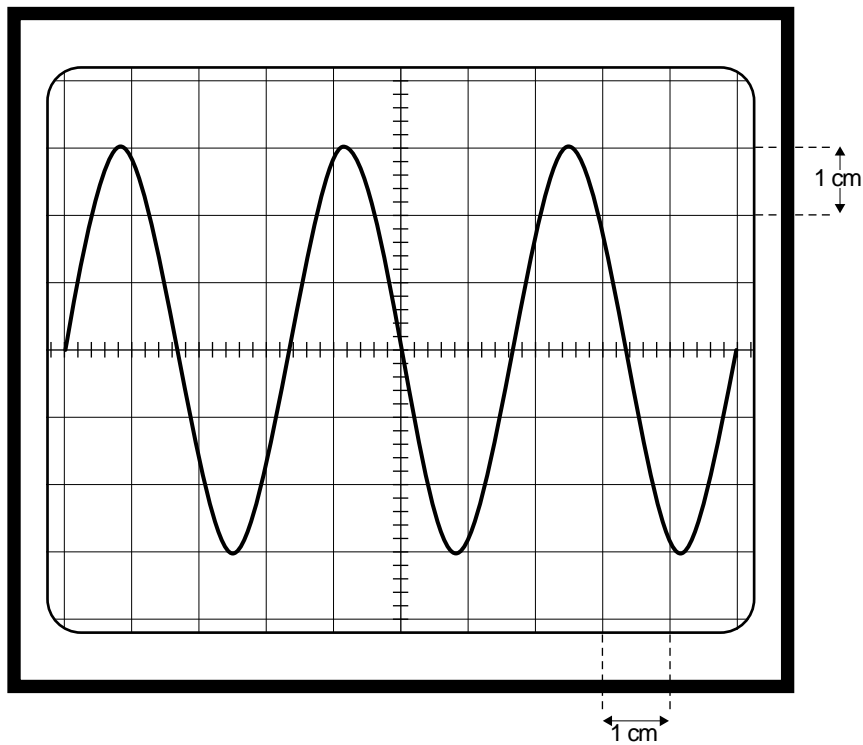

**Figure 1**

**Question 2**

What voltage change is represented by 1 cm in the vertical direction on the CRO screen?

 V

2 marks

**Question 3**

What time interval is represented by 1 cm in the horizontal direction on the CRO screen?

 ms

2 marks

Students construct a digital electronic system to demonstrate traffic lights as shown in Figure 2. Signal  $V_0$  has a period of 3.0 s, and is the input to a rising-edge flip-flop used to produce an output square wave,  $V_1$ . Over one period the voltage,  $V_0$ , is ON (logic level 1) for 1.5 s and then OFF (logic level 0) for the next 1.5 s.

#### Question 4

Complete the timing diagram of Figure 2 for the signal  $V_1$ .

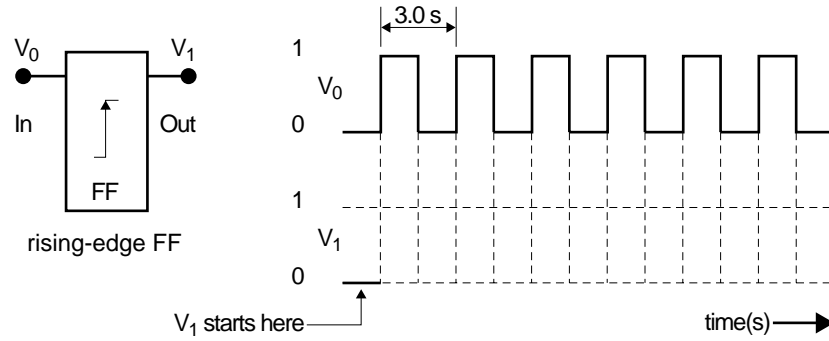

Figure 2

2 marks

#### Question 5

Starting with the voltage waveform  $V_0$ , what is the total number of these flip-flop circuits required to produce a digital voltage signal with a period of 192 s (96 s ON then 96 s OFF)?

Number of flip-flop circuits =

2 marks

Three digital voltage signals,  $V_2$ ,  $V_3$  and  $V_4$  are illustrated in Figure 3a. The traffic lights are controlled by these signals using logic gates where necessary. A light goes ON when the voltage is logic 1, and is OFF when logic 0. The red light is ON for the first 96 s only, and the correct connection for the controlling circuit is shown in Figure 3b.

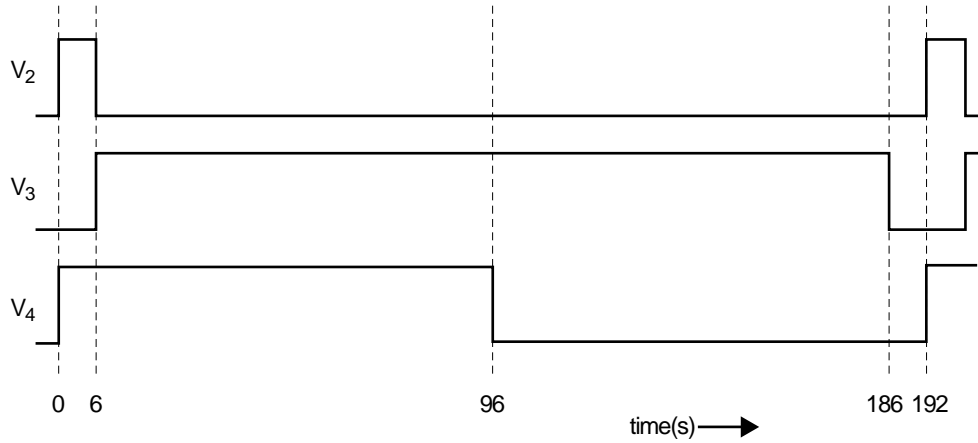

Figure 3a

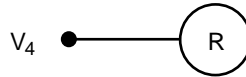
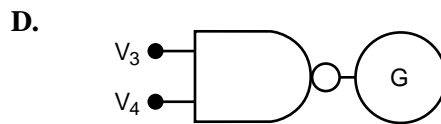
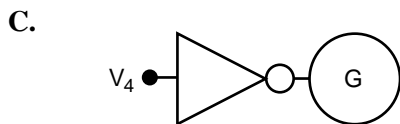
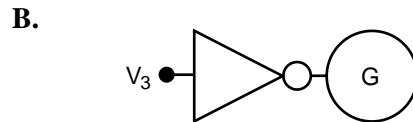
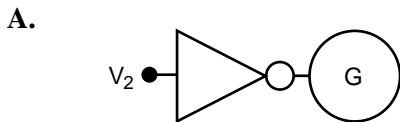

Figure 3b

**Question 6**

Using the signals of Figure 3a, which of the following controller logic circuits (A–D) will turn ON the green light for **only** the last 96 s of the 192 s cycle of the traffic signals?



1 mark

A yellow light is now added to the system and the green-light controller altered. The new traffic light sequence for the 192 s cycle is:

- red light only ON for the first 96 s
- then green light only ON for the next 90 s (96 to 186 s)
- then yellow light only ON for the last 6 s (186 to 192 s)
- then whole cycle repeated

**Question 7**

Using one 2-input logic gate, complete the logic controller circuit below (Figure 4) in order to activate the yellow traffic light according to the sequence above. The red and green light circuits are completed for you.

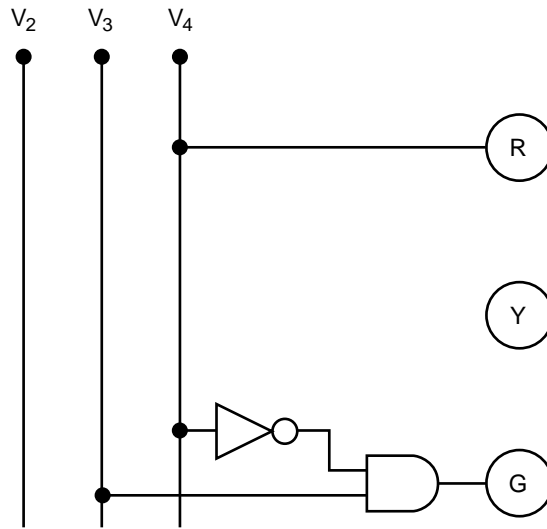

**Figure 4**

2 marks

**Question 8**

From Figure 4 complete the truth table for the green-light controller logic circuit.

$V_3$	$V_4$	G
0	0	
0	1	
1	0	
1	1	

2 marks

The current-voltage (I-V) characteristic curve of a nonlinear device is shown in Figure 5a. This device is connected in series with a  $100\text{-}\Omega$  resistor and placed across a  $5.0\text{ V}$  DC power supply as in Figure 5b. The voltage across the  $100\text{-}\Omega$  resistor is  $2.0\text{ V}$ .

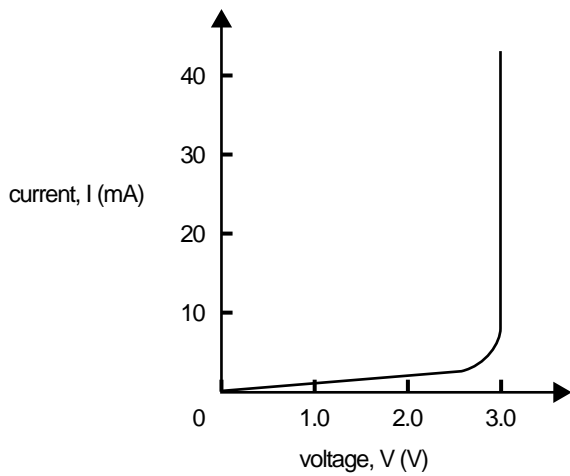

Figure 5a

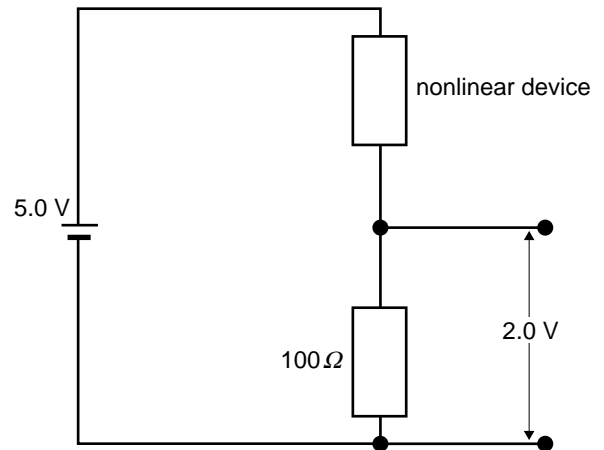

Figure 5b

**Question 9**

On the I-V characteristics, Figure 5a, indicate the point on the curve that identifies the voltage across, and current through, the nonlinear device.

1 mark

**Question 10**

In 10 seconds, how much electrical energy is converted to heat energy in the  $100\text{-}\Omega$  resistor?

mJ

2 marks

**Question 11**

If the  $100\text{-}\Omega$  resistor is replaced by a  $200\text{-}\Omega$  resistor, what now is the voltage across the nonlinear device?

V

2 marks

**Question 12**

With the  $100\text{-}\Omega$  resistor placed back in the circuit, the DC voltage of the battery is now increased from  $5.0\text{ V}$  to  $6.0\text{ V}$ . Which of the following expressions (A–D) best represents the resulting current through the nonlinear device?

- A. 16 mA                      B. 20 mA
- C. 24 mA                      D. 30 mA

1 mark



A DC power supply can be designed around a half-wave rectifying and smoothing circuit.

### Question 13

Figure 6 below is a sinusoidal voltage waveform. On the same set of axes sketch a half-wave rectified version of this waveform.

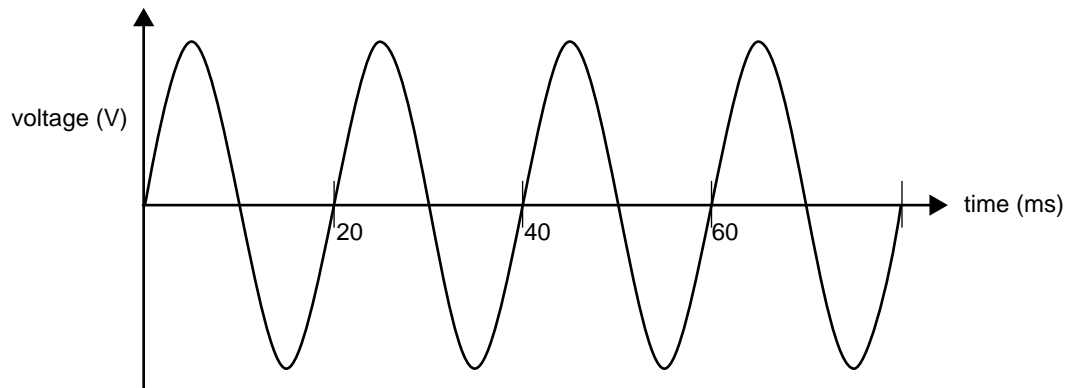

Figure 6

2 marks

Figure 7 shows a possible circuit for the DC power supply.

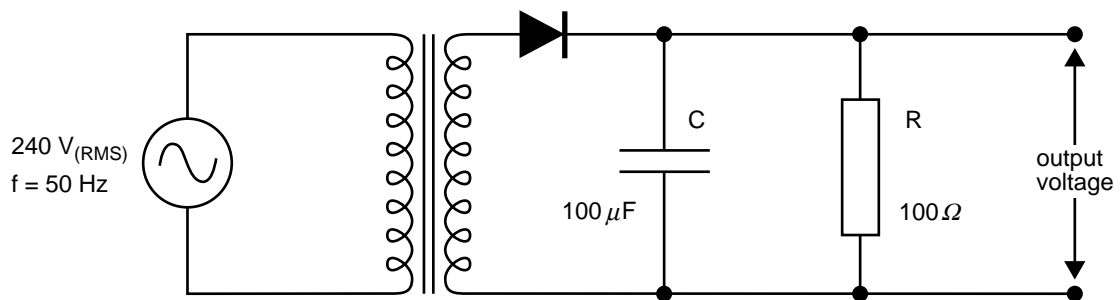

Figure 7

### Question 14

Using the information given in Figure 7, calculate the smoothing time constant.

ms
----

2 marks

**Question 15**

The resistor of Figure 7 is now removed from the circuit. No other changes are made. Which waveform (A–D) best represents the output voltage?

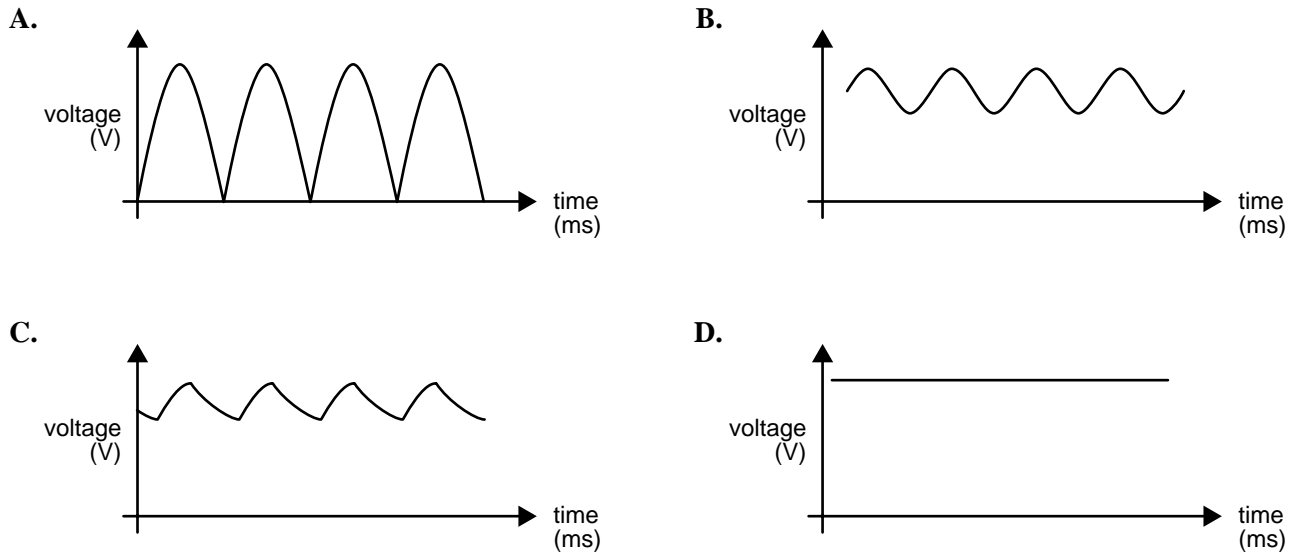

1 mark

You are provided with a linear voltage amplifier with a fixed voltage gain of 20. The circuit is shown in Figure 8. The input voltage to the amplifier is 0.1 V DC.

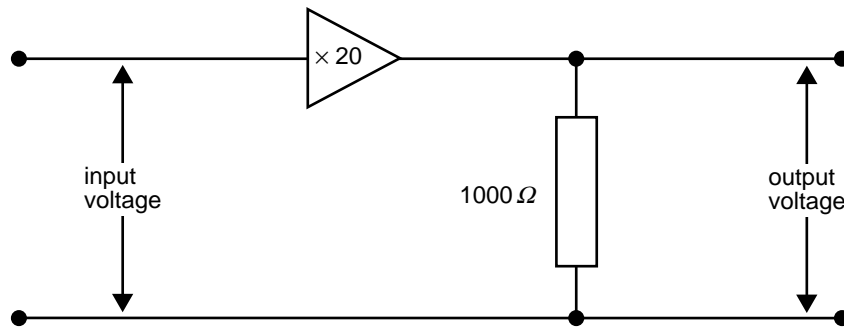

**Figure 8**

**Question 16**

What is the current in the 1000 Ω resistor?

2 marks

**Question 17**

This amplifier is now used to amplify a square-wave voltage with a peak-to-peak voltage of 0.2 V. Figure 9a shows the input voltage waveform.

On the axis given in Figure 9b, sketch the output of the amplifier using the same time scale as for the input voltage. As part of your answer you are to include the vertical scale for the output voltage waveform you have drawn.

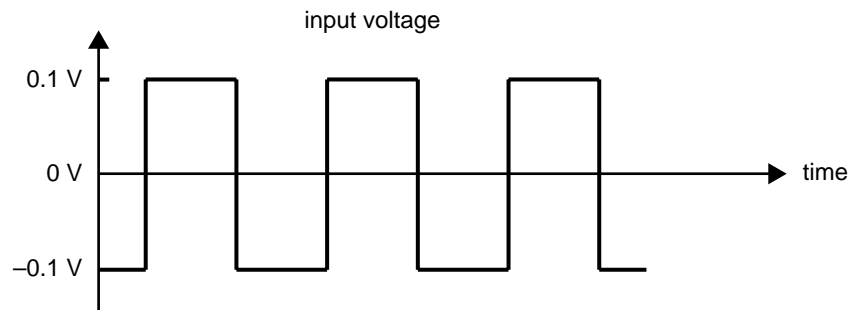
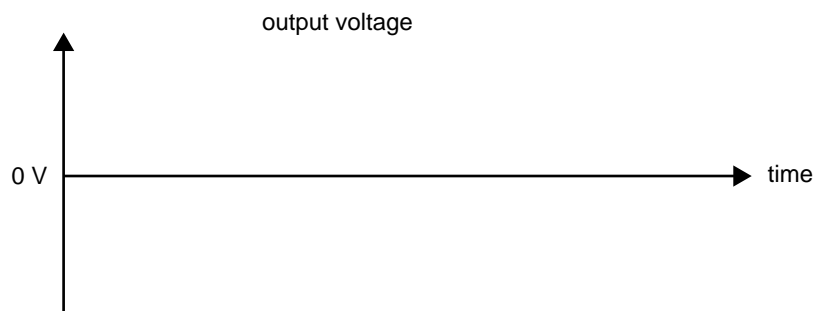
**Figure 9a****Figure 9b**

2 marks

# PHYSICS

## Written examination 1

### FORMULA SHEET

#### Directions to students

Detach this formula sheet.

This formula sheet is provided for your reference.

## Formulas

### Area 1 – Sound

speed, frequency and wavelength

$$v = f \lambda$$

intensity and levels

$$\text{sound intensity level (in dB)} = 10 \log_{10} \left( \frac{I}{I_0} \right)$$

$$\text{where } I_0 = 1.0 \times 10^{-12} \text{ W m}^{-2}$$

standing waves

$$\text{nodal separation} = \frac{\lambda}{2}$$

transmission of sound

$$\text{intensity} \propto \frac{1}{r^2}$$

(when sound spreads out uniformly in all directions)

### Area 2 – Electric power

magnetic force

$$F = I l B$$

electromagnetic induction

$$\text{emf: } \mathcal{E} = -N \frac{\Delta \Phi}{\Delta t}$$

$$\text{flux: } \Phi = BA$$

transformer action

$$\frac{V_1}{V_2} = \frac{N_1}{N_2}$$

AC voltage and current

$$V_{\text{RMS}} = \frac{1}{\sqrt{2}} V_{\text{peak}}$$

$$I_{\text{RMS}} = \frac{1}{\sqrt{2}} I_{\text{peak}}$$

voltage; power

$$V = RI$$

$$P = VI$$

### Area 3 – Electronic systems

resistors in series

$$R_T = R_1 + R_2$$

resistors in parallel

$$\frac{1}{R_T} = \frac{1}{R_1} + \frac{1}{R_2}$$

AC voltage and current

$$V_{\text{RMS}} = \frac{1}{\sqrt{2}} V_{\text{peak}}$$

$$I_{\text{RMS}} = \frac{1}{\sqrt{2}} I_{\text{peak}}$$

capacitors

$$\text{time constant : } \tau = RC$$

AND gate

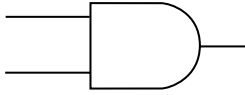

Input A	Input B	Output
0	0	0
0	1	0
1	0	0
1	1	1

NAND gate

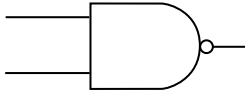

Input A	Input B	Output
0	0	1
0	1	1
1	0	1
1	1	0

OR gate

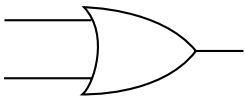

Input A	Input B	Output
0	0	0
0	1	1
1	0	1
1	1	1

NOR gate

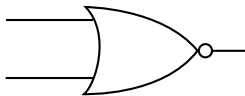

Input A	Input B	Output
0	0	1
0	1	0
1	0	0
1	1	0

NOT gate

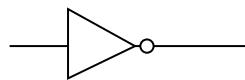

Input	Output
0	1
1	0

**Prefixes for SI units**

Prefix	Abbreviation	Value
giga	G	$10^9$
mega	M	$10^6$
kilo	k	$10^3$
milli	m	$10^{-3}$
micro	$\mu$	$10^{-6}$
nano	n	$10^{-9}$

**END OF FORMULA SHEET**