



**Victorian Certificate of Education
2004**

SUPERVISOR TO ATTACH PROCESSING LABEL HERE

STUDENT NUMBER

Letter

Figures										
Words										

PHYSICS
Written examination 1

Monday 7 June 2004

Reading time: 11.45 am to 12.00 noon (15 minutes)

Writing time: 12.00 noon to 1.30 pm (1 hour 30 minutes)

QUESTION AND ANSWER BOOK

Structure of book

<i>Area</i>	<i>Number of questions</i>	<i>Number of questions to be answered</i>	<i>Number of marks</i>	<i>Suggested times (minutes)</i>
1. Sound	12	12	30	30
2. Electric power	14	14	30	30
3. Electronic systems	13	13	30	30
			Total 90	90

- Students are permitted to bring into the examination room: pens, pencils, highlighters, erasers, sharpeners, rulers, up to two pages (one A4 sheet) of pre-written notes (typed or handwritten) and an approved graphics calculator (memory cleared) and/or one scientific calculator.
- Students are NOT permitted to bring into the examination room: blank sheets of paper and/or white out liquid/tape.

Materials supplied

- Question and answer book of 25 pages, with a detachable formula sheet in the centrefold.

Instructions

- Detach the formula sheet from the centre of this book during reading time.
- Write your **student number** in the space provided above on this page.
- Answer all questions in this question and answer book where indicated.
- **Always show your working** where space is provided.
- Where an answer box has a unit printed in it, give your answer in that unit.
- All written responses must be in English.

Students are NOT permitted to bring mobile phones and/or any other electronic communication devices into the examination room.

Area 1 – Sound

Throughout the questions on sound, take the speed of sound in air to be 340 m s^{-1} .

Ryan and Lee are investigating some properties of sound, and sound systems. They have been given a signal generator that provides frequencies in the audible range, a small loudspeaker, and an oscilloscope that they use to observe the amplitude of the signal from a microphone (Figure 1).

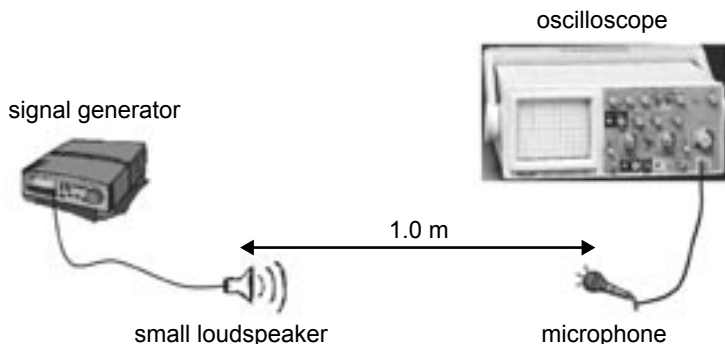

Figure 1

They first adjust the signal generator so that sound is emitted from the loudspeaker. Figure 2 shows the oscilloscope trace of the signal from the microphone.

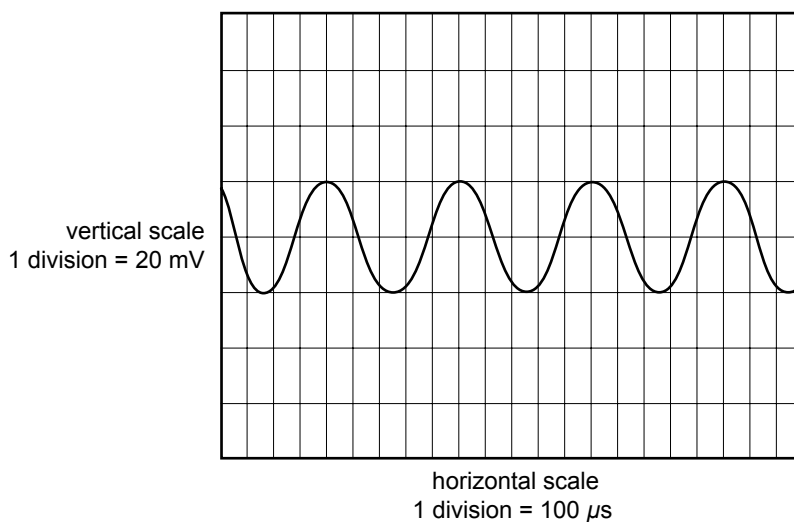

Figure 2

Question 1

What is the frequency of the signal from the microphone?

Hz

2 marks

When the microphone is 1.0 m from the loudspeaker, the sound intensity at the microphone is 100 mW m^{-2} . Ryan then moves the microphone further from the loudspeaker so that the distance separating them is 2.0 m.

Question 2

What is the expected sound intensity at this position?

mW m^{-2}

2 marks

Question 3

By how many dB has the sound level decreased at a distance of 2.0 m from the loudspeaker compared with the level at a distance of 1.0 m from the loudspeaker?

dB

3 marks

Ryan and Lee decide to study the effect of different frequencies on the intensity of the sound produced by the loudspeaker. Figure 3 below shows the response of the speaker as a function of frequency, when supplied with the same power.

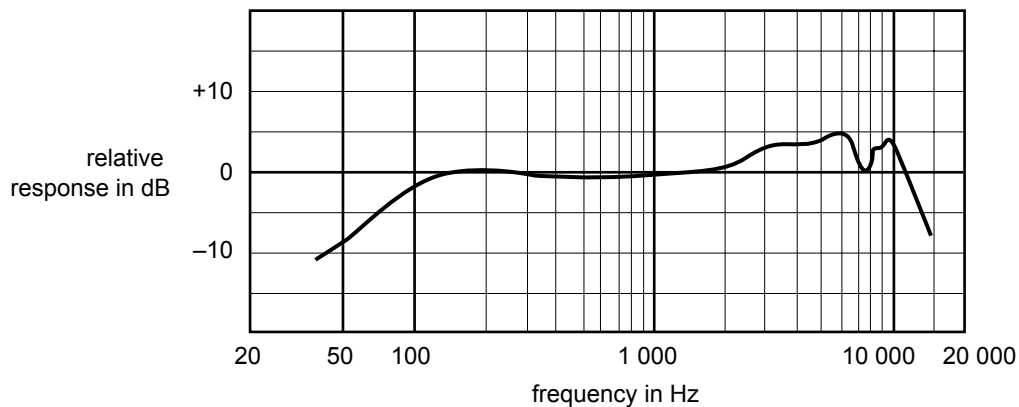

Figure 3

The sound intensity at 1000 Hz at a distance of 1.0 m was measured to be 100 mW m^{-2} .

They adjust the signal generator to a frequency of 6000 Hz, and provide the same power into the loudspeaker as they did for the 1000 Hz measurement.

Question 4

What is the sound intensity they measure at the microphone 1.0 m away?

mW m^{-2}

2 marks

Ryan and Lee now use their equipment to study interference effects. They set the signal generator to a frequency of about 1000 Hz, and connect it to an amplifier that feeds two identical small loudspeakers in phase. The loudspeakers are placed 4.0 m apart. The setup is shown in Figure 4 below. A line OP is drawn on the floor from the midpoint of the line joining the loudspeakers and perpendicular to that line. Another line XY is drawn parallel to, and about 3.0 m from, the line joining the loudspeakers.

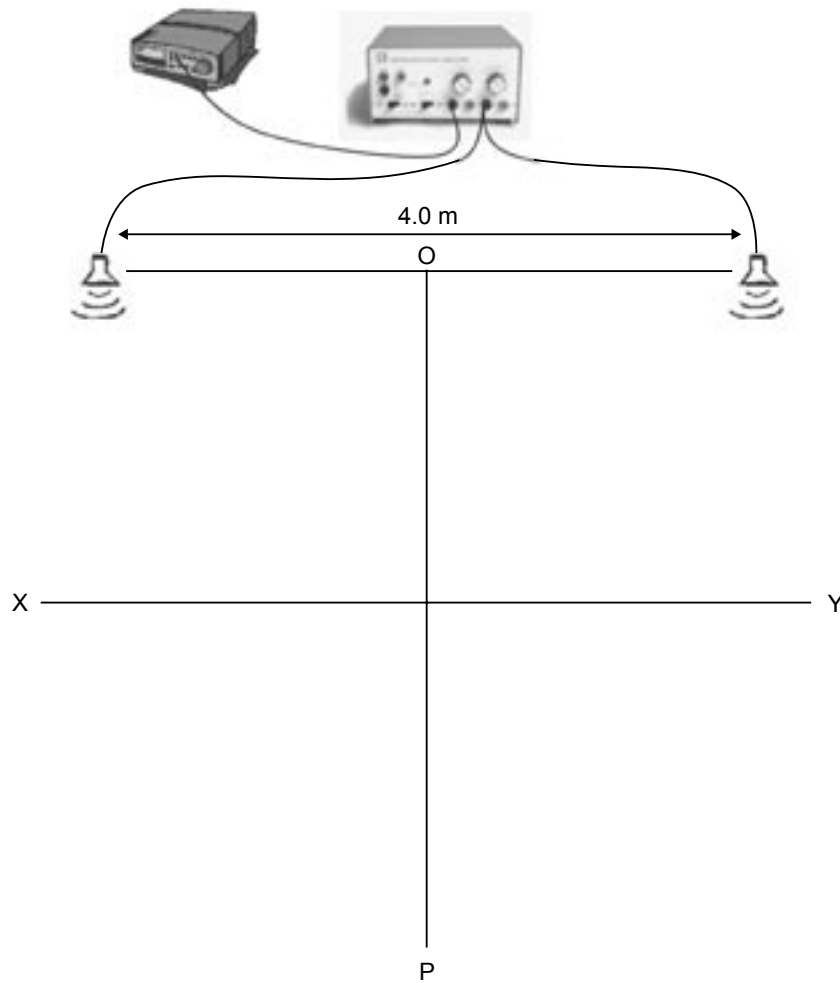

Figure 4

Lee takes the microphone, which is still connected to the oscilloscope, and walks slowly from point O towards point P. Ryan records the amplitude of the signal on the oscilloscope for different positions of the microphone that Lee is holding.

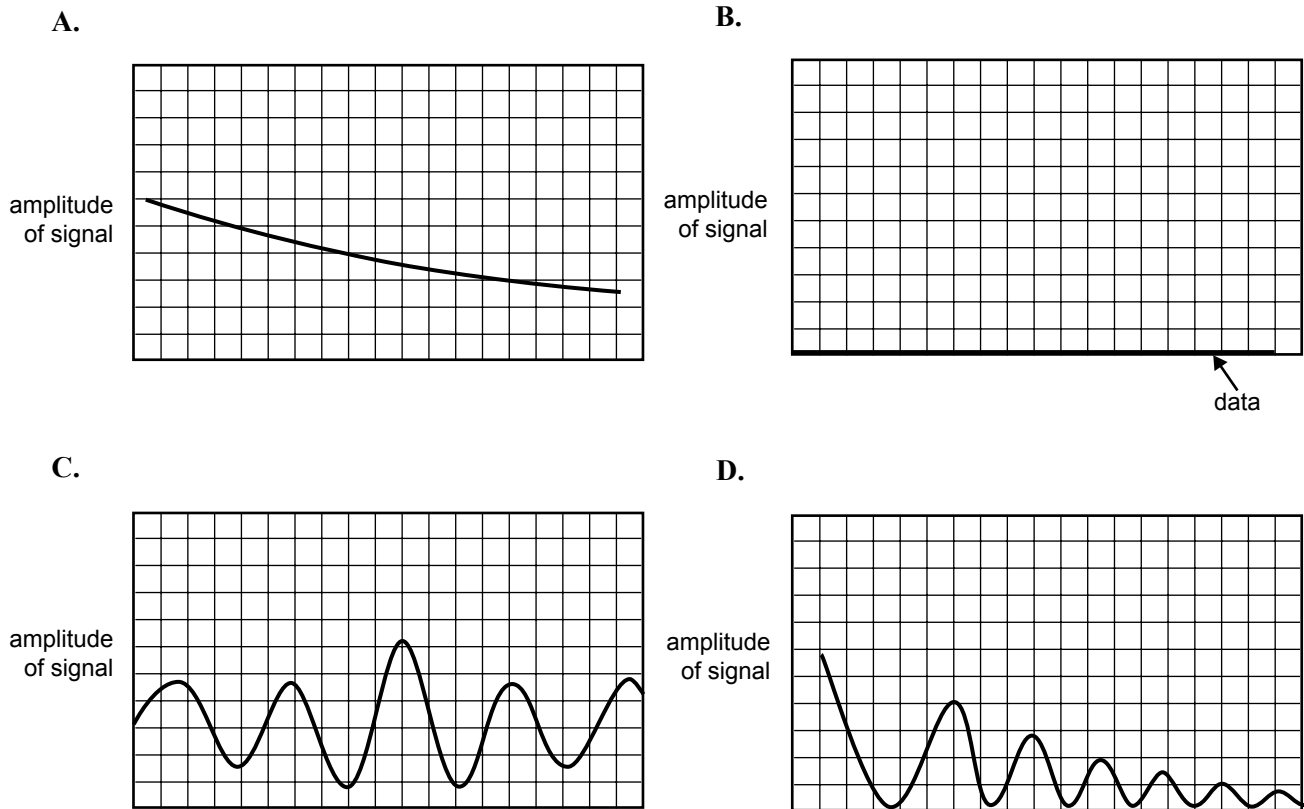

Figure 5

Question 5

Which of the diagrams (A.–D.) shown in Figure 5 best shows the variation of amplitude as Lee moves from position O towards position P? In the space below justify your choice.

3 marks

They then measure the variation of the amplitude as Lee walks from point X to point Y.

Question 6

Which of the diagrams (A.–D.) shown in Figure 5 best shows the variation of amplitude as Lee moves from position X towards position Y? In the space below justify your choice.

3 marks

Ryan and Lee now feel quite confident that they understand the wave-nature of sound. Ryan suggests that they do an experiment on the diffraction of sound. They decide to set up a single loudspeaker behind a wall with a 0.30 m gap in it, as shown in Figure 6. They then intend to measure the amplitude of sound with the microphone and oscilloscope as before, as Lee walks along the line QR.

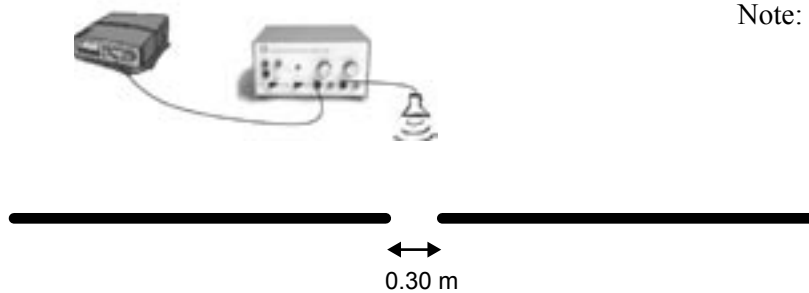

Note: Figure is approximately to scale

Q ————— R

Figure 6

Lee thinks this is a waste of time since the gap will just let through a ‘beam’ of sound, with sharply defined limits, like the grey curve in the graph below (Figure 7). Ryan, however, believes that this is not true, and they adjust the frequency generator and make the measurement. The result is shown below as the dashed line in Figure 7.

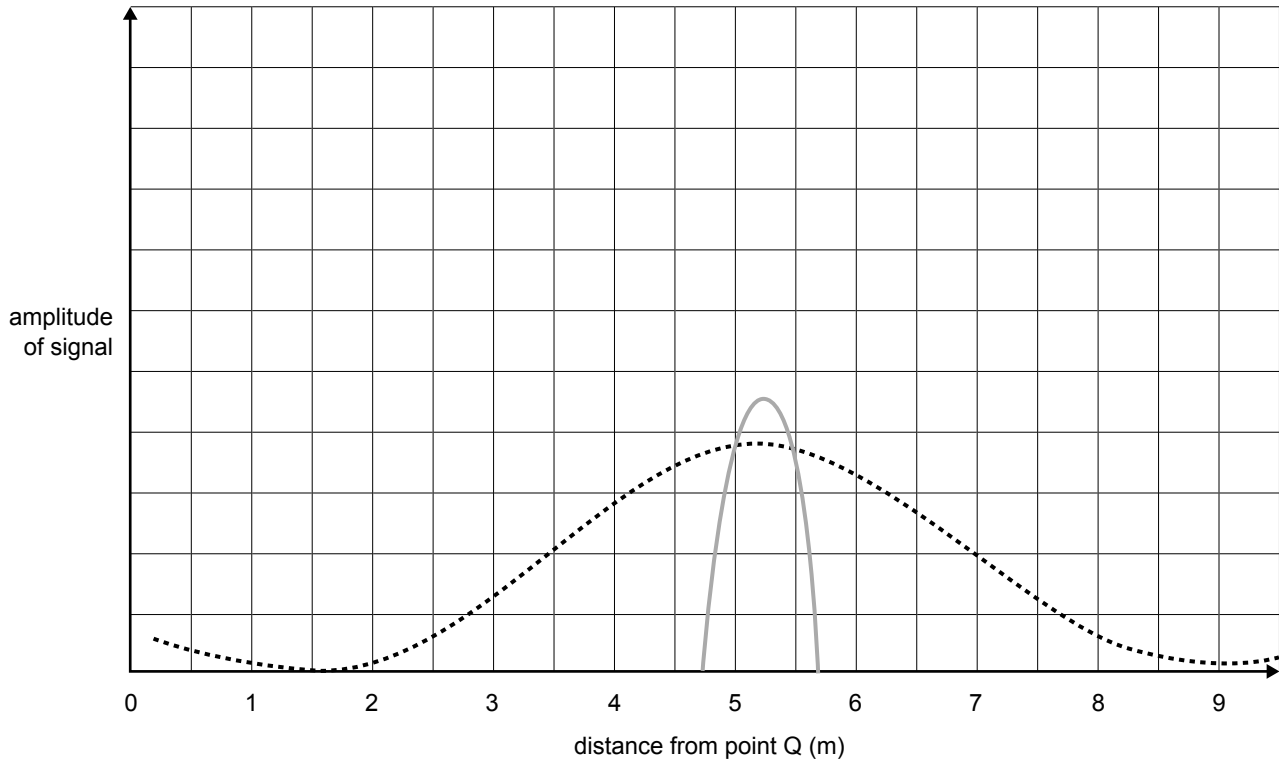

Figure 7

Question 7

In the space below, explain why Ryan and Lee obtained the result shown as the dashed curve in Figure 7. You should mention the relevance of the size of the gap in the wall, and the approximate frequency (not stated in the description above) that they must have used. Write this frequency in the box provided.

	Hz
--	----

4 marks

Question 8

For which of the frequencies listed below (**A.–D.**) would Lee's prediction (the grey curve in Figure 7) be nearly correct?

- A. 10 000 Hz
- B. 1 000 Hz
- C. 100 Hz
- D. 10 Hz

2 marks

A group of students is listening to loud techno music. When each heavy bass beat occurs, they observe that the speaker cone moves back and forth by about one centimetre, as indicated in Figure 8.

The students consider the implications of this observation with regard to the nature of sound waves.

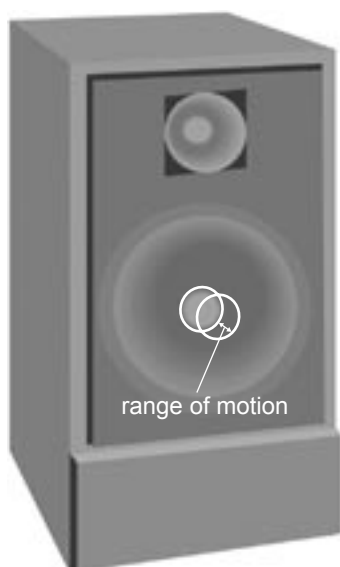
**Figure 8****Question 9**

In the box provided, write the name of the student whose statement best relates the observation to the nature of sound waves in air.

Jess says the motion would lead to a longitudinal wave, with compressions and rarefactions in the air moving back and forth in front of the speaker with the speed of sound.

Chris says the motion would lead to a longitudinal wave, with compressions and rarefactions in the air moving radially away from the speaker with the speed of sound.

Robin says the motion implies that sound is a transverse wave, where the air in front of the speaker is moving up and down with the speed of sound.

Hilary agrees with Robin that the motion implies that sound is a transverse wave, except that the air particles are moving away from the speaker with the speed of sound.

2 marks

Kim has set up five plastic pipes (A–E) on the window sill, pointing out into the open air as shown in Figure 9. The tubes are all **open at both ends**, but have different lengths from L to $\frac{1}{4}L$, as shown in the diagram. The interesting thing about such pipes is that each selects out from all the noise in the surroundings, a resonant frequency that depends on its length.

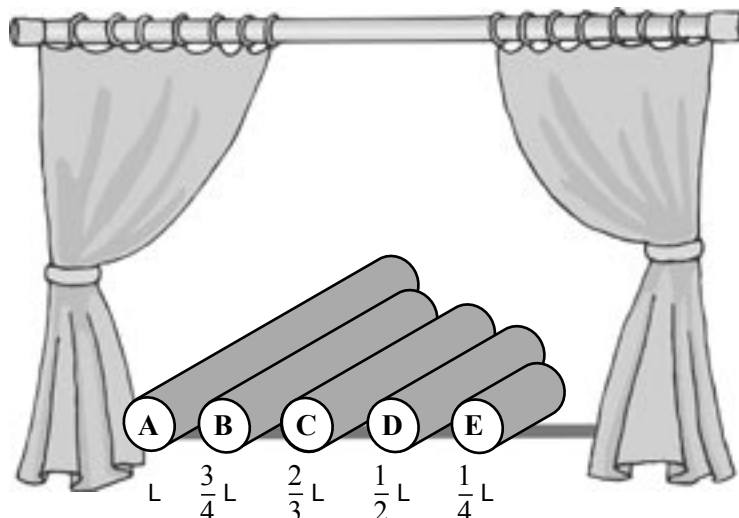

Figure 9

When Kim listens at pipe A, of length L , the loudest sound that is heard has a frequency of 510 Hz.

Question 10

What is the length of pipe A?

 m

3 marks

Question 11

At which tube (A–E in Figure 9) will Kim hear sound of frequency 765 Hz?

2 marks

Kim now seals the end of each tube that is outside the window with a sheet of thick cardboard. Kim then holds a tuning fork of frequency 510 Hz in front of each tube in turn.

Question 12

Which tube (A–E in Figure 9) will resonate at a frequency of 510 Hz?

2 marks

END OF AREA 1
TURN OVER

AREA 2 – Electric power

As a decoration for a party, Val purchased a set of 36 identical small, coloured globes connected in three strings each with 12 globes, as shown in Figure 1. The globes are designed to use the household 240 V_{RMS} supply.

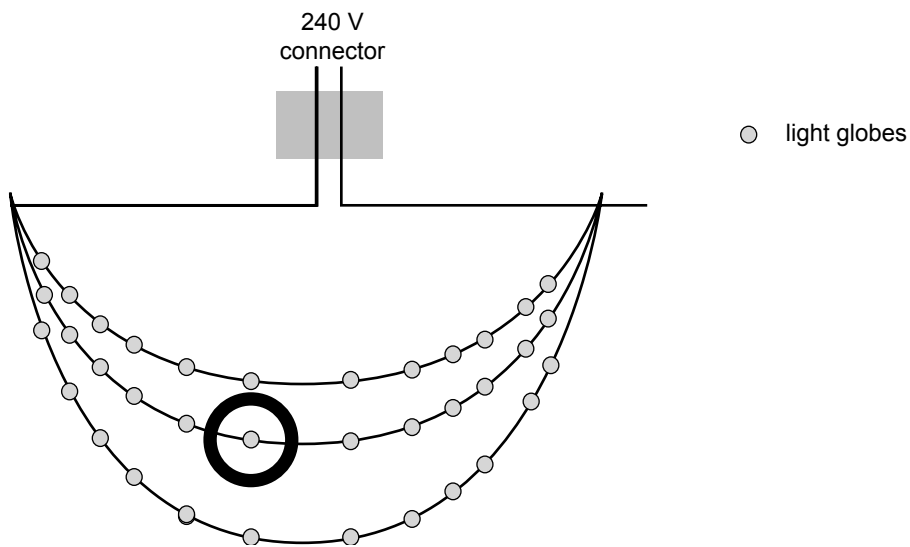

Figure 1

The claim on the box said that the power used when all the globes were lit was 48 W.

Question 1

What RMS current is drawn from the mains supply when all the globes are lit?

A

2 marks

Question 2

What current is flowing through **the globe with the circle round it**, when all the globes are lit?

A

2 marks

Question 3

What is the RMS voltage across each globe?

2 marks

Question 4

What is the power rating of each globe?

2 marks

On the box it stated that if one globe burnt out, the rest would continue to light. To Val, as a VCE physics student, this seemed strange. So as a test of this statement, Val removed the circled globe.

Question 5

Which of the statements below best describes the situation with the globe removed?

- A. All the globes (except the one that is removed) remain lit.
- B. The middle string does not light but the other two strings light as before.
- C. The middle string does not light but the other two strings do, and are brighter than before.
- D. None of the globes is lit.

2 marks

Reg runs a farm in central Victoria, and has a powerful electric welder which operates from the 240 V AC household supply. When operating, the welder draws a current of 80 A. This large current is a problem since the electricity supply comes to the workshop from the farmhouse, which is 400 m away. The two cables that run from the farmhouse to the workshop have a total resistance of 0.32 ohm. This means that because of the voltage drop in the wires, the voltage at the workshop is less than 240 V, and the welder will not operate properly.

Tania, his daughter, a VCE student, knows that in electric power transmission over long distances it is best to use high voltages.

Question 6

Which **two** of the following statements are relevant to explaining the reason why high voltages should be used?

- A. High transmission voltages require high current.
- B. For a given power the larger the transmission voltage the smaller the current.
- C. High transmission voltage causes less radiation of electric energy.
- D. To minimise power loss in the wires the current must be small.

2 marks

Tania realises that the problem can be solved by using transformers: one to step the voltage up at the house, and another to step the voltage down again at the workshop. The circuit is shown in Figure 2.

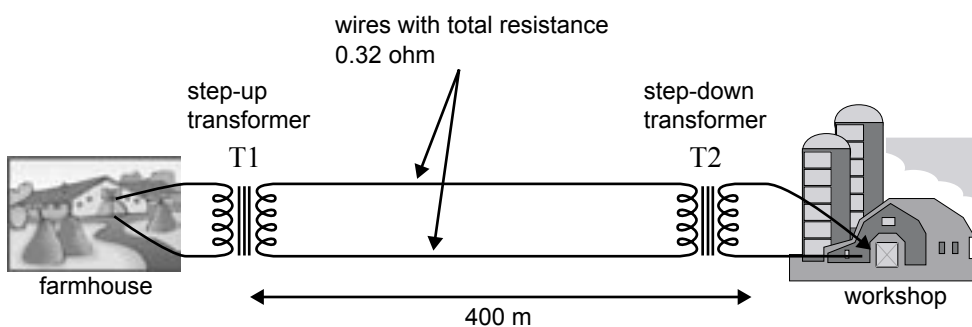

Figure 2

In the following questions you can ignore the short connections to the transformers from the house and workshop.

After installing the system, the voltage at the workshop was 240 V when the welder was drawing the required 80 A. The current flowing through the wires joining T1 and T2 was 5.0 A.

The turns-ratio of transformer T2 is defined as $\frac{\text{number of turns on secondary of transformer T2}}{\text{number of turns on primary of transformer T2}}$.

Question 7

What is the value of this ratio?

2 marks

Question 8

What is the value of the voltage drop across the wires joining the two transformers?

2 marks

Mary and Shin have constructed a simple alternator. It consists of a single rectangular coil of wire, $0.40 \text{ m} \times 0.30 \text{ m}$, which is connected to slip rings, as shown in Figure 3. The coil is in a uniform magnetic field of 0.12 T , and can be turned in the direction as shown in Figure 3.

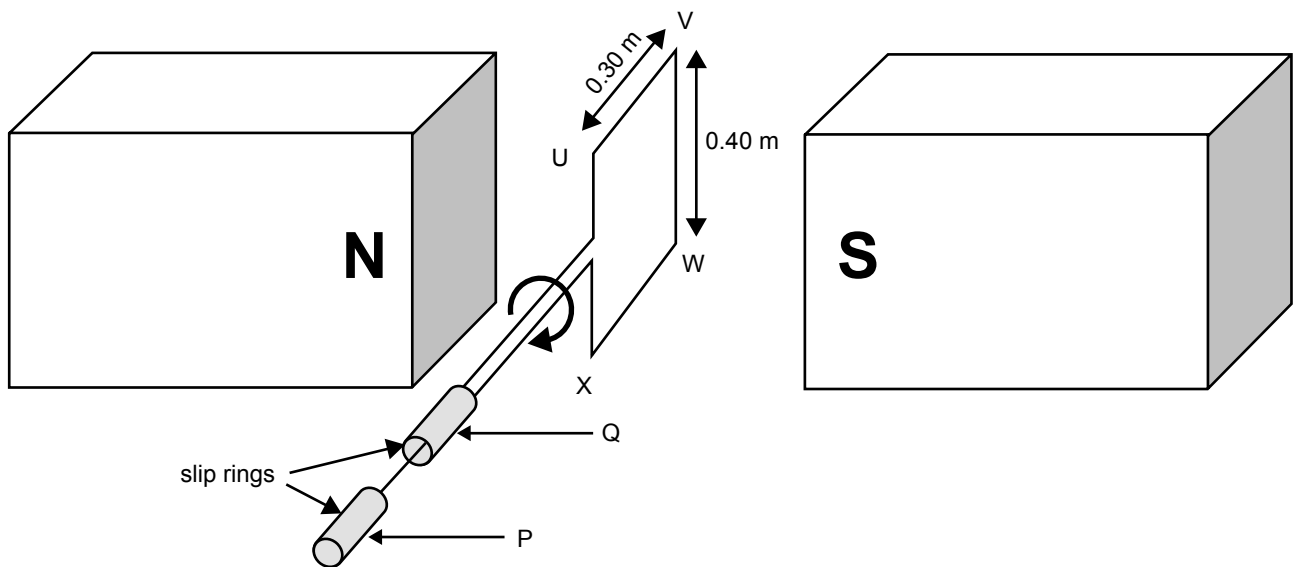
**Figure 3****Question 9**

What is the magnitude of the flux through the coil when oriented as in Figure 3?

2 marks

As a test, Shin rotates the coil at a constant rate in a time of 0.15 s through an angle of 90° from the orientation shown in Figure 3. Mary observes the voltage on an oscilloscope.

Question 10

Which of the graphs below best represents the variation as a function of time of the voltage at point Q relative to point P (V_{QP})?

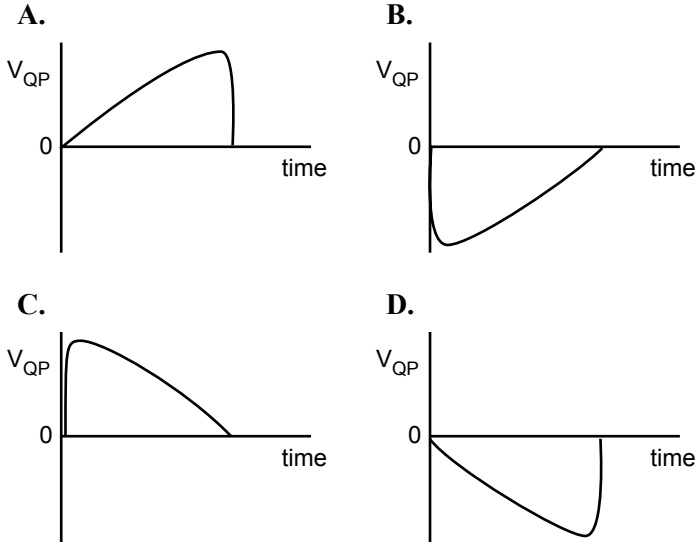

2 marks

Question 11

What is the average voltage measured between points Q and P due to this rotation?

2 marks

Mary now rotates the coil at a constant rate of 5 revolutions per second, and the students observe that the voltage between points Q and P varies with time as shown in Figure 4 below.

Shin decides to test the effect of rotation speed, and turns the coil at a rate of 10 revolutions per second.

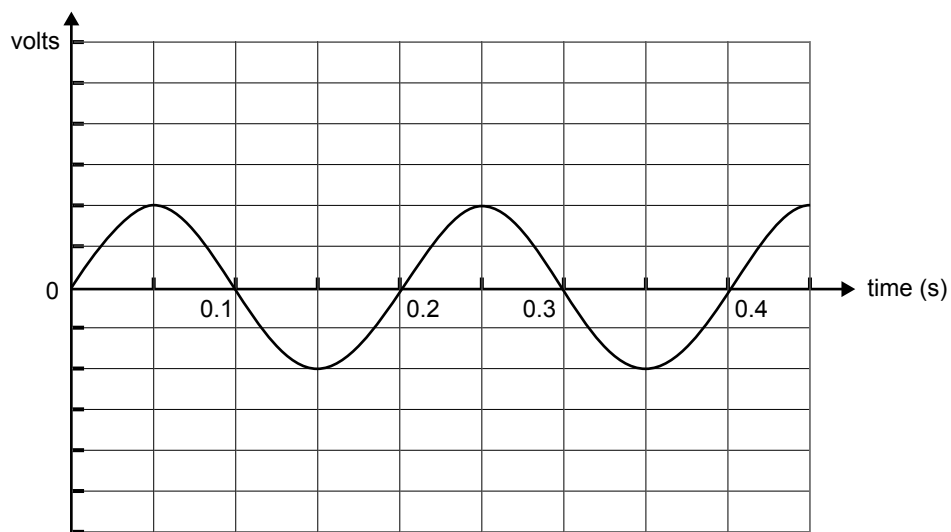

Figure 4

Question 12

On Figure 4 above, sketch a graph that shows the variation with time of the voltage between points Q and P that the students would now see.

3 marks

A cut-away picture of a loudspeaker is shown in Figure 5. It basically consists of a coil of wire that is attached to a paper cone, and placed in a strong radial magnetic field. In a sound system this coil would be supplied with an alternating current from an audio amplifier. The section view of the unit (Figure 6) shows the direction of the magnetic field relative to the coil more clearly.

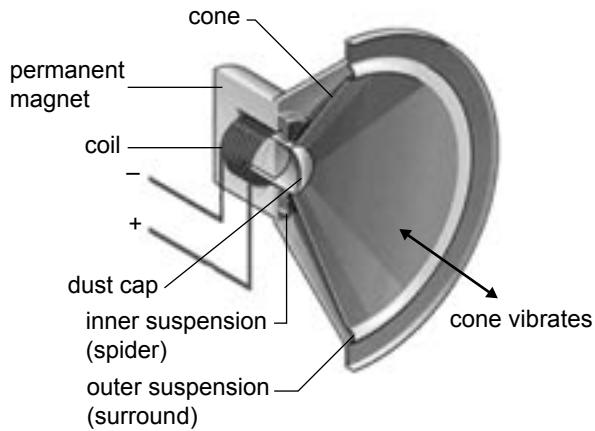

Figure 5

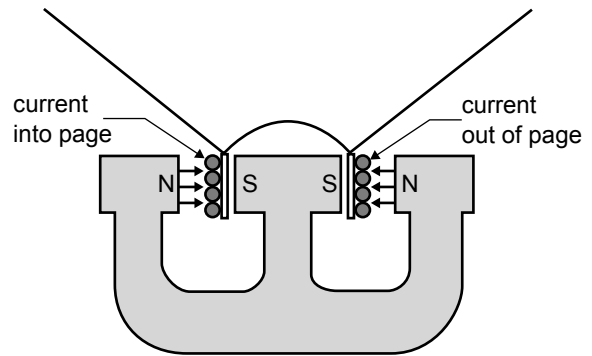

Figure 6

Question 13

When the current in the coil is flowing into the page on the left side of the coil (as in Figure 6), which of the statements below gives the direction of motion of the coil (and the attached cone)?

- A. It will move up the page.
- B. It will move down the page.
- C. It will rotate clockwise (viewed from in front of the loudspeaker core).
- D. It will rotate anticlockwise (viewed from in front of the loudspeaker core).

2 marks

The diameter of the coil is 0.04 m, and consists of 200 turns of wire. The uniform radial magnetic field through the coil is 0.4 T.

Question 14

What is the magnitude of the force on the coil when a current of 0.5 A is flowing?

N

3 marks

AREA 3 – Electronic systems

You are a VCE student studying how a light emitting diode (LED) works. The basis of your LED circuit will be a voltage divider. Your starting point, following advice from your teacher, is to wire the DC voltage divider circuit shown in Figure 1, where $V_{IN} = 30\text{ V}$.

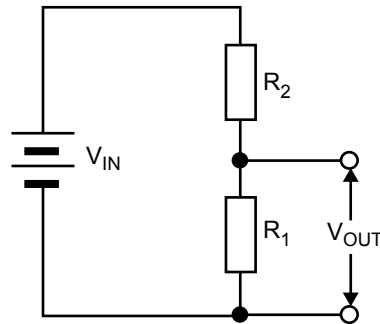

Figure 1

Question 1

In Figure 1, if $R_1 = 5\text{ k}\Omega$ what is the value of the resistance R_2 that is required to get $V_{OUT} = 6\text{ V}$? Show your working and express your answer for R_2 in $\text{k}\Omega$.

$\text{k}\Omega$

2 marks

Question 2

You wire up the circuit of Figure 1 but only have $10\text{ k}\Omega$ resistors available. Explain how you construct the $R_1 = 5\text{ k}\Omega$ resistor using only $10\text{ k}\Omega$ resistors, and include a **sketch** to show the connections between the appropriate number of $10\text{ k}\Omega$ resistors.

2 marks

You modify the circuit of Figure 1, and replace resistor R_1 by a $220 \mu\text{F}$ capacitor, C . The new circuit is shown in Figure 2, where $R_2 = 1.0 \text{ k}\Omega$.

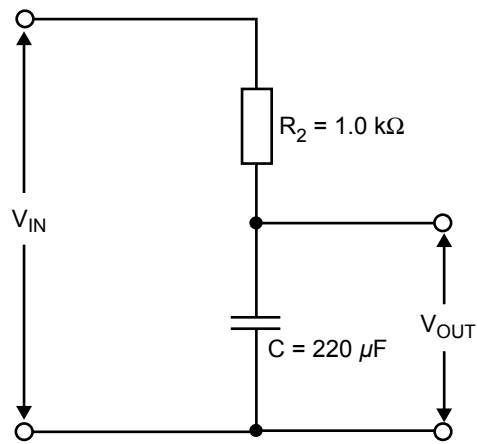

Figure 2

Question 3

What is the time constant for the circuit of Figure 2? Show your working and provide the answer in units of seconds.

s

2 marks

You study the effect of this circuit for the time varying input voltage, V_{IN} , shown in Figure 3. This input voltage is 0 for all time up to $t = 1.0$ s.

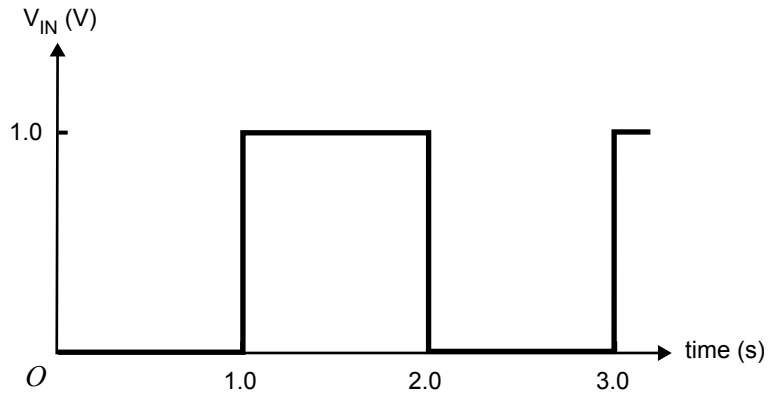
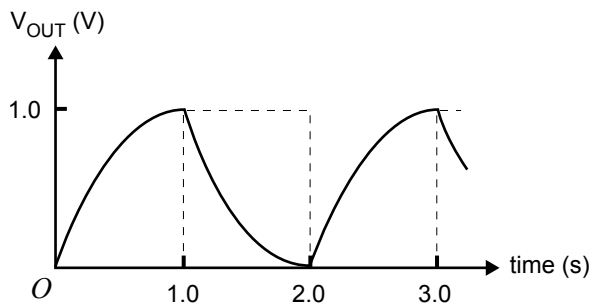

Figure 3

Question 4

Which one of the sketches (A.–D.) in Figure 4 correctly shows the voltage (V_{OUT}) across the capacitor, C, in Figure 2? The dotted lines in Figure 4 represent the input voltage, V_{IN} , from Figure 3.

A.



B.

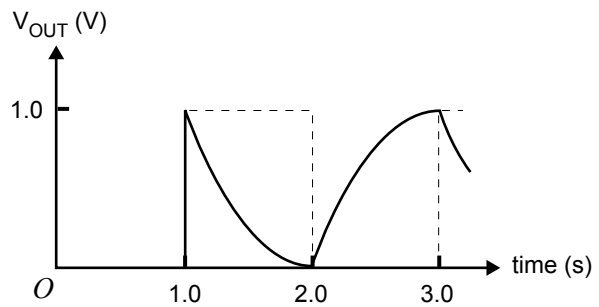

C.

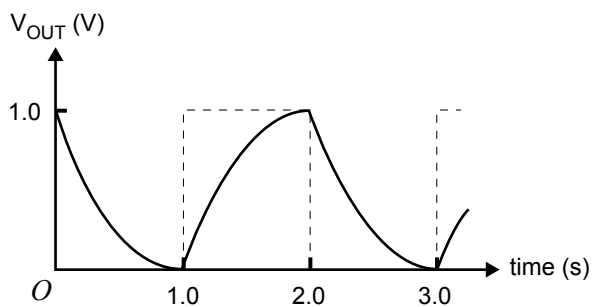

D.

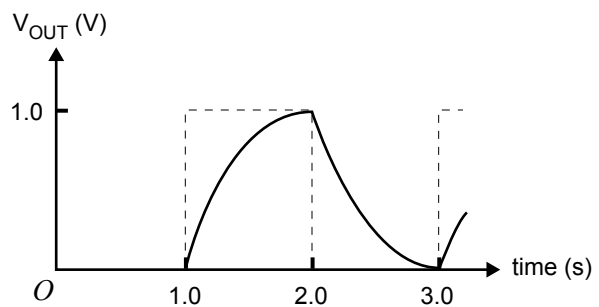

Figure 4



2 marks

You modify your original voltage divider circuit (Figure 1, page 17) to produce the LED circuit shown in Figure 6a. The LED current-voltage characteristics are also provided (Figure 6b). You observe that the light output increases as the forward current, I_F , through the LED increases, and adjust the resistance, R_D , so that the forward current through the LED is $I_F = 10 \text{ mA}$.

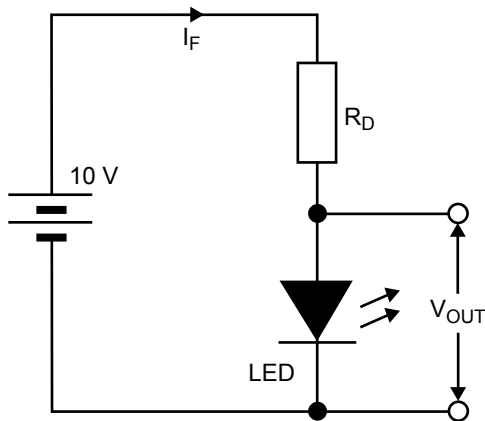

Figure 6a

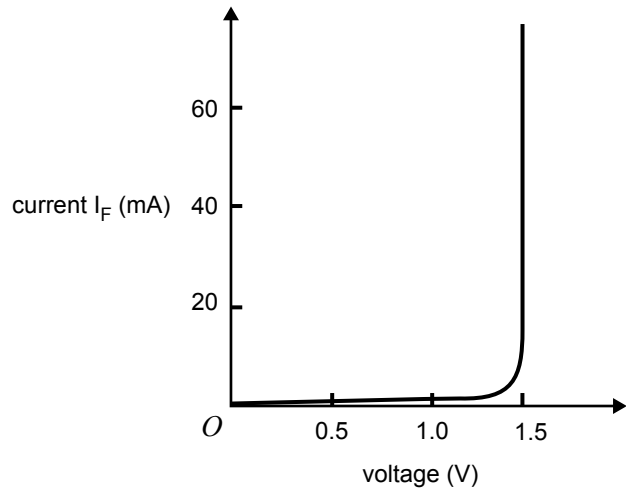

Figure 6b

Question 7

Using the information in Figures 6a and 6b, what is the value of the resistance, R_D , that will ensure the forward current is $I_F = 10 \text{ mA}$? Express your answer in Ω .

Ω

2 marks

Question 8

Explain what will happen to the LED light-output if the value of R_D is slightly lower than the value you have calculated in Question 7.

2 marks

You arrange the LED light-output to vary with time, and detect this using the voltage across a light-dependent resistor. However, this voltage is small and needs to be amplified. Your teacher suggests that you use a linear amplifier.

Question 9

Explain in words what is meant by the term **linear** in the context of the amplifier.

2 marks

Question 10

On the set of axes provided in Figure 7, sketch a graph of the output voltage, V_{OUT} , as a function of the input voltage V_{IN} . The axes of the graph must be clearly labelled.

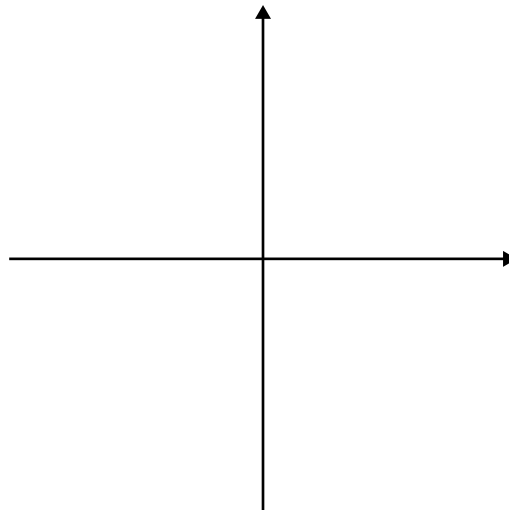
**Figure 7**

2 marks

A friend of yours has a wine collection and asks you to help design a way of keeping a record of the collection using the bar codes printed on the wine bottle labels. Each wine type has a unique bar code. Your teacher shows you how to combine the LED circuit and detector circuit to form a bar code reader and you design the necessary digital electronics.

A typical bar code is shown in Figure 8a. It is essentially a set of white and black bands that can be represented by binary states: white = 0 and black = 1. To simplify this problem you may assume that there are only 4 bands in the bar code. An example, and the associated binary code (1010), when read by a bar code reader, is shown in Figure 8b.



Figure 8a

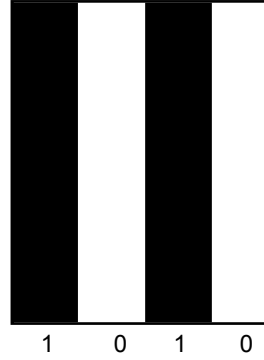

Figure 8b

Question 11

Your friend decides to have a different bar code for each type of wine. What is the maximum number of wine types that they can have in their collection?

Explain your answer.

Number of wine types =

2 marks

To identify a bottle as it is added or removed from the wine collection, you design a system where the code read from the wine bottle is compared to codes stored in a computer memory. Each bit of the bottle bar code is compared to the appropriate bit of the stored codes till a match is found. Each bit comparison produces a 1 if the bits match and a 0 if they do not.

Question 12

Which one of the following truth tables correctly provides this output? In the top row of these truth tables, B represents the bottle bar-code bit, C the stored computer code bit and O the output bit.

A.

B	C	O
0	0	1
0	1	0
1	0	0
1	1	0

B.

B	C	O
0	0	1
0	1	0
1	0	0
1	1	1

C.

B	C	O
0	0	0
0	1	1
1	0	1
1	1	0

D.

B	C	O
0	0	0
0	1	0
1	0	0
1	1	1

2 marks

In addition to identifying the wine type, you suggest a circuit that will count the bottles. This counting circuit uses three JK flip-flops (JKFF) as shown in Figure 9. The input to the first JKFF is also shown when a new wine bottle is identified to be counted. It is the input change on the edge numbers $1 \rightarrow 0$, that causes a change to the output, Q , of the JKFF.

There are initially 3 bottles, and this is indicated by the JKFF outputs, Q , in Figure 9. Note that the JKFF outputs are read in reverse order as indicated.

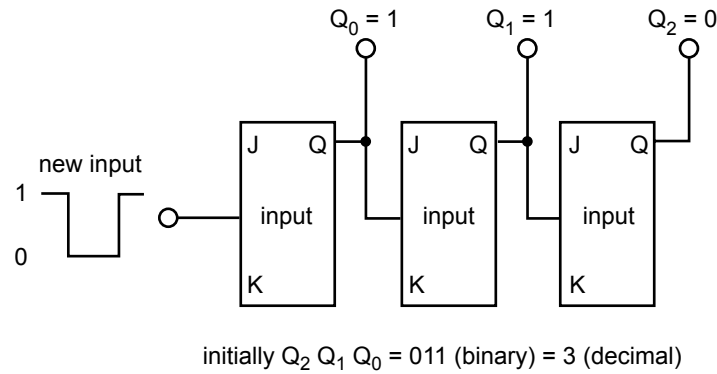

Figure 9

Question 13

By completing the timing diagram below (Figure 10), show how the outputs of the JKFFs change to indicate there is a new total of 4 bottles.

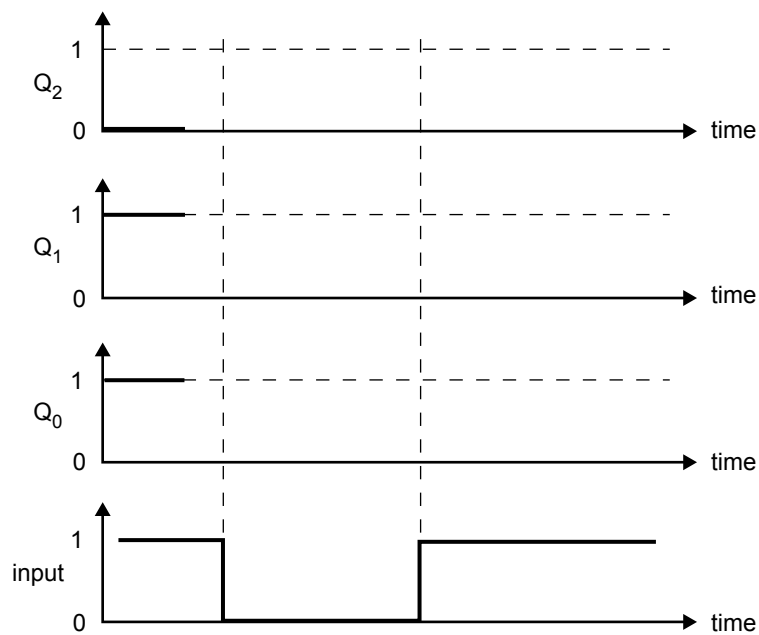

Figure 10

3 marks