



**Victorian Certificate of Education
2007**

SUPERVISOR TO ATTACH PROCESSING LABEL HERE

STUDENT NUMBER

Letter

Figures									
Words									

SYSTEMS ENGINEERING
Written examination

Friday 16 November 2007

Reading time: 9.00 am to 9.15 am (15 minutes)

Writing time: 9.15 am to 10.45 am (1 hour 30 minutes)

QUESTION AND ANSWER BOOK

Structure of book

<i>Section</i>	<i>Number of questions</i>	<i>Number of questions to be answered</i>	<i>Number of marks</i>
A	20	20	20
B	26	26	70
			Total 90

- Students are permitted to bring into the examination room: pens, pencils, highlighters, erasers, sharpeners, rulers, one scientific calculator.
- Students are NOT permitted to bring into the examination room: blank sheets of paper and/or white out liquid/tape.

Materials supplied

- Question and answer book of 24 pages including formulas on page 24.
- Answer sheet for multiple-choice questions.

Instructions

- Write your **student number** in the space provided above on this page.
- Check that your **name** and **student number** as printed on your answer sheet for multiple-choice questions are correct, **and** sign your name in the space provided to verify this.
- All calculations must show appropriate formulas and working.
- All written responses must be in English.

At the end of the examination

- Place the answer sheet for multiple-choice questions inside the front cover of this book.

Students are NOT permitted to bring mobile phones and/or any other unauthorised electronic devices into the examination room.

SECTION A – Multiple-choice questions

Instructions for Section A

Answer **all** questions in pencil on the answer sheet provided for multiple-choice questions.

Choose the response that is **correct** for the question.

A correct answer scores 1, an incorrect answer scores 0.

Marks will **not** be deducted for incorrect answers.

No marks will be given if more than one answer is completed for any question.

A formula sheet is provided on page 24.

Question 1

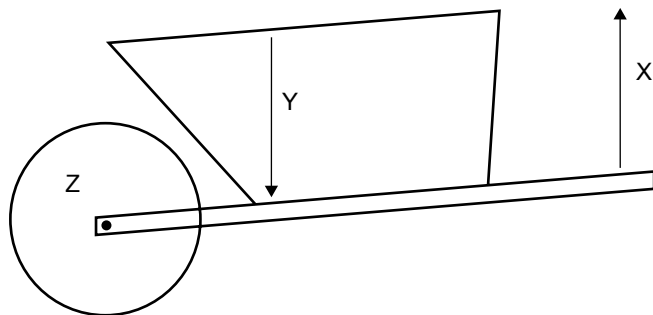

On the wheel barrow, which of the answers shows the correct position of the effort, load and fulcrum?

- | | X | Y | Z |
|----|---------|--------|---------|
| A. | fulcrum | load | effort |
| B. | effort | load | fulcrum |
| C. | fulcrum | effort | load |
| D. | load | effort | fulcrum |

Question 2

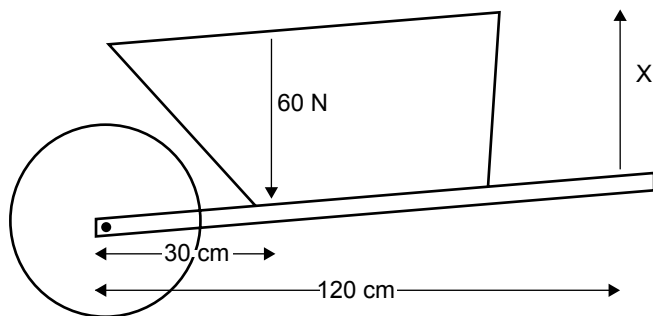

What newton force is exerted on the handle to lift the load?

- A. 1800 N
- B. 180 N
- C. 20 N
- D. 15 N

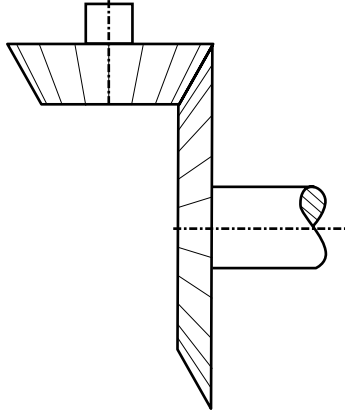
Question 3

The gears above are best described as

- A. worm gears.
- B. crown gears.
- C. rack and pinion gears.
- D. bevel gears.

Question 4

The diagram below shows 4 gears. Gears B and C are connected.

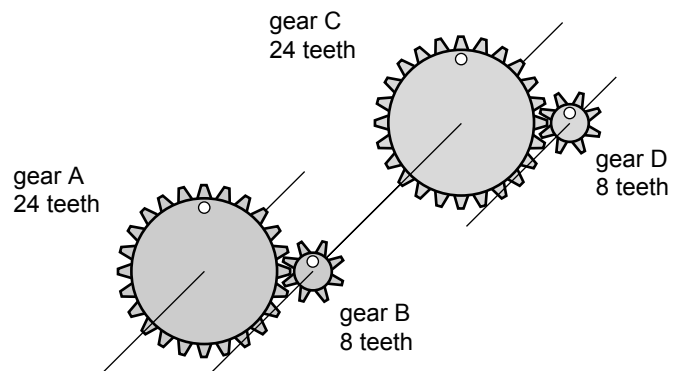

If gear A rotates at 45 rpm, gear D will rotate at

- A. 405 rpm.
- B. 135 rpm.
- C. 15 rpm.
- D. 5 rpm.

Question 5

Below is a diagram of a pedal.

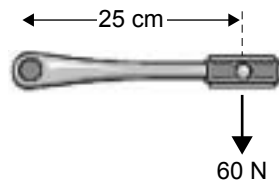

What is the moment of the force acting on the pedal?

- A. 15 Nm
- B. 35 Nm
- C. 85 Nm
- D. 1500 Nm

Question 6

The diagram below shows a hydraulic system using two connected cylinders.

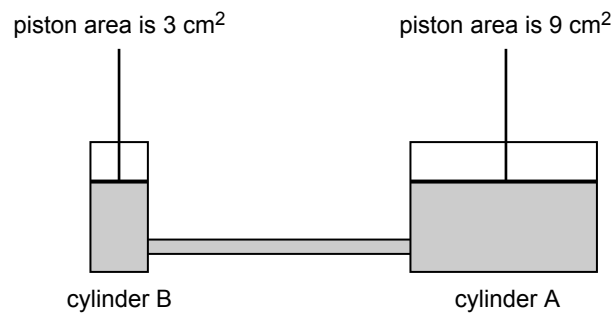

A 9 newton force is applied **down** on cylinder A.

What is the force **up** on cylinder B?

- A. 3 N
- B. 18 N
- C. 27 N
- D. 8 N

Use the following information to answer Questions 7–8.

Below is an illustration of a four-stroke engine.

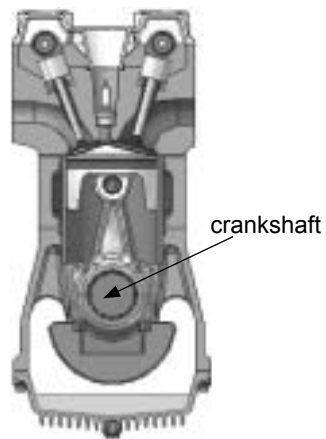

Question 7

Which one of the following types of motion best describes the motion of the crankshaft in the engine?

- A. linear
- B. rotary
- C. reciprocating
- D. oscillating

Question 8

The engine produces 2 KJ of energy. 1200 J of this energy is directly transferred into the motion of a vehicle. The rest of the energy is lost as friction.

The efficiency of the system is

- A. 800%
- B. 600%
- C. 80%
- D. 60%

Question 9

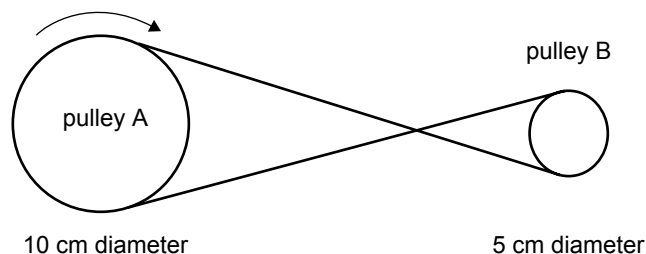

Pulley A, in the diagram above, is 10 cm in diameter and rotates at 40 rpm in a clockwise direction. Pulley B is 5 cm in diameter.

Which of the following is the best estimate of the rpm **and** direction of pulley B?

- A. 20 rpm clockwise
- B. 20 rpm anticlockwise
- C. 80 rpm clockwise
- D. 80 rpm anticlockwise

Question 10

When designing an electronic circuit, you should first build and test the circuit without the need to solder. Which type of board would you use for this task?

- A. electricity board
- B. breadboard
- C. vero board
- D. printed circuit board

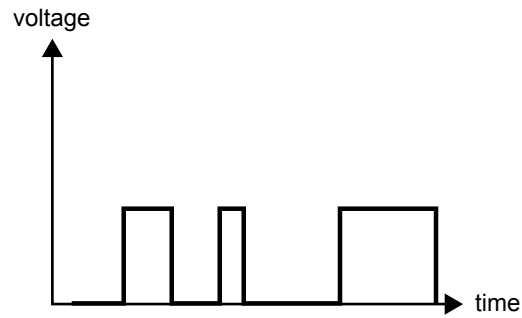
Question 11

The signal shown in this graph is best described as

- A. an alternating current.
- B. analogue.
- C. a direct current.
- D. digital.

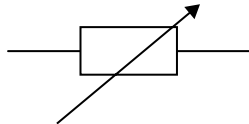
Question 12

This circuit symbol represents which electrical component?

- A. diode
- B. variable resistor
- C. voltage divider
- D. light-dependent resistor

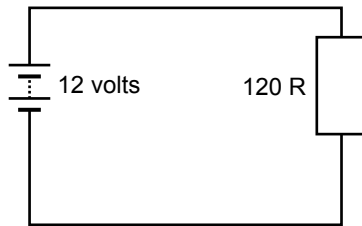
Question 13

The current through the resistor is

- A. 144 mA
- B. 10 A
- C. 1.44 A
- D. 0.1 A

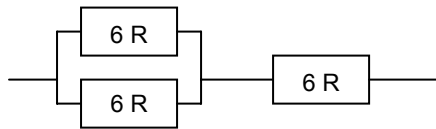
Question 14

The total resistance of the three resistors is

- A. 18 R
- B. 9 R
- C. 2 R
- D. 12 R

Question 15

The colour code for a 120 K, 5% tolerance resistor is

- A. brown red black gold.
- B. brown red red gold.
- C. brown red orange gold.
- D. brown red yellow gold.

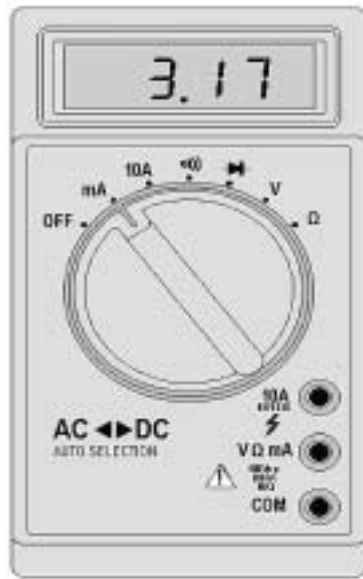
Question 16

The reading of the multimeter is

- A. 317 A
- B. 317 mA
- C. 3.17 mA
- D. 3.17 A

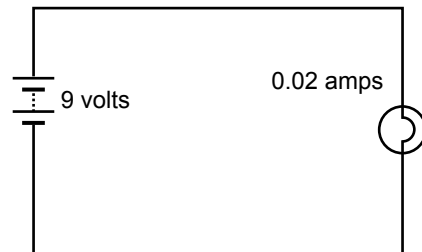
Question 17

The power output of the electric light in the circuit diagram is

- A. 450 mW
- B. 180 mW
- C. 18 W
- D. $\frac{0.02}{9}$ W

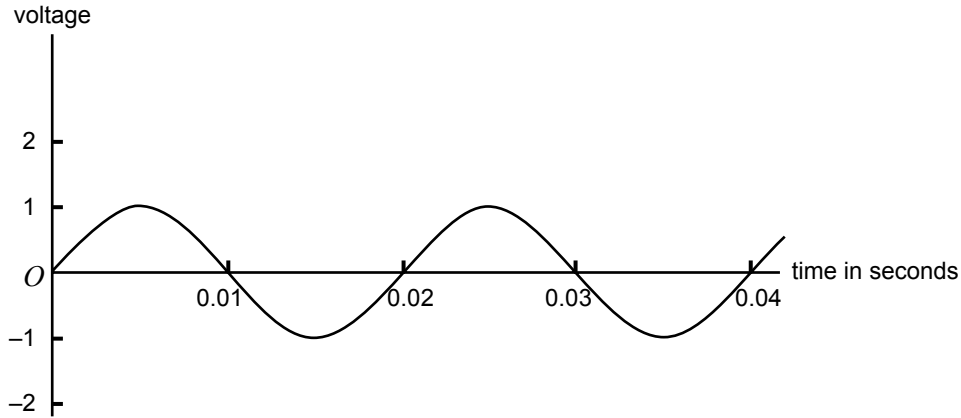
Question 18

The frequency of the signal is

- A. 2 Hz
- B. 4 Hz
- C. 50 Hz
- D. 25 Hz

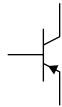
Question 19

The symbol shown represents what type of component?

- A. silicon diode
- B. field effect transistor
- C. PNP transistor
- D. NPN transistor

Question 20

Five possible processes to develop a working integrated system are: diagnostic testing, design, evaluation, simulation and construction.

In what order should these processes be completed?

- A. design, simulation, construction, diagnostic testing, evaluation
- B. simulation, design, diagnostic testing, construction, evaluation
- C. simulation, evaluation, construction, design, diagnostic testing
- D. design, construction, simulation, evaluation, diagnostic testing

SECTION B – Short answer questions

Instructions for Section B
 Answer **all** questions in the spaces provided.
 A formula sheet is provided on page 24.

Question 1

Figure 1a below shows four logic gates. Figure 1b shows four truth tables.

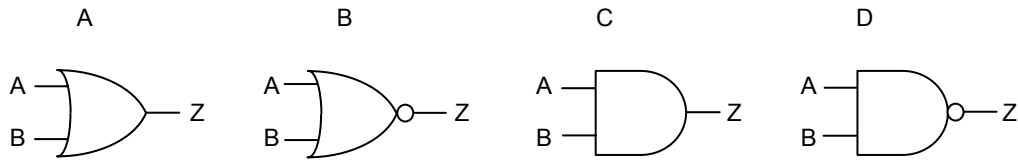

Figure 1a

truth table 1			truth table 2			truth table 3			truth table 4		
A	B	Z	A	B	Z	A	B	Z	A	B	Z
0	0	1	0	0	0	0	0	0	0	0	1
0	1	1	0	1	0	0	1	1	0	1	0
1	0	1	1	0	0	1	0	1	1	0	0
1	1	0	1	1	1	1	1	1	1	1	0

Figure 1b

In the table below, place the number of the appropriate truth table next to the correct logic gate.

logic gate	truth table
A	
B	
C	
D	

3 marks

Question 2

Under each of the four objects below, name the type of force used.



scissors

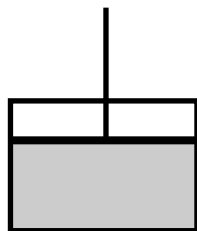

piston

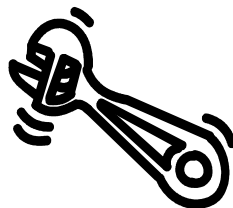

spanner

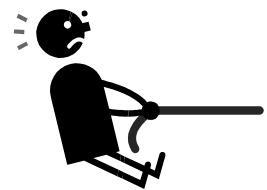

rope

4 marks

Question 3

Under each of the three objects below, name the class of lever for that object.



wheel barrow

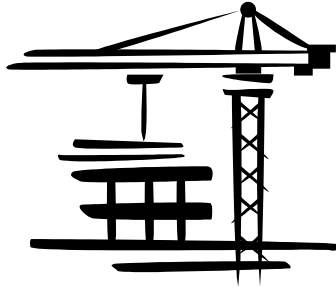

crane

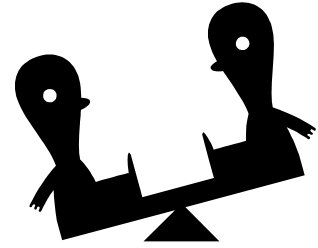

seesaw

3 marks

Question 4

During testing, a prototype of a circuit failed to operate correctly. The designer used a multimeter set on the diode test setting in order to test if a diode in the circuit was faulty.

The following results were obtained.

- When forward biased, the reading was 600 mV.
- When reverse biased, the reading indicated infinity.

What do these results indicate to the designer about the diode being tested?

1 mark

Question 5

Ben, a Systems Engineering student, wants to design a circuit so that two lights can be turned on and off together as safely as possible. Below are Ben's three designs.

Explain what would happen in each of the circuits in the spaces provided.

A

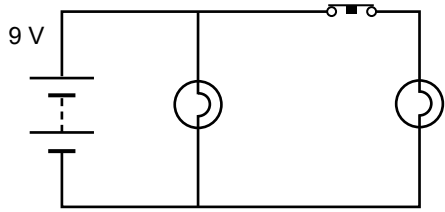

B

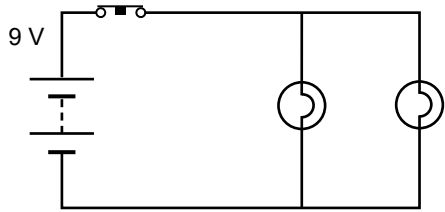

C

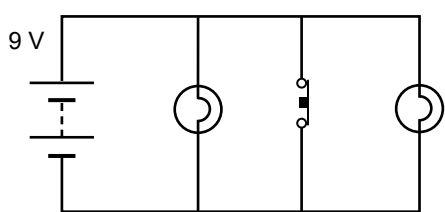

3 marks

Question 6

- a. Describe the principle of operation of the mechanical device in Figure 2.

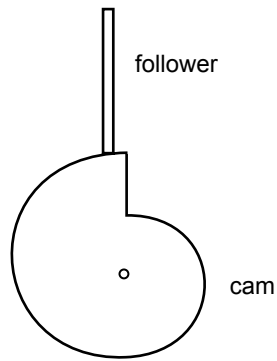

Figure 2

- b. On Figure 2 above, use an arrow to show the correct direction of rotation of the cam.

2 + 1 = 3 marks

Question 7

Risk management and risk assessment are required when planning and manufacturing a system.

- a. Identify two risks associated with using a soldering iron.

i. _____

ii. _____

- b. Explain briefly how you would reduce or eliminate one of these risks.

2 + 1 = 3 marks

The following information relates to Questions 8–22.

Students at Mount Beau High School have designed a tricycle to use in an interschool competition. A side view of the tricycle is shown in Figure 3 below.

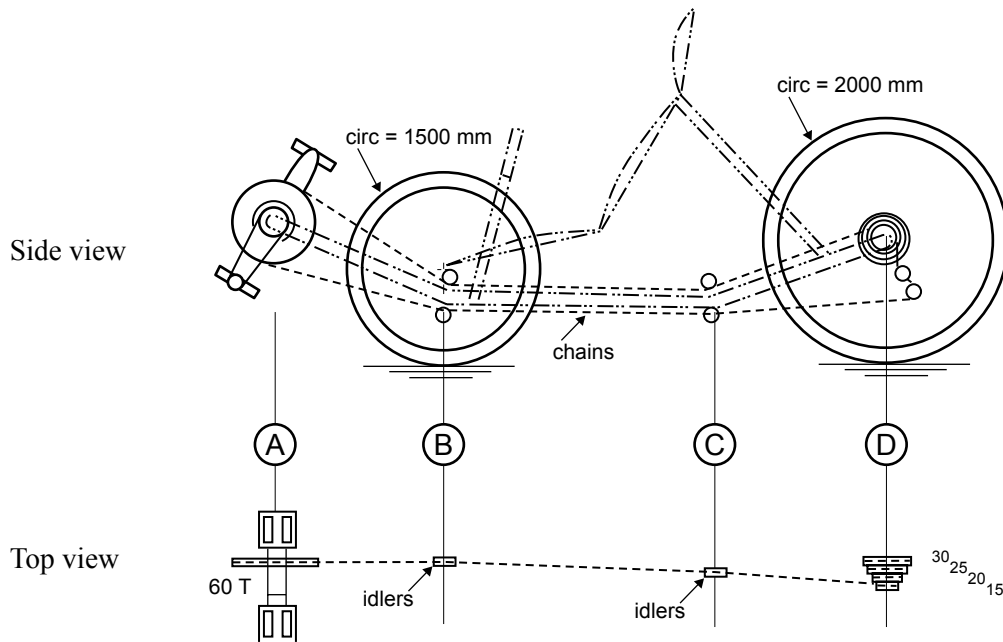
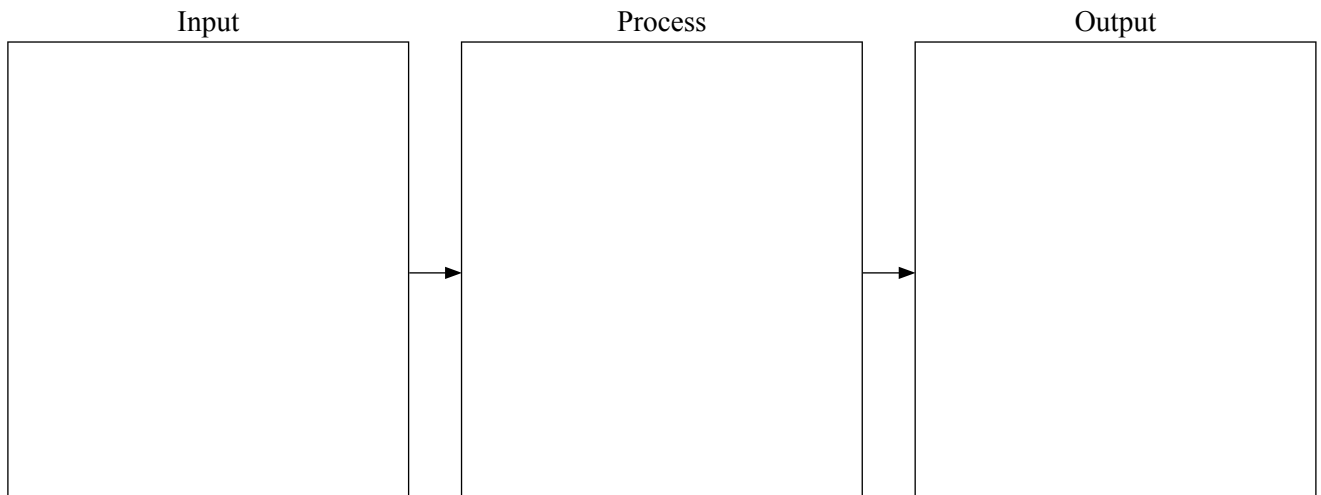

Figure 3

Question 8

Complete the systems block diagram for the tricycle.



3 marks

Question 9

Where are the following motions found in the operation of the tricycle?

rotary _____

linear _____

2 marks

The drive system of the tricycle has the following specifications.

- crank (gear A) – 60 teeth
- wheel sprocket (gear D) – 15 teeth

Question 10

What is the gear ratio? Show working and write your answer in the box below.

2 marks

The idler gears are replaced by intermediate gears. You now need to achieve a gear ratio for gear A to gear D of 12:1. To achieve this gear ratio you will need to determine the size of gears 1, 2, 3 and 4.

Question 11

Write the number of teeth on each gear in the box provided in Figure 4 below.

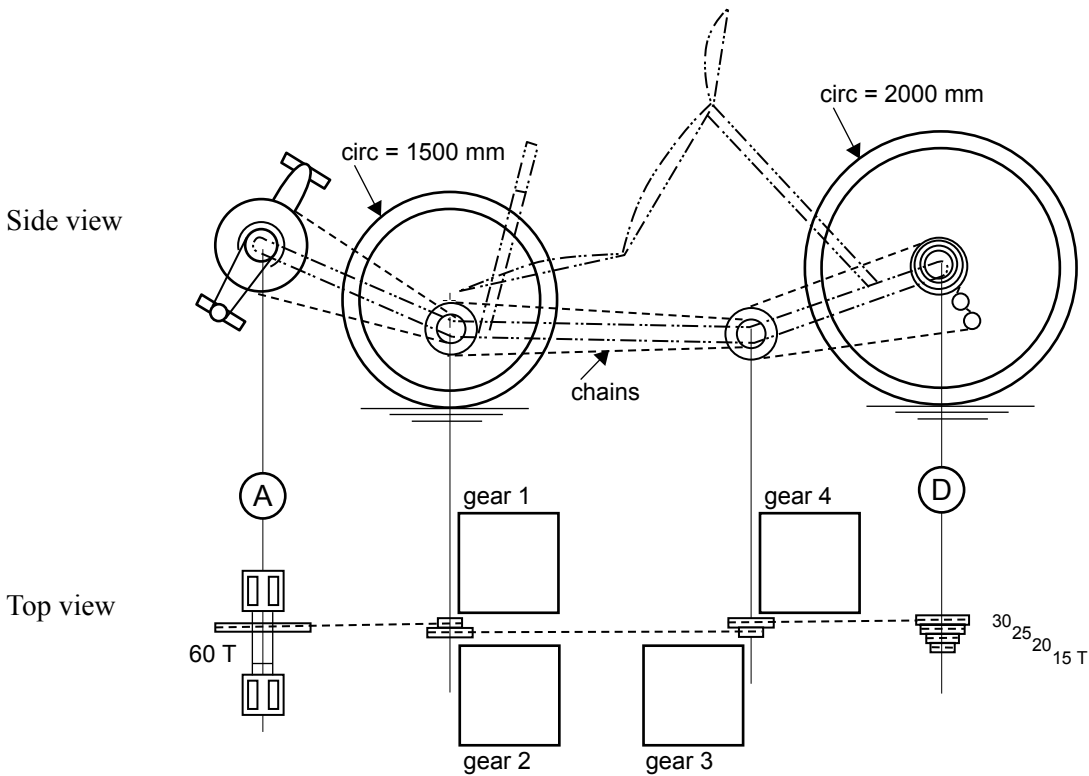

Figure 4

2 marks

Question 12

a. Name one place on the tricycle (excluding brakes) where friction takes place.

b. Explain how to reduce this friction.

1 + 1 = 2 marks

The designer of the tricycle claims that it can reach a speed of 72 km/h, which can be converted to 20 m/s.

Question 13

a. Describe a test, using a tape measure and watch, that could prove the designer's claim.

b. To confirm the designer's claim, and using your test above, what is the expected reading on your stop watch?

2 + 1 = 3 marks

One of the problems with a chain drive is that the chain can stretch and increase in length.

Question 14

To overcome this problem, draw a chain tensioning system for the chain which runs from the pedals to the first gear. Draw the systems on Figure 5 below.

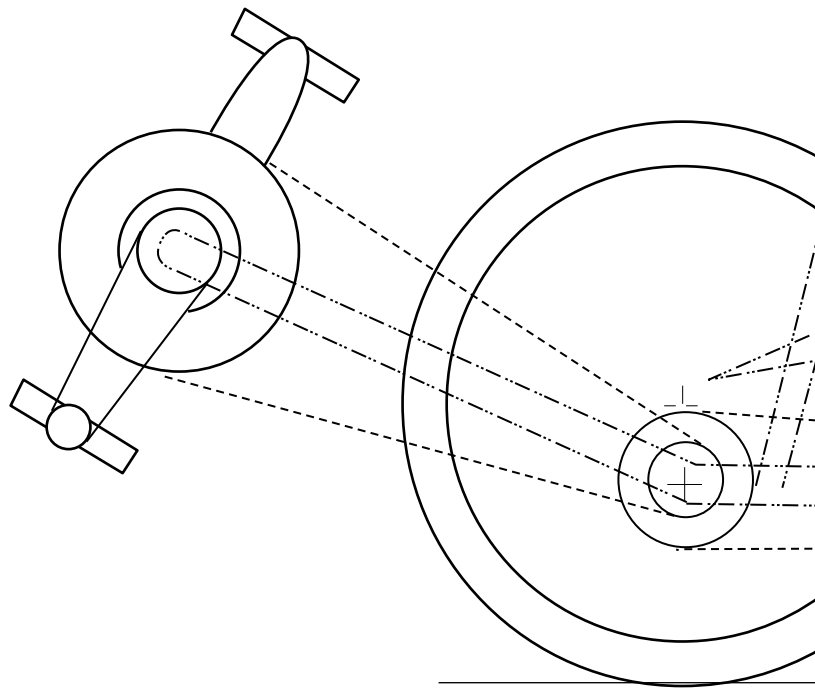

Figure 5

3 marks

The designer of the tricycle decides to put a motor in the tricycle so that it will go faster. This can be seen in Figure 6 below.

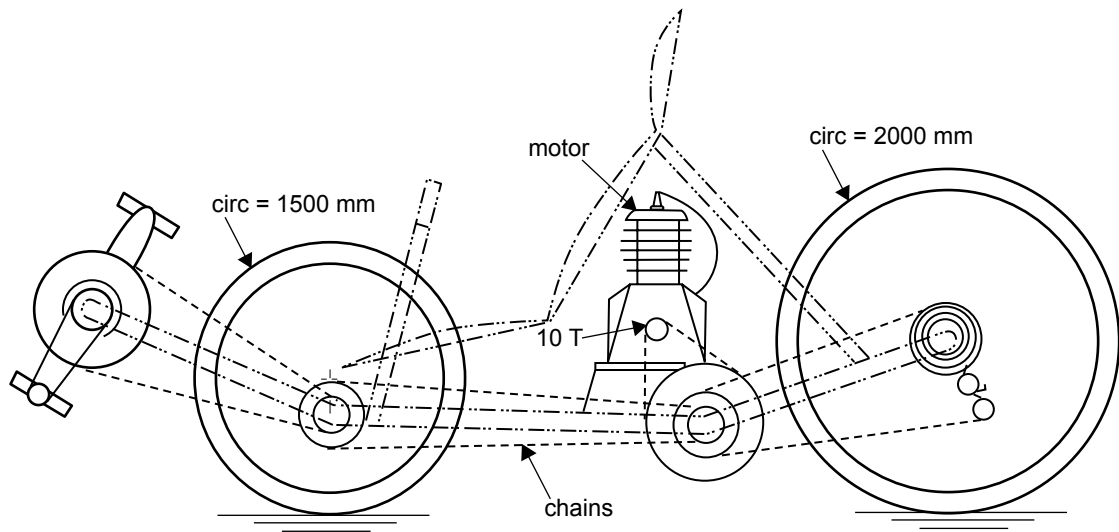

Figure 6

Question 15

Name three environmental issues to consider when putting a motor in the tricycle.

- i. _____
- ii. _____
- iii. _____

3 marks

Michael, who will ride the tricycle, needs to make sure he is visible while he is riding.

To achieve this, Michael has obtained an oscillator circuit as shown in the schematic diagram, Figure 7, below. Michael will attach the system to the tricycle.

Two high-intensity light emitting diodes (LEDs) are to be installed with a white LED at the front and a red LED at the rear.

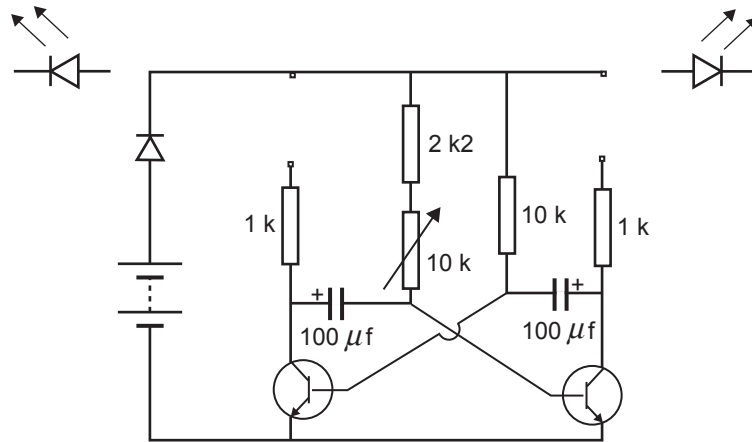

Figure 7

Question 16

On Figure 7, show the correct connections to join the light emitting diodes (LEDs) to the circuit diagram.

2 marks

Question 17

Complete the system block diagram for the oscillator circuit diagram.

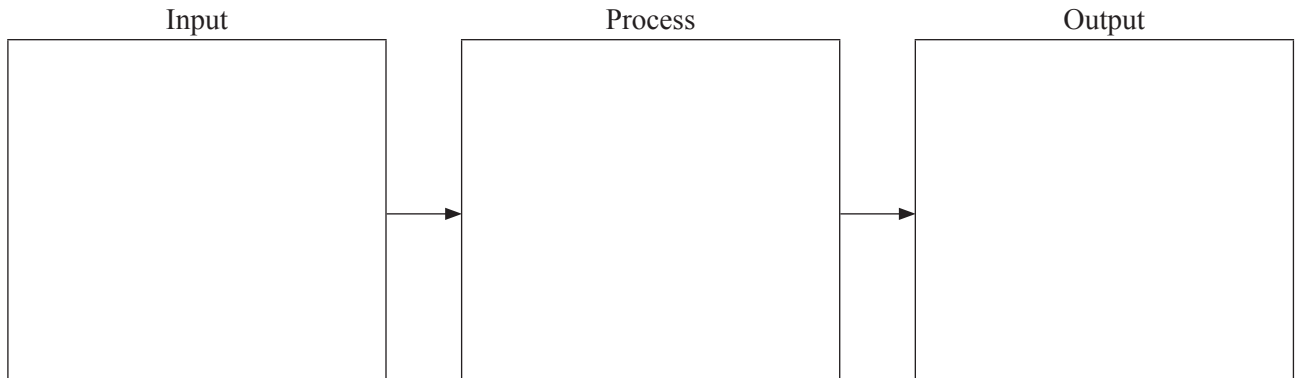

3 marks

Question 18

Name the symbols below, which are used in the schematic oscillator circuit diagram (Figure 7).

i.

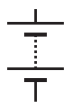

ii.

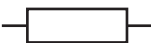

iii.



1 + 1 + 1 = 3 marks

Figure 8a shows a segment of the oscillator circuit diagram. Figure 8b shows this segment with a change made.

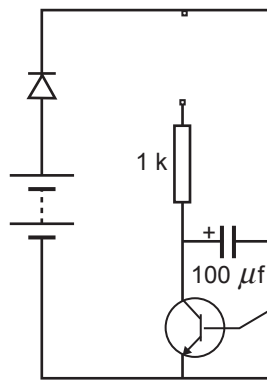

Figure 8a

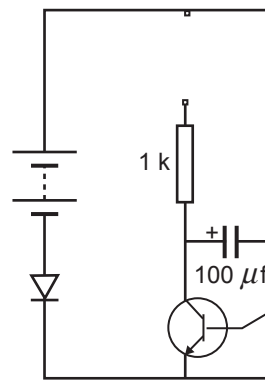

Figure 8b

Question 19

What is the effect on the operation of the oscillator circuit if the change in Figure 8b is made?

2 marks

The oscillator circuit diagram is shown in Figure 9a. An incomplete circuit board is shown in Figure 9b.

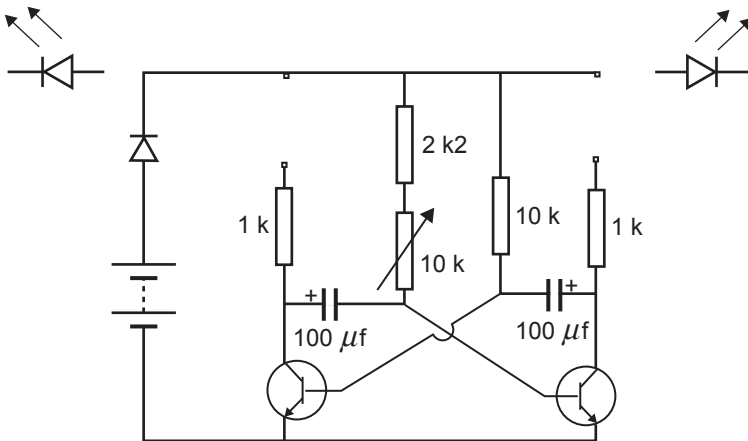

Figure 9a

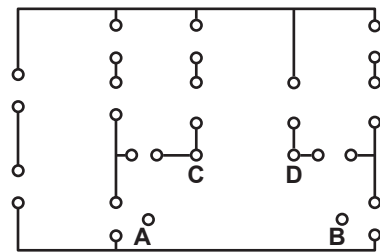

Figure 9b

Question 20

Correctly join points A, B, C and D on the circuit board (Figure 9b) to complete the circuit.

2 marks

The variable resistor (Figure 10) of the oscillator circuit, which allows a variation of the flash rate, is set to 30% of its stated value.

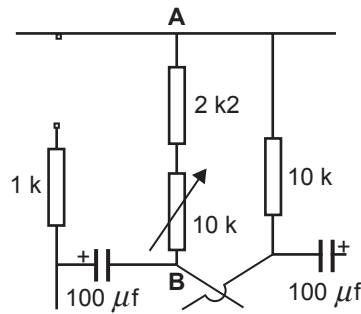

Figure 10

Question 21

Calculate the total resistance between points A and B. Show all working and write your answer in the box below.

2 marks

One of the BC 548 semiconductors in the oscillator circuit requires replacement due to damage.

The supplier can only supply a BC 558.

Below is data for both the BC 548 and the BC 558.

BC 548	
Case style	TO – 92
General description	Small signal NPN semiconductor for switching and amplifier applications
Collector – base voltage	30 volts
Collector – emitter voltage	30 volts
Collector current	100 mA
Power dissipation	625 mW

BC 558	
Case style	TO – 92
General description	Small signal PNP semiconductor for switching and amplifier applications
Collector – base voltage	30 volts
Collector – emitter voltage	30 volts
Collector current	100 mA
Power dissipation	500 mW

Question 22

Explain whether the BC 558 is a suitable replacement component for the BC 548 in the oscillator circuit.

2 marks

Question 23

Below is a list of technical terms. Match four words from the list with the definitions given.

- light-dependent resistor
- electrotechnology
- digital signals
- analogue signal
- rectifier
- integrated circuit
- transformer
- voltage regulator

Definition 1 – A single electronic component that contains within it circuitry to perform a set of functions.

Definition 2 – A device that converts Alternating Current (AC) to Direct Current (DC) unregulated.

Definition 3 – A device which provides a stable DC voltage power source within the specified current range of the device.

Definition 4 – Data that is delivered in Binary form.

4 marks

Coal power stations are one of the biggest producers of greenhouse gases. An alternative source of energy is a nuclear power station as shown in Figure 11.

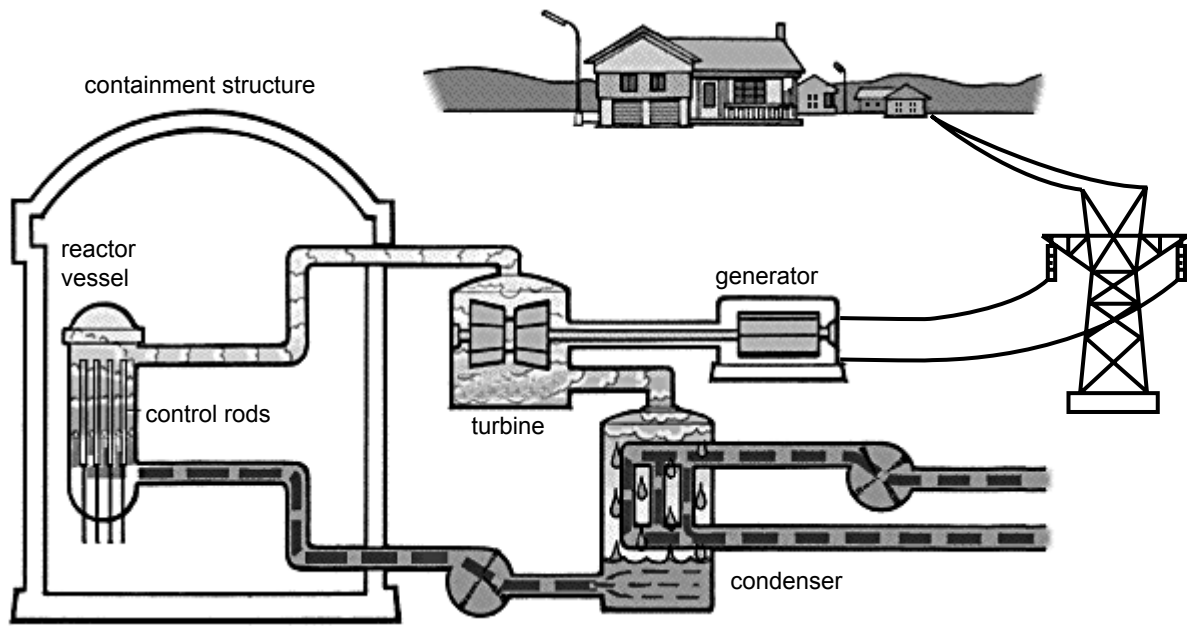

Nuclear power station

Figure 11

Question 24

Using the block diagram below, describe how a nuclear reactor works. Include the input, output and process. Describe the process in terms of energy conversions.

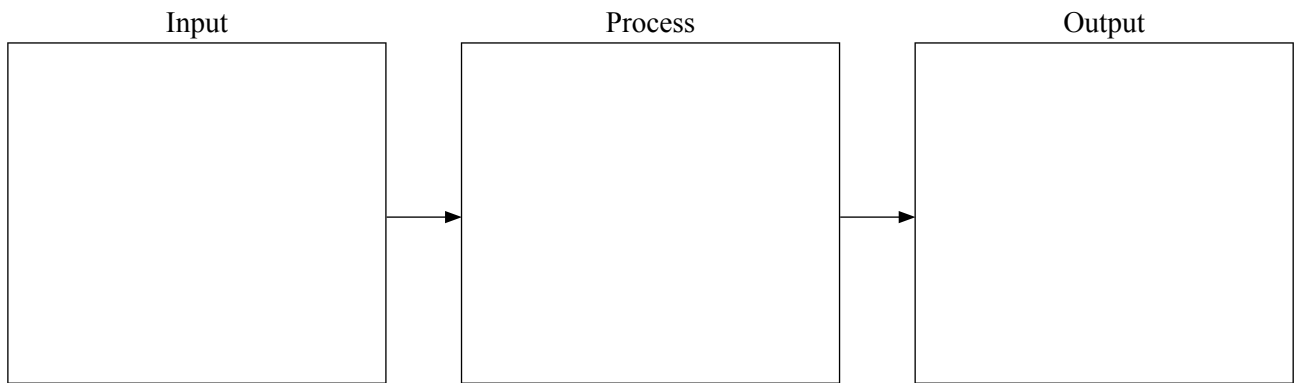

3 marks

Question 25

Using Figure 11 above, describe three energy conversions in the power station.

- i. _____
- ii. _____
- iii. _____

3 marks

Question 26

- a. Give **one** environmental **advantage** of using nuclear technology. (Use scientific terms.)

- b. Give **one** environmental **disadvantage** of using nuclear technology. (Use scientific terms.)

2 + 2 = 4 marks

Formula sheet

Work done = force \times distance moved

Gear ratio = $\frac{\text{number of teeth driver gear}}{\text{number of teeth driven gear}}$

Gear ratio final = gear ratio 1 \times gear ratio 2

Efficiency = $\frac{\text{output energy}}{\text{input energy}} \times 100\%$

Voltage = current \times resistance

Resistance in parallel = $\frac{R_1 \times R_2}{R_1 + R_2}$

Resistance in series = $R_1 + R_2$

Colour codes

Colour	Value
black	0
brown	1
red	2
orange	3
yellow	4
green	5
blue	6
violet	7
grey	8
white	9
gold	5%
silver	10%

Moment = force \times distance

Velocity = $\frac{\text{displacement}}{\text{time}}$

$P = V \times I$

$Q = C \times V$

$V = I \times R$

Frequency = $\frac{1}{\text{period}}$

$\frac{\text{force}_b}{\text{force}_a} = \frac{\text{cross sectional area}_a}{\text{cross sectional area}_b}$

END OF QUESTION AND ANSWER BOOK