



Victorian Certificate of Education 2009

SUPERVISOR TO ATTACH PROCESSING LABEL HERE

STUDENT NUMBER

Figures

Words

Letter

--

SYSTEMS ENGINEERING

Written examination

Friday 13 November 2009

Reading time: 9.00 am to 9.15 am (15 minutes)

Writing time: 9.15 am to 10.45 am (1 hour 30 minutes)

QUESTION AND ANSWER BOOK

Structure of book

<i>Section</i>	<i>Number of questions</i>	<i>Number of questions to be answered</i>	<i>Number of marks</i>
A	20	20	20
B	18	18	50
			Total 70

- Students are permitted to bring into the examination room: pens, pencils, highlighters, erasers, sharpeners, rulers and one scientific calculator.
- Students are NOT permitted to bring into the examination room: blank sheets of paper and/or white out liquid/tape.

Materials supplied

- Question and answer book of 25 pages including formulas on page 25.
- Answer sheet for multiple-choice questions.

Instructions

- Write your **student number** in the space provided above on this page.
- Check that your **name** and **student number** as printed on your answer sheet for multiple-choice questions are correct, **and** sign your name in the space provided to verify this.
- All calculations must show appropriate formulas and working.
- All written responses must be in English.

At the end of the examination

- Place the answer sheet for multiple-choice questions inside the front cover of this book.

Students are NOT permitted to bring mobile phones and/or any other unauthorised electronic devices into the examination room.

SECTION A – Multiple-choice questions**Instructions for Section A**

Answer **all** questions in pencil on the answer sheet provided for multiple-choice questions.

Choose the response that is **correct** for the question.

A correct answer scores 1, an incorrect answer scores 0.

Marks will **not** be deducted for incorrect answers.

No marks will be given if more than one answer is completed for any question.

A formula sheet is provided on page 25.

Questions 1 and 2 refer to the diagram below.

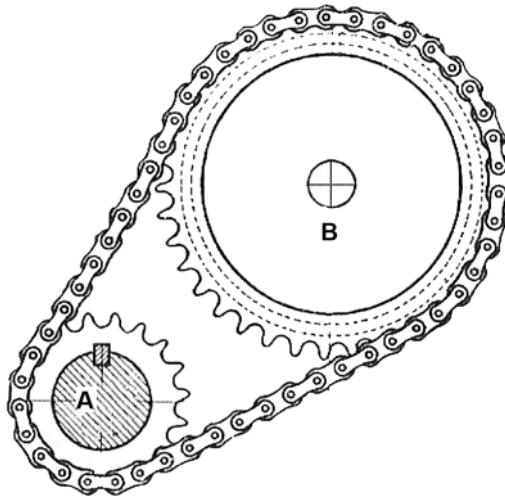

Sprocket A drives sprocket B using a chain as shown in the diagram.

Question 1

Given that sprocket A has 19 teeth and rotates at 1500 rpm, what is the rpm of sprocket B which has 38 teeth?

- A. 750 rpm
- B. 1000 rpm
- C. 1750 rpm
- D. 3000 rpm

Question 2

When transferring power from sprocket A to sprocket B, the chain that connects sprocket A to sprocket B is subject to which of the following forces?

- A. compression
- B. tension
- C. torsion
- D. sheer

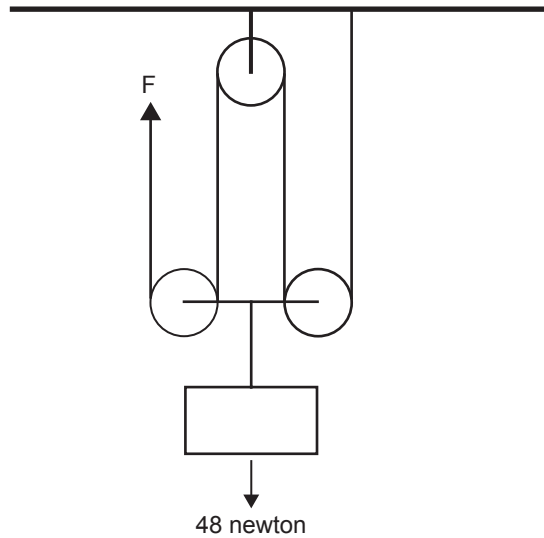
Question 3

In the diagram above, the force, F , needed to hold the weight still is

- A. 12 newton.
- B. 16 newton.
- C. 24 newton.
- D. 48 newton.

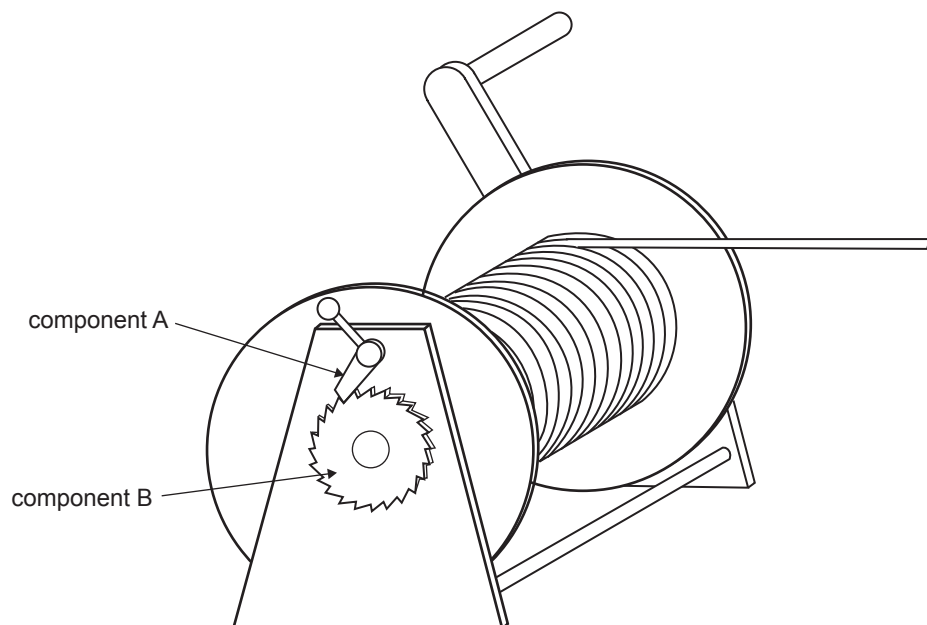
Question 4

Component A on the diagram above interlocks with component B to stop the winch from being released.

Component A is called a

- A. pawl.
- B. clutch.
- C. ratchet.
- D. free wheel.

Question 5

A boat winch has a driver gear of 20 teeth and a driven gear of 160 teeth.

What is the gear ratio?

- A. 0.125:1
- B. 1:8
- C. 8:1
- D. 16:1

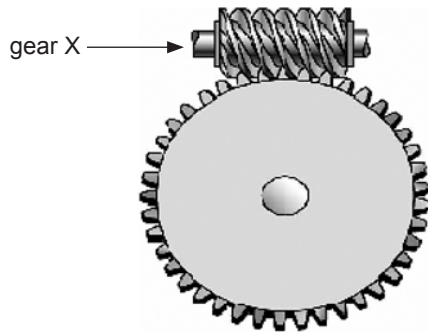
Question 6

Gear X shown in the diagram above is a

- A. worm gear.
- B. crown gear.
- C. bevel gear.
- D. rack gear.

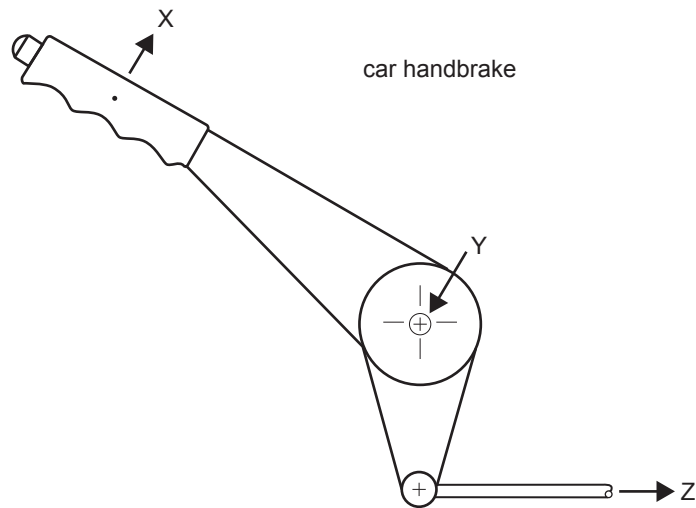
Question 7

On the diagram of the car handbrake lever above, what is the correct position of the effort, load and fulcrum?

- | | effort | load | fulcrum |
|-----------|--------|------|---------|
| A. | X | Y | Z |
| B. | Z | Y | X |
| C. | Y | X | Z |
| D. | X | Z | Y |

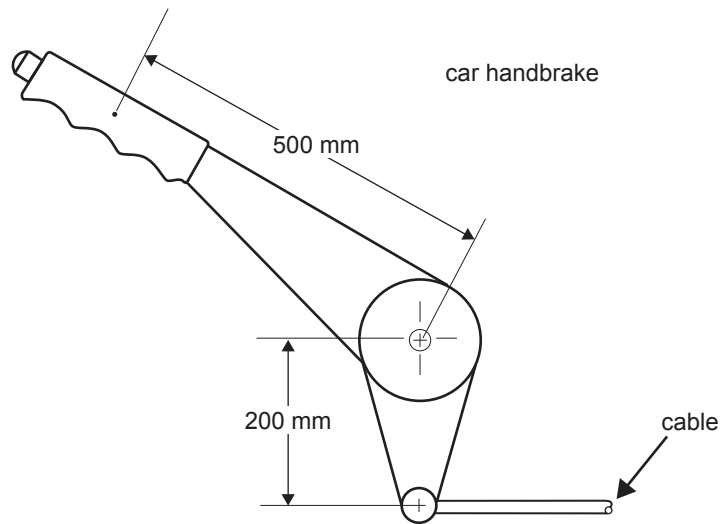
Question 8

On the diagram above, the force applied to the handbrake lever by the operator's hand is 40 N.

What is the force applied to the cable?

- A.** 100 N
- B.** 200 N
- C.** 300 N
- D.** 700 N

Question 9

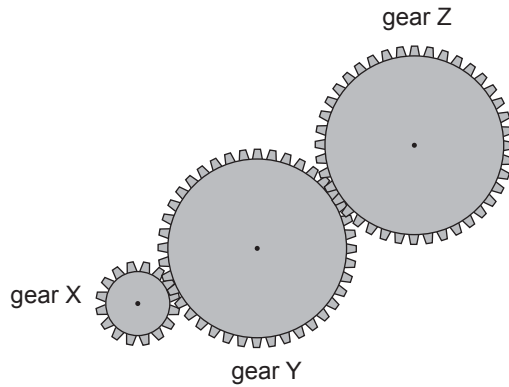

In the diagram above, if gear X moves clockwise then gear Z will rotate

- A. clockwise and faster than gear X.
- B. clockwise and slower than gear X.
- C. anticlockwise and faster than gear X.
- D. anticlockwise and slower than gear X.

Question 10

Which of the following statements about hydrogen fuel cells is true?

- A. Hydrogen fuel cells can only be used in cars.
- B. A hydrogen fuel cell is a battery that uses hydrogen.
- C. Hydrogen fuel cells convert hydrogen and oxygen to water.
- D. Hydrogen fuel cells produce heat, which is then transformed into electricity.

Question 11

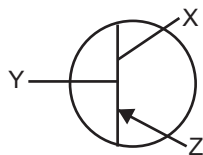

The correct labelling order for the three terminals of the junction transistor above is

- A. X = base Y = collector Z = emitter
- B. X = collector Y = base Z = emitter
- C. X = emitter Y = collector Z = base
- D. X = collector Y = emitter Z = base

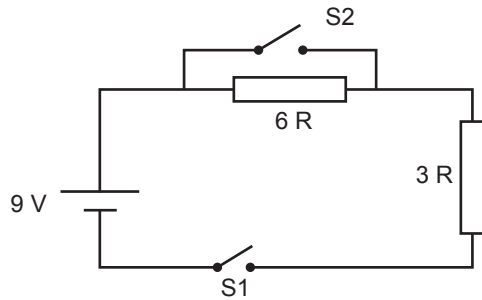
Question 12

The electric current flowing from the 9-volt battery in the circuit above depends on the state of switches S1 and S2.

Which of the combinations below will give the greatest electric current flowing from the battery?

- A. S1 open S2 open
- B. S1 open S2 closed
- C. S1 closed S2 closed
- D. S1 closed S2 open

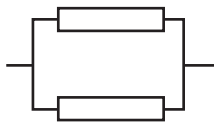
Question 13

arrangement 1



arrangement 2

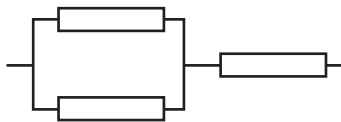

arrangement 3

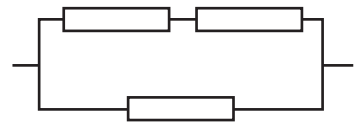

arrangement 4

Each single resistor in the arrangements shown above has a value of 3 ohms.

Which arrangement will have a combined resistance of 2 ohms?

- A. arrangement 1
- B. arrangement 2
- C. arrangement 3
- D. arrangement 4

Question 14

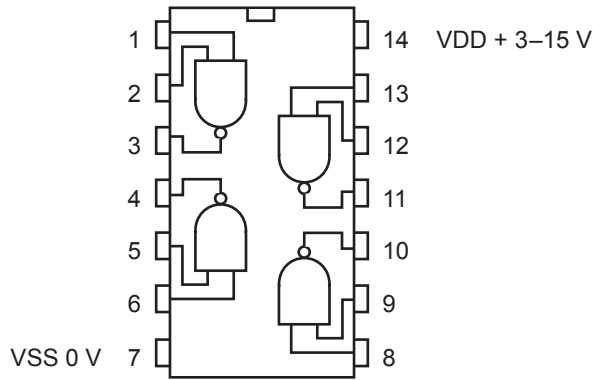

4011 integrated circuit

The 4011 integrated circuit shown above has four logic gates. To test the logic gate connected to pins 1, 2 and 3, voltage values are measured and recorded as high or low.

Which table below represents a correct operation of that logic gate?

A.

pin	voltage
1	high
2	low
3	low

B.

pin	voltage
1	high
2	high
3	low

C.

pin	voltage
1	low
2	low
3	low

D.

pin	voltage
1	low
2	high
3	low

Question 15

In the past, solder wire used in the construction of electronic circuits contained a metal linked to a health hazard.

This hazardous metal was

- A. tin.
- B. iron.
- C. lead.
- D. copper.

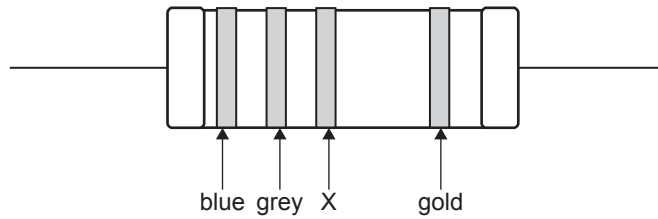
Question 16

A resistor with a resistance value between 560 ohms and 1200 ohms is needed for a project. The four-band resistor with the colours shown will meet this requirement if colour X is

- A. yellow.
- B. brown.
- C. black.
- D. red.

Question 17

Sound energy is converted into electrical energy in

- A. a piezo buzzer.
- B. a loudspeaker.
- C. a microphone.
- D. an amplifier.

Question 18

A semiconductor is used in the construction of

- A. a transformer.
- B. a relay.
- C. a light-emitting diode.
- D. an electrolytic capacitor.

Question 19

A flow chart for a microcontroller program is given below.

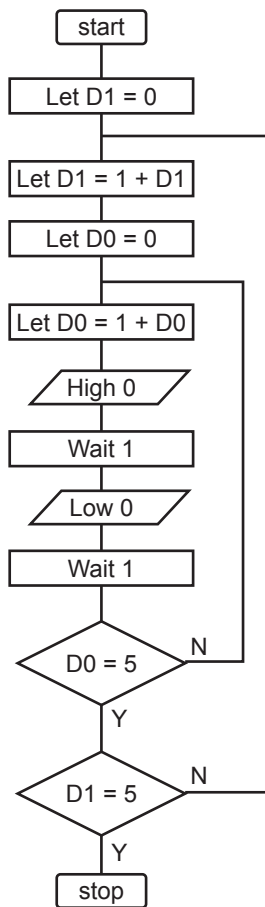

High 0 turns a light-emitting diode (LED) on. Low 0 turns it off. 'Wait 1' is a one-second delay. How many times will the LED turn on and off in this program?

- A. once
- B. 10 times
- C. 20 times
- D. 25 times

Question 20

At a work station, the correct work sequence to reduce the risk of injury to a person is

- A. risk assessment, hazard identification, risk control.
- B. hazard identification, risk assessment, risk control.
- C. risk assessment, risk control, hazard identification.
- D. risk control, hazard identification, risk assessment.

CONTINUES OVER PAGE

TURN OVER

SECTION B – Short answer questions

Instructions for Section B

Answer **all** questions in the spaces provided.
 A formula sheet is provided on page 25.

An airport has an automated departure baggage transportation system. The transportation system takes baggage from the check-in counter to a haulage cart which in turn takes the baggage to the aeroplane. The baggage transportation system uses three conveyor belts as shown in Figure 1 below.

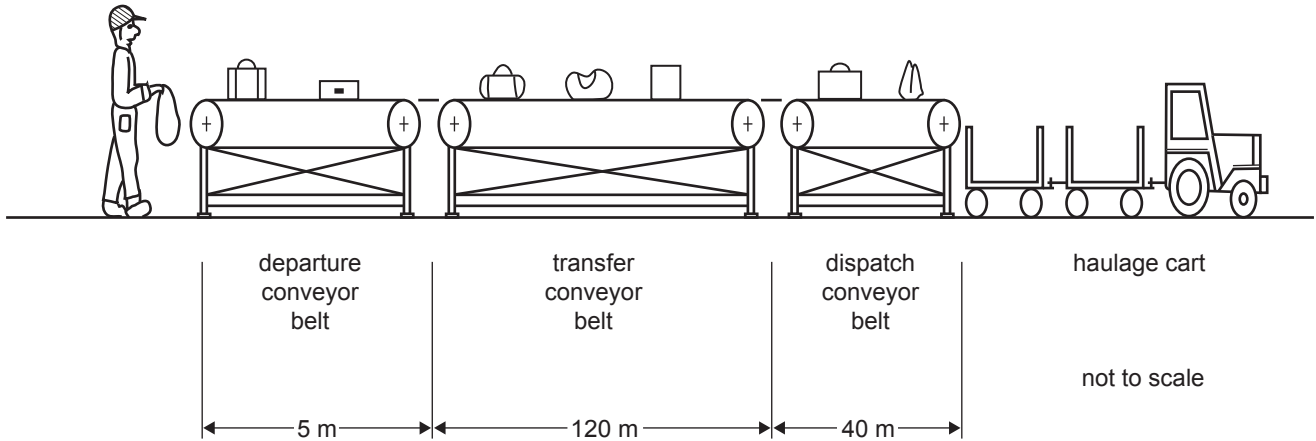

Figure 1

Question 1

Name the type of motion associated with the movement of the baggage on the departure conveyor belt.

1 mark

The departure conveyor belt is 5 m long and a bag, moving at constant speed, takes 10 seconds to travel its length.

Question 2

Calculate the speed of the bag in m/s. Show working.

2 marks

Baggage reaching the end of the departure conveyor belt is automatically loaded onto the transfer conveyor belt. The transfer conveyor belt is 120 m long and moves at 2 m/s.

Question 3

- a. If 20 bags per minute are placed on the departure conveyor belt, how many bags per minute reach the far end of the transfer conveyor belt?

1 mark

- b. Calculate the distance in metres between one bag and the bag following it on the transfer conveyor belt. Assume that the bags are equally spaced on the conveyor belt.

1 mark

Question 4

The dispatch conveyor belt is expected to move at a speed of 1 m/s. The operator needs to check that the actual speed of the dispatch conveyor belt is close to the expected speed.

- a. Name one test instrument that could be used to test the speed of the dispatch conveyor belt.

1 mark

- b. Describe a test procedure using the test instrument named in **part a.** that an operator could follow to measure the actual speed of the dispatch conveyor. (List the steps in the procedure.)

2 marks

The pulley and belt drive system of the departure conveyor belt is powered by a 240-volt electric motor rotating at 1200 revolutions per minute, as shown in Figure 2 below.

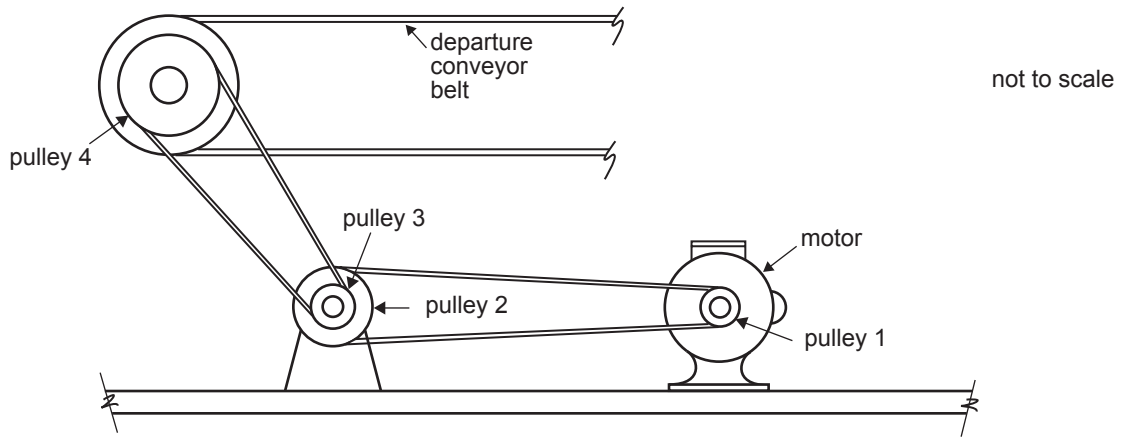

Figure 2 pulley and belt drive system

Question 5

- a. Identify one potential safety hazard of the pulley and belt drive system for the operator of the departure conveyor belt.

1 mark

- b. Describe a solution to this hazard.

1 mark

The drive system of the departure conveyor belt consists of 4 pulleys as shown in Figure 2.

Question 6

You wish to design a pulley system with a reduction ratio of 24:1. For this design you only have the choice of pulleys with the following diameters: 50 mm, 100 mm, 150 mm, 200 mm, 250 mm, 300 mm, 350 mm, 400 mm. Write your pulley selection in the table below.

	diameter
pulley 1	
pulley 2	
pulley 3	
pulley 4	

2 marks

A front view of pulley 2 and pulley 3 is shown in Figure 3a. Pulley 2 and pulley 3 are attached to a shaft and housing as shown in Figure 3b below.

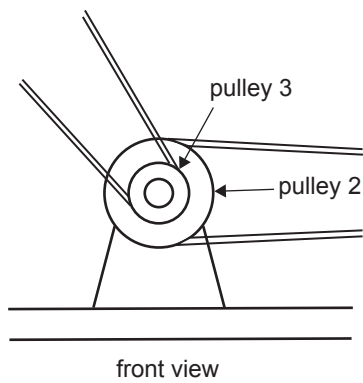

Figure 3a

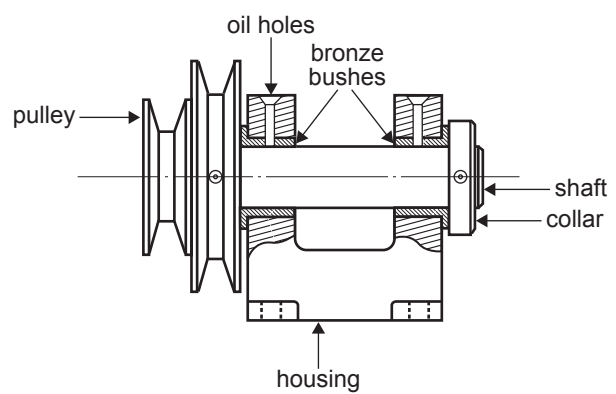

Figure 3b

Question 7

The bronze bushes must be lubricated daily and you decide to replace them with a device that does not need maintenance. Draw and label a maintenance-free alternative in Figure 4 below.

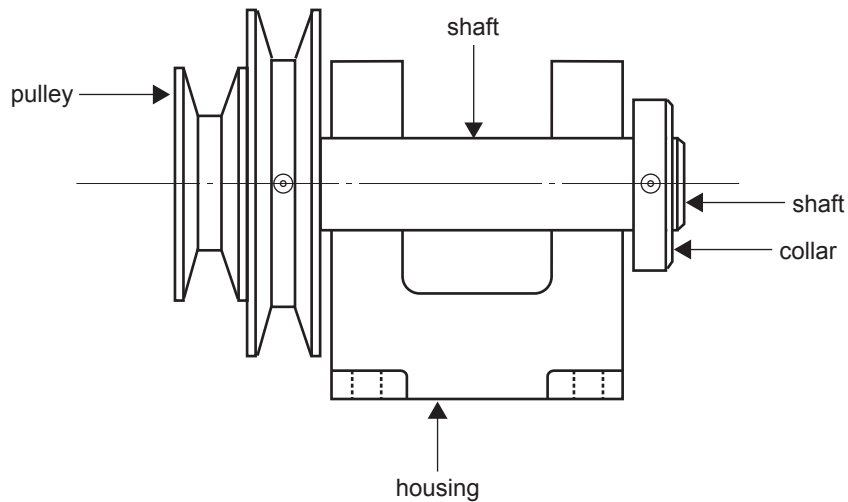

Figure 4 pulley assembly

2 marks

Question 8

The pulley drive system of the conveyor belt system (Figure 2) is reprinted below.

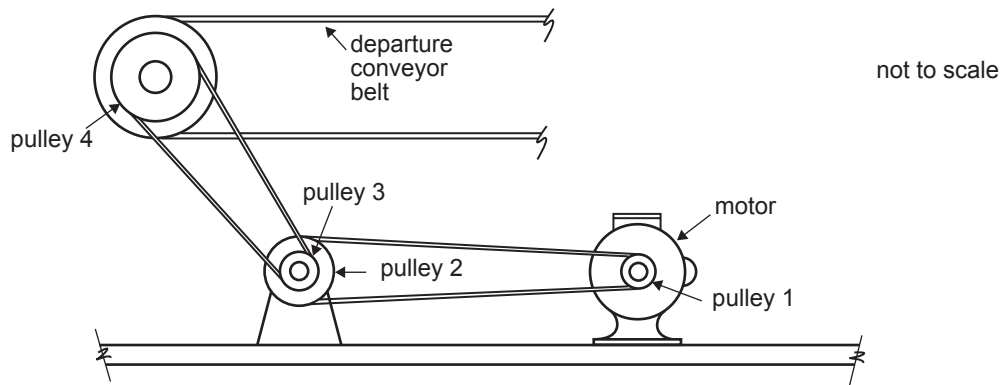

Figure 2 pulley and belt drive system (repeated)

You now need to design a simple mechanical engagement/disengagement system between the motor and the departure conveyor belt.

a. Clearly draw and label the mechanism on Figure 5 below.

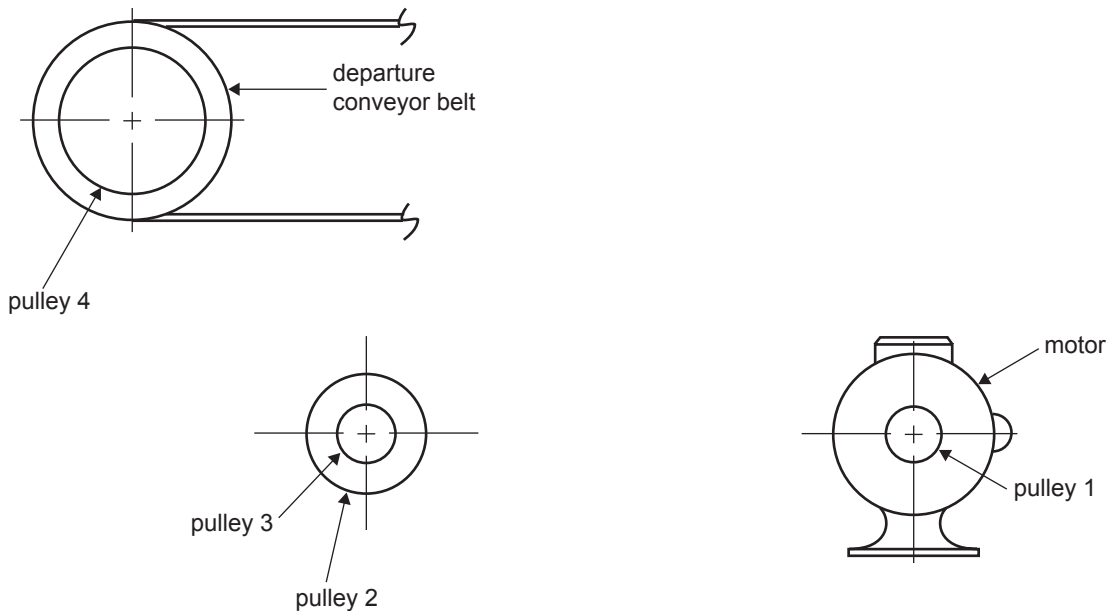

Figure 5

2 marks

b. Explain the operation of your mechanical engagement/disengagement system.

1 mark

The check-in operator needs to be able to stop the departure conveyor belt motion and restart it when required. Two designs, circuit A and circuit B below, are proposed for the electric control of the motor.

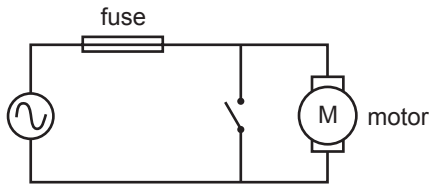

circuit A

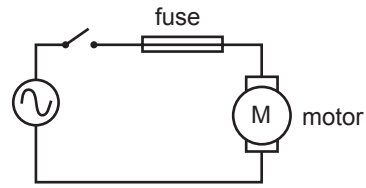

circuit B

Question 9

Explain what would happen if you closed the switch in each of the above circuits.

circuit A _____

circuit B _____

2 marks

The electric motor driving the departure conveyor belt is run from 240 VAC and has 10 amperes going through it.

Question 10

a. What does VAC stand for?

1 mark

b. Calculate the power input to the motor. Show working.

2 marks

c. Calculate the impedance (resistance) of the motor. Show working.

2 marks

Question 11

Complete the systems block diagram for the electric motor driving the conveyor belt in **terms of accepted forms of energy**. Give the input, desired output and undesired output only.

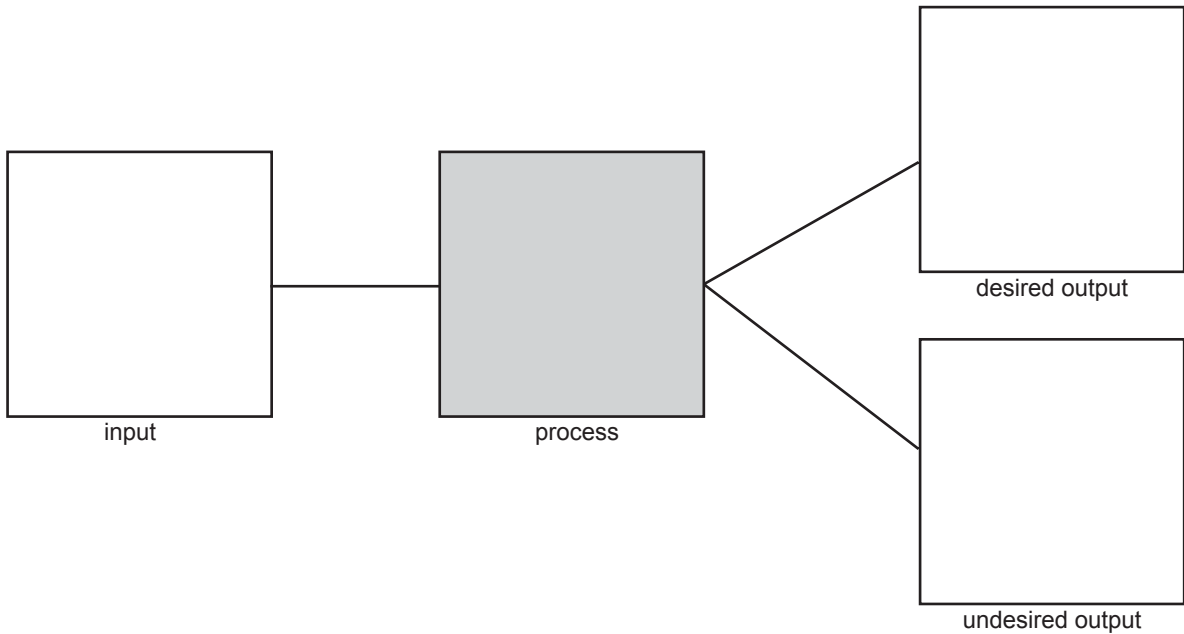

3 marks

Some of the baggage on the dispatch conveyor belt needs to be directed to a different destination. A barcode placed on the side of a bag is read on the conveyor and activates the redirecting mechanism in Figure 6a below. A compressed air system is used to provide the force needed to move the deflector arm. This is shown in Figure 6b below.

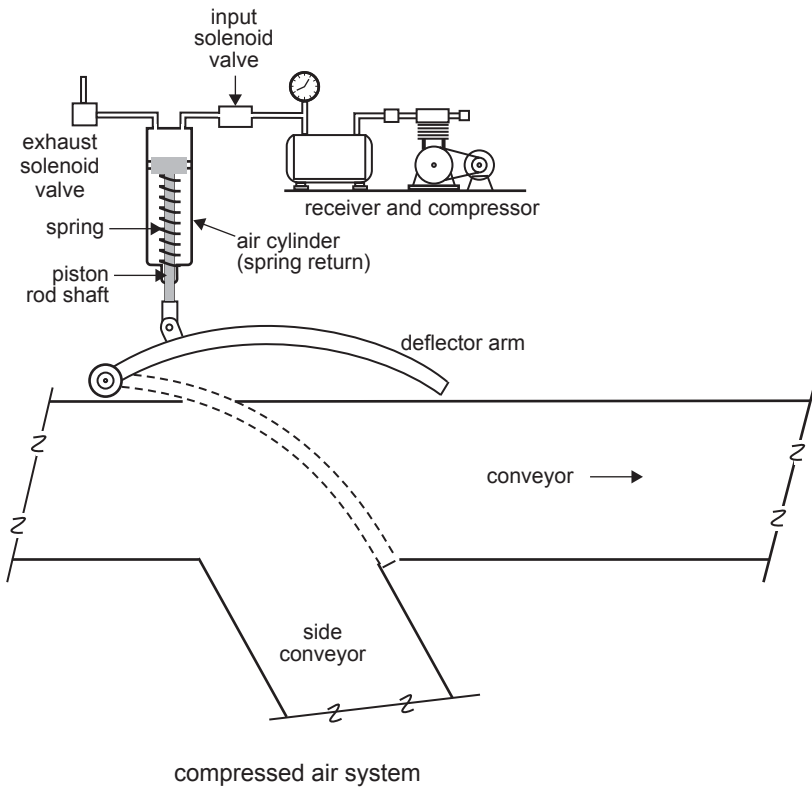

Figure 6a

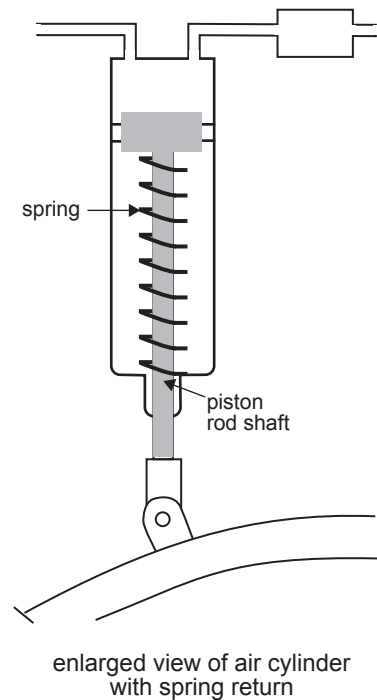

Figure 6b

Question 12

The air cylinder has a diameter of 200 mm and the piston rod has a diameter of 30 mm. If the receiver air pressure is 10 000 pascals, calculate the force applied to the piston by the compressed air. Show working.

3 marks

It was found that the air cylinder did not have quite enough power to operate the deflector properly.

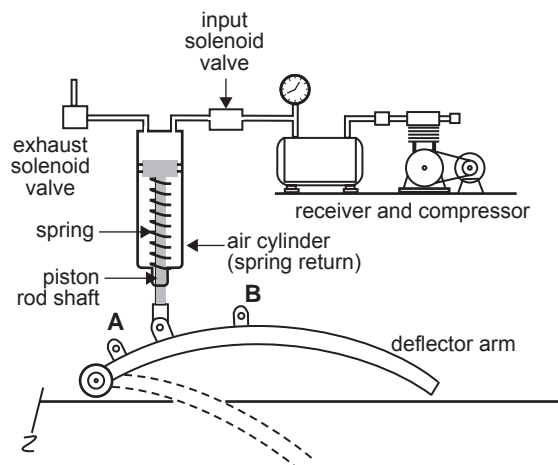
**Question 13**

- a. To solve this problem, you need to connect the piston rod shaft to either point A or point B. Where will you connect the piston rod shaft? Explain your choice.

1 mark

- b. How does this modification adversely affect the operation of the system?

1 mark

At the check-in counter, a barcode sticker is placed on the side of each bag. A barcode reader is placed 4 m before each deflector on the dispatch conveyor belt. The barcode is then read as a digital signal.

Question 14

On the axes below, sketch a typical digital signal.

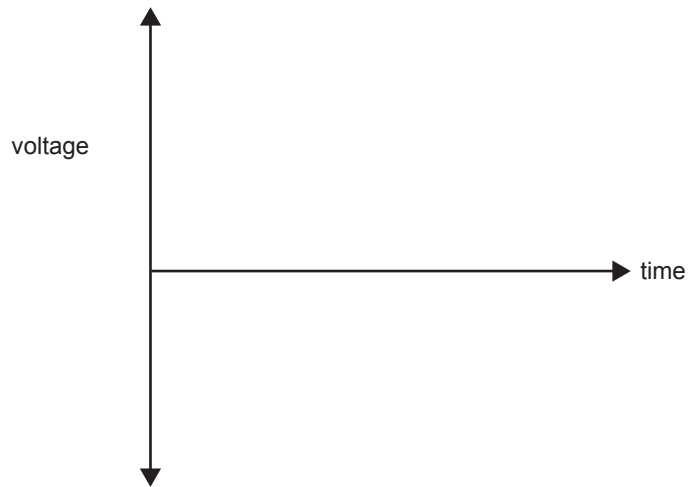

1 mark

The dispatch conveyor belt moves at 1 m/s. A delay of 3 seconds is needed to allow the bag time to get from the barcode reader to the deflector. When the voltage at point C drops to a set value, the electronic circuitry activates the deflector. The deflector moves across for 2 seconds while the bag is deflected then returns to its original position. One way of gaining a delay is to use a resistor in series with a capacitor. A possible delay circuit is given in Figure 7 below.

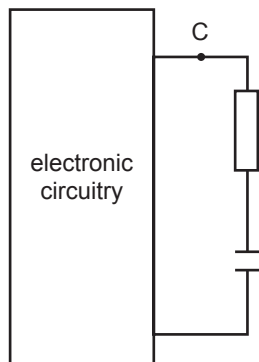

Figure 7

The voltage at point C drops as shown in Figure 8 below.

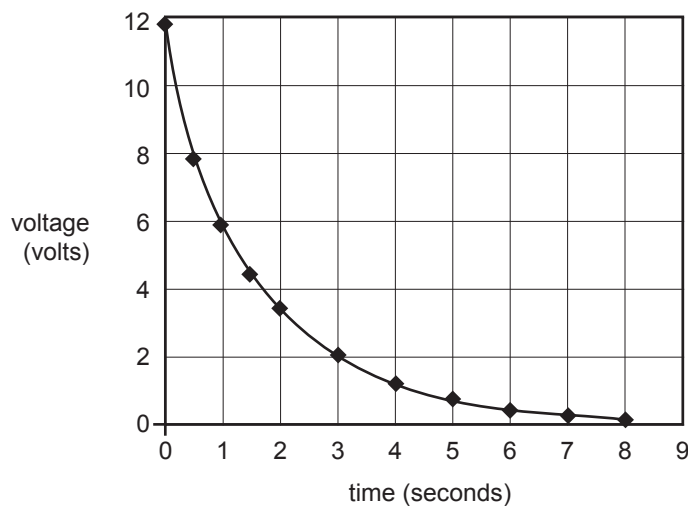

Figure 8

Question 15

- a. At what voltage reading would the deflector have to be activated?

1 mark

- b. If the delay time is to be decreased, what changes would need to be made to the resistor or capacitor?

1 mark

The process of charging and discharging a capacitor is contained within a 555 timing circuit and produces a digital output. This is shown in Figure 9 below.

parts list

R1	820 R	C1	100 μ F
R2	39 K	C2	10 nF
R3	680 Ω		

circuit diagram

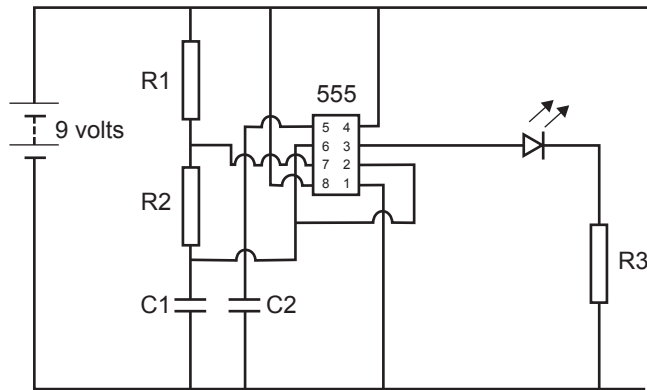

Figure 9

Question 16

The multimeter (Figure 10 below) is used to measure the voltage at several points on the circuit.

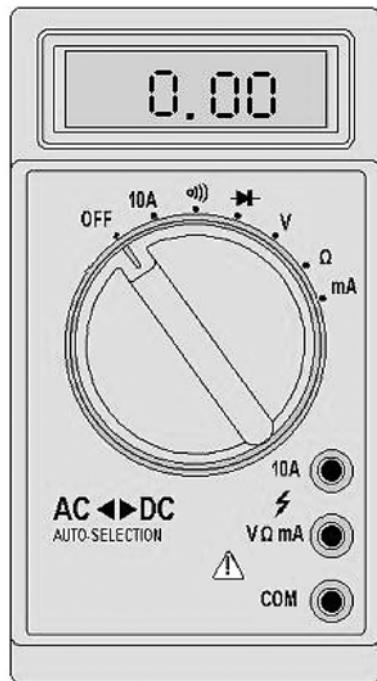

Figure 10

- a. Indicate, with an arrow on the diagram of the multimeter, where the selector dial needs to point. 1 mark
- b. Circle, on the multimeter, the socket which is not used to attach the red and black probes. 1 mark

- c. What is the expected value of the voltage between the following pairs of pins?

pins	expected voltage
1 and 8	
2 and 6	

2 marks

The light-emitting diode (LED) operates at 2.0 V and 10 mA.

- d. Calculate the voltage across the 680 Ω resistor which is in series with the LED. Show working.

2 marks



- e. Calculate the total resistance of R1 and R2. (Ignore the effects of the 555.) Show working.

2 marks

Circuitry that converts 240 VAC to a low DC is a part of most electronic appliances.

Question 17

Complete the table below for three components that can be used in a circuit to convert the 240 VAC to 12 V DC. As an example, the function and circuit symbol for a regulator are given.

component	function	symbol
e.g. regulator	maintains constant DC	
transformer		
		
	smooths DC	

3 marks

The haulage cart contains an internal combustion engine and operates on diesel fuel.

Question 18

a. Identify and explain one environmental impact resulting from the operation of the haulage cart.

2 marks

b. Suggest an alternative environmentally friendly power source to power the haulage cart.

1 mark

c. Identify one disadvantage of using the alternative suggested in **part b.** above.

1 mark

Formula sheet

Work done = force \times distance moved

Gear ratio final = gear ratio 1 \times gear ratio 2

Efficiency = $\frac{\text{output energy}}{\text{input energy}} \times 100\%$

Voltage = current \times resistance

Resistance in parallel = $\frac{R_1 \times R_2}{R_1 + R_2}$

Colour codes

Colour	Value
black	0
brown	1
red	2
orange	3
yellow	4
green	5
blue	6
violet	7
grey	8
white	9
gold	5%
silver	10%

Resistance in series = $R_1 + R_2$

$P = V \times I$

Area of circle = πr^2 ($\pi = 3.14$)

Force = pressure \times area

$\frac{\text{gear A rpm}}{\text{gear B rpm}} = \frac{\text{number of teeth gear B}}{\text{number of teeth gear A}}$

$\frac{V_{\text{in}}}{V_{\text{out}}} = \frac{N_{\text{in}}}{N_{\text{out}}}$

speed = $\frac{\text{distance}}{\text{time}}$

Gear ratio = $\frac{\text{number of teeth on driven gear}}{\text{number of teeth on driver gear}}$

