

# 2021 VCE VET Integrated Technologies external assessment report

## General comments

The 2021 VCE VET Integrated Technologies examination consisted of two sections: Section A, which comprised 20 multiple-choice questions; and Section B, which comprised 17 questions that required students to provide a combination of written explanations and show working and state the correct units of measurements for the given problems. Students needed to complete the artwork drawing of printed circuit boards, identifying the advantages and disadvantages of using different types of technology.

Although most students performed well, it was apparent that many students needed to prepare better for the examination by practising the application of Ohm's law and learning how to consistently apply engineering prefixes.

In applying Ohm's law calculations, students should follow the standard procedure, for example, in Question 2, which provided seven marks for correctly applying basic Ohm's law calculations in a purely resistive direct current (DC) circuit; Question 2a., determining the total resistance; Question 2b., determining the total current drawn; and Question 2c., finding the voltage in part of the circuit.

The students who followed the correct methodology of showing their working with correct calculations and units gained full marks for this style of question. If students made an incorrect mathematical calculation in the initial stage, it was accepted that they could use the incorrectly calculated value in the remaining questions, which are assessed as separate questions.

Students should always provide an answer, even when unsure.

It is highly recommended that students familiarise themselves with the standard table of electronic symbols as used in these examinations and published online by the VCAA.

Refer to: <https://www.vcaa.vic.edu.au/documents/vce/symbolstablew.pdf>

## Specific information

Note: This report provides sample answers, or an indication of what answers may have included. Unless otherwise stated, these are not intended to be exemplary or complete responses.

The statistics in this report may be subject to rounding resulting in a total more or less than 100 per cent.

## Section A – Multiple-choice questions

The table below indicates the percentage of students who chose each option.



Question	Correct answer	%A	%B	%C	%D	N/A	Comment
1	D	6	6	13	75	0	
2	C	0	13	81	6	0	
3	A	88	0	13	0	0	
4	C	25	31	25	19	0	Many students appeared not to be familiar with the diagram of an analogue operational amplifier (op-amp).
5	A	50	31	13	0	6	The switch was clearly a single pole single throw (SPST) having only two connections.
6	B	6	75	13	6	0	
7	D	0	0	6	94	0	
8	A	38	25	25	13	0	The clearest cause of the noise is a worn-out bearing because of the steady clicking sound produced.
9	C	0	0	94	6	0	
10	B	6	44	0	50	0	Heat sink clips are commercially available, used to sink heat away when components are soldered in.
11	D	0	6	25	69	0	
12	B	25	69	6	0	0	
13	C	6	0	63	31	0	
14	B	13	81	6	0	0	
15	D	6	31	25	38	0	The full cycle of the waveform is over 20 ms $f = 1/t = 1/20 \times 10^{-3} = 50 \text{ Hz}$
16	B	6	63	31	0	0	
17	A	63	0	6	31	0	
18	C	0	0	100	0	0	
19	B	13	38	13	38	0	The centre line is commonly shown in engineering drawings to identify the centre of a section.
20	D	0	6	6	88	0	

## Section B

### Question 1

Marks	0	1	2	3	4	5	6	Average
%	19	9	19	6	25	9	13	2.9

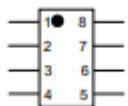
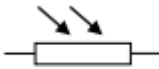
The components could be identified by their common names, and often abbreviated to just the initials as used in industry. These electronic symbols are available on the published VCCA electronic symbols standards.

Component symbol	Component name	Function or purpose of component
	Integrated circuit (IC) (Silicon) chip	<ul style="list-style-type: none"> <li>To perform some digital or analogue operation</li> <li>To integrate many components into a single device</li> </ul>
	Light dependent resistor (LDR)	<ul style="list-style-type: none"> <li>The resistance varies with the level of light falling on the resistor</li> </ul>
	Photodiode	<ul style="list-style-type: none"> <li>The conduction of the diode varies with the level of light falling on it</li> </ul>

### Question 2a.

Marks	0	1	2	3	Average
%	38	0	6	56	1.8

About one-third of the students could not solve the calculation of the total resistance. The resistor network had  $3 \times 30 \Omega$  resistors connected in parallel, together with a single  $10 \Omega$  in series with them.

$$\begin{aligned}
 1/R_T \text{ (parallel section)} &= 1/R_2 + 1/R_3 + 1/R_4 \\
 &= 1/30 + 1/30 + 1/30 \\
 &= 3/30
 \end{aligned}$$

Therefore  $R_T$  (parallel sect.) =  $10 \Omega$

$$R_{T\tau} = 10 + 10 = 20 \Omega$$

Alternatively, it could be expressed as:

$$\begin{aligned}
 R_{TT} &= 10 + (30//30//30) \\
 &= 10 + 10 \\
 &= 20 \Omega
 \end{aligned}$$

## Question 2b.

Marks	0	1	2	Average
%	28	6	66	1.4

Students were not penalised for using an incorrectly calculated resistance from Question 2a. that was subsequently used to find the current in this question if the correct method was followed.

$$\begin{aligned}
 I &= V / R \\
 &= 25 / 20 \\
 &= 1.25 \text{ A}
 \end{aligned}$$

## Question 2c.

Marks	0	1	2	Average
%	50	6	44	1.0

If the students followed the correct method to calculate the meter voltage, full marks could be awarded for consequential errors.

$$\begin{aligned}
 V &= I R \\
 &= 1.25 \times 10 \\
 &= 12.5 \text{ V}
 \end{aligned}$$

## Question 3a.

Marks	0	1	Average
%	27	73	0.8

The tool has a handle that can reach 100 mm or more directly down to the printed circuit board (PCB); the button on top is pushed down to push out the integrated circuit into the PCB location; it allows a reach into tight spaces from directly above by the user.

## Question 3b.

Marks	0	1	2	Average
%	50	6	44	1.2

A number of students incorrectly identified electrostatic discharge (ESD) as a mains power electrical safety issue, rather than some electronic components being potentially very sensitive to damage from handling in a non-safe ESD environment.

Some types of IC are particularly sensitive to ESD and must not be physically handled. Such ICs can be directly taken from the ESD protective conductive foam and held by the tool. The IC legs are physically protected until the IC is slotted into the PCB pins where it is ready for soldering in permanently.

### Question 4a.

Marks	0	1	2	Average
%	40	43	17	0.8

In this situation, it is necessary to physically disconnect one end of the component from the rest of the circuit. Caution is needed not to damage the PCB tracks through overheat when lifting and pulling one end of the component up off the PCB, so a digital multimeter (DMM) can be clipped on to the unconnected (lifted) component lead and connected to the other side of the attached component. An accurate reading can only be made when all the other extraneous circuitry is not being included in the reading.

### Question 4b.

Marks	0	1	Average
%	60	40	0.4

A static DC resistance test will indicate if the capacitor is shorted out and may also indicate that it appears to be good as it slowly charges up from the DMM supply being connected to it while testing.

### Question 5

Marks	0	1	2	3	4	5	Average
%	17	13	23	10	3	33	2.7

Some students wired the circuit with multiple short circuits; in such cases, where nothing would work, no marks were awarded. Essentially the wiring and switches must allow the fan to operate independently, and the fan must always operate whenever the heating element is on.

The preferred wiring solution is shown below.

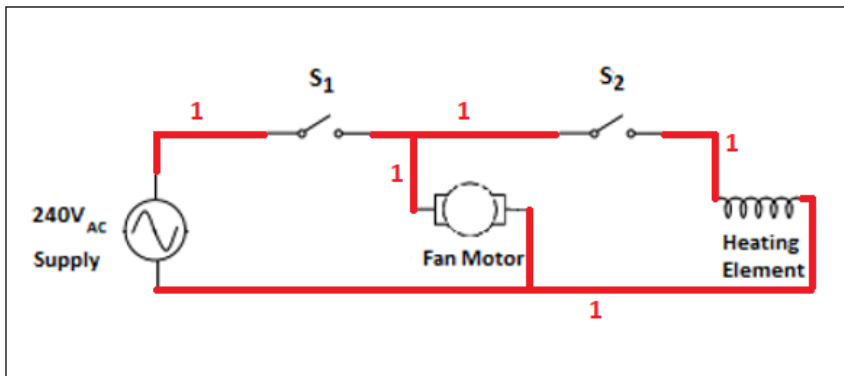

## Question 6

Marks	0	1	2	3	4	Average
%	6	6	19	44	25	2.8

Students needed to identify two relevant points for each of the fabrication stages, and the tool/s or equipment and a description of using the tool for that fabrication stage.

Fabrication stage	Name of tool and/or equipment and description of its use
marking out	Steel rule, scribe, wing divider, caliper, pen, pencil A relevant description of any one of the tools identified and how it is used in marking out the work
drilling and cutting out	High speed drill, hacksaw, metal working snips, nibbler A relevant description of some of how the tool is used in the related drilling or cutting out process This is not a conclusive list

## Question 7

Marks	0	1	2	Average
%	16	25	59	1.5

Any two recognised advantages of computer software being supplied in a download form were accepted.

Correct student responses included the following.

- Discs can be broken or damaged whereas downloads cannot.
- Downloads can be instantly accessed, whereas there is a wait for discs to arrive.
- Software updates are readily available.
- It's cheaper and more efficient for the software vendor, as not required to package and send discs.
- It's better for the environment as physical products do not have to be made and distributed.
- Lack of disc drives in newer devices.

## Question 8

Marks	0	1	2	Average
%	9	44	47	1.4

Any two reasonable reasons why regular shutdowns or restarts of a computer should be done were accepted.

Correct student responses included the following.

- Software updates need a restart in order to run properly.
- Changing of wi-fi networks between work and home – the computer needs a reboot.
- Shutting down the computer saves power.
- The RAM is cleared allowing the computer to run faster.
- Leaving the computer running for long periods shortens the lifespan of the device.
- While low risk, the potential for fire is increased when the computer is just left running.

## Question 9

Marks	0	1	2	3	Average
%	47	16	25	13	1.1

The students appeared to struggle to identify three different pieces of information.

Correct responses included:

- scale
- part name
- drawing author
- projection view (first or third angle)
- date
- drawing number
- revision number
- design company / group and logo.

## Question 10a.

Marks	0	1	Average
%	6	94	0.9

The only acceptable answer was millimetres (mm).

The majority of students got this answer correct.

## Question 10b.

Marks	0	1	2	Average
%	6	66	28	1.2

The two missing dimensions were:

- the overall length or the distance between the centres
- the hole size to be drilled.

As the thickness of the sheet had been given as 12 gauge (2.05 mm), this was not accepted.

## Question 11

Marks	0	1	Average
%	29	71	0.7

Correct common responses were:

- Fusion 360
- SketchUp
- Solidworks
- SolidEdge
- Illustrator
- Corel Draw

- AutoCAD
- Et
- AI

This is not a comprehensive list. Responses such as 'Paint' were not accepted.

## Question 12a.

Marks	0	1	2	Average
%	35	26	39	1.1

Auto-routing is the process where the PCB design software intelligently and automatically decides which would be the best and most space-efficient route to run the tracks to interconnect the various components on the PCB being designed.

## Question 12b.

Marks	0	1	2	Average
%	32	13	55	1.3

Common correct responses were:

- when applied it is time saving
- greatly increasing efficiency of the process
- a circuit diagram can be taken and directly converted to a PCB layout using the auto-routing software where the best available options are automatically done
- automatic checking of errors being undertaken.

## Question 12c.

Marks	0	1	2	Average
%	39	39	23	0.8

The following are occasions where the auto-routing function may not be used. This is not a comprehensive list.

- To allow the user to manually place components on the edge of the PCB such as for ports and connectors.
- In complex or RF circuits, the solution could cause problems because of unrealistically long track paths (e.g. the transfer of signals).
- Thermal distribution issues are not usually considered by the auto routing software.
- Higher current tracks that need to be much thicker.

## Question 13

Refer to the correct answers as provided in the PCB artwork following.



### Question 13a.

Marks	0	1	2	Average
%	19	0	81	1.7

### Question 13b.

Marks	0	1	Average
%	68	32	0.3

### Question 13c.

Marks	0	1	2	Average
%	13	29	58	1.5

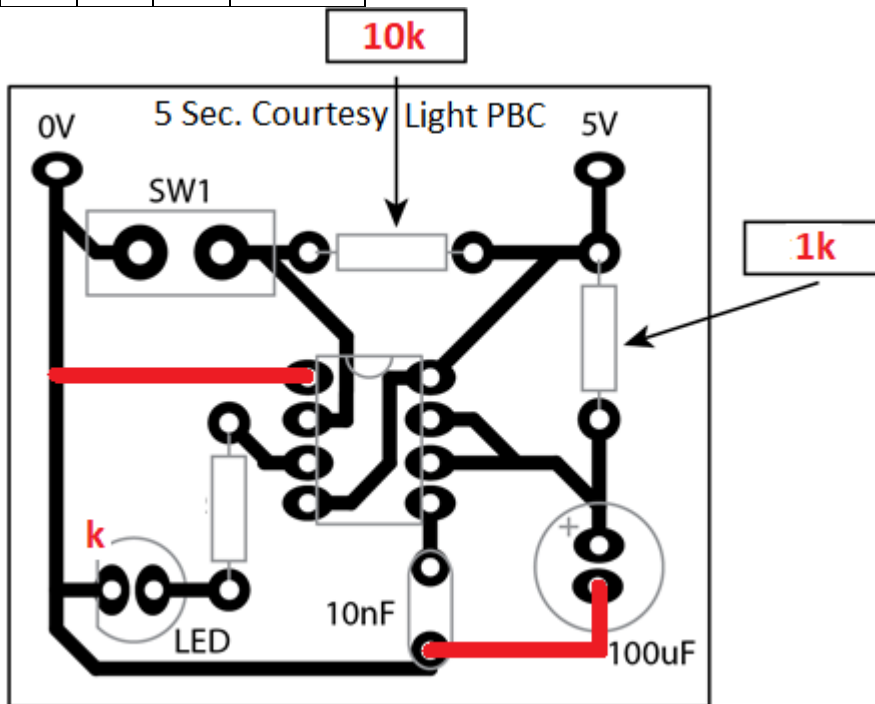

## Question 14ai.

Marks	0	1	2	3	Average
%	6	13	16	65	2.4

Voltmeters	Voltage determined
$V_1$	30 V
$V_2$	15 V
$V_3$	15 V

## Question 14aii.

Marks	0	1	Average
%	35	65	0.7

Ammeters	Current determined
$A_1$	1 A
$A_2$	1 A

## Question 14bi.

Marks	0	1	Average
%	55	45	0.5

The faulty component was  $R_2$ .

## Question 14bii.

Marks	0	1	2	3	Average
%	61	6	13	13	0.9

The fault was a short-circuited resistor.  $V_1$  and  $V_2$  are showing the full supply of 30 V, while  $V_3$  is showing 0 V. Also, the current had doubled from 1 A to 2 A, indicating that only 15  $\Omega$  in the circuit, so  $R_2$  is effectively shorted out in the circuit.

## Question 15ai.

Marks	0	1	2	Average
%	45	23	32	0.9

The response needed to state the internal wires are fully wrapped and enclosed and identify the purpose of shielding as reducing or stopping interference. Shielded wire is where the internal conducting wires are fully wrapped around the outside by a braided or foil insulation. The shielding conductor is commonly earthed, which stops other external signals being induced into the conducting wires.

## Question 15aii.

Marks	0	1	Average
%	55	45	0.5

Any common shielded cable could be given. Examples of a specific type of cable/wire that is shielded are:

- TV co-axial cable
- Apple lightning cable
- wired ear buds cable
- laptop power cable
- Optus network cables run on the street power poles.

This is not an exhaustive list.

## Question 15b.

Marks	0	1	2	Average
%	42	26	32	1.0

Two benefits of using shielded multi-strand wire in vending machines are:

- The multistrand wire is very flexible and therefore can be run in corners and through tight positions where it may be subject to bending and twisting.
- The multistrand wire is less inclined to snap or break with vibrations and any movement of the vending machine.

This is not an exhaustive list.

## Question 15c.

Marks	0	1	Average
%	10	90	0.9

Conducting wire material is usually made from copper.

## Question 15di.

Marks	0	1	Average
%	10	90	0.9

Students commonly identified wire stripping tools as:

- combination wire strippers
- wiring stripping tool
- side cutting pliers
- combination pliers
- knife.

This is not an exhaustive list of tools.

## Question 15dii.

Marks	0	1	2	Average
%	3	3	94	1.9

The description varied with the stripping tool identified. Depending on the types of wire or cable being used the level of caution needs to be taken. Solid wire is the easiest to strip, whereas fine multistrand wire is more difficult. The insulation needs to be nicked by to tool without cutting into the wire stands. Some tools do this well while others, such as side-cutting pliers, may need to manually nick the insulation and break it, prior to pulling off the insulation.

This question was well answered.

## Question 15e.

Marks	0	1	Average
%	71	29	0.3

This is a pull-down resistor, as the resistor is 'tied to ground' (0 V). The function of the resistor is to maintain the output of the coin acceptor module and input to the microprocessor in a low state, not allowing it to 'float high'.

## Question 15f.

Marks	0	1	Average
%	19	81	0.8

The generated pulses measured in milliseconds: 50 ms.

### Question 15g.

Marks	0	1	Average
%	42	58	0.6

The correct response was an oscilloscope or cathode-ray oscilloscope (CRO) or a similar device that can produce a waveform image.

### Question 16a.

Marks	0	1	2	Average
%	13	17	70	1.6

IC pin numbering is shown below.

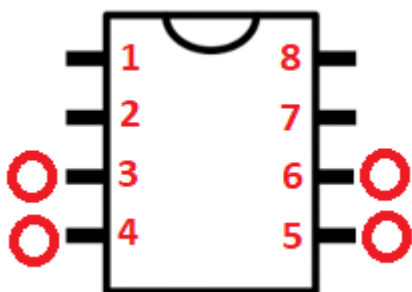

### Question 16b.

Marks	0	1	Average
%	43	57	0.6

Pin number 3, 4, 5 or 6 could be selected as shown above. Many students identified pin 2 (serial in) incorrectly.

### Question 16c.

Marks	0	1	2	Average
%	27	20	53	1.3

The purpose of the Voltage Common Collector (VCC) is to provide a positive power supply connection on the IC; this is directly connected to the + connection of the DC supply rails.

The IC needs to have a power connection and VCC is identified as the positive supply connection, which would be directly wired up to the supply rails with typically 3.3 to 15 V DC range depending on the circuit design.

### Question 17a.

Marks	0	1	2	Average
%	0	3	97	2.0

The decision box squares are labelled Y (Yes) and N (No) (see diagram below).

### Question 17b.

Marks	0	1	Average
%	90	10	0.2

A time between 51 ms to 99 ms inclusive was acceptable.

Many students incorrectly responded 50 ms, potentially resulting in a faulty reading.

### Question 17c.

Marks	0	1	2	Average
%	33	7	60	1.2

The return line would commonly return to just above the decision box; some students returned it to the decision box, which was also accepted, as shown below.

