

SUPERVISOR TO ATTACH
PROCESSING LABEL HERE

--	--	--	--	--	--	--	--	--

Write your **student number** in the boxes above.

Letter

VET Furnishing

Question and Answer Book

VCE Examination – Thursday 6 November 2025

- Reading time is **15 minutes**: 9.00 am to 9.15 am
- Writing time is **1 hour 30 minutes**: 9.15 am to 10.45 am

Materials supplied

- Question and Answer Book of 28 pages
- Detachable Insert for Section C in the centrefold
- Multiple-Choice Answer Sheet

Approved materials

- One scientific calculator

Instructions

- Follow the instructions on your Multiple-Choice Answer Sheet.
- At the end of the examination, place your Multiple-Choice Answer Sheet inside the front cover of this book.
- Detach the Insert for Section C from the centre of this book during reading time.

Students are **not** permitted to bring mobile phones and/or any unauthorised electronic devices into the examination room.

Contents	pages
Section A (20 questions, 20 marks) _____	2–9
Section B (15 questions, 43 marks) _____	10–18
Section C (10 questions, 37 marks) _____	20–27

Section A – Multiple-choice questions

Instructions

- Answer **all** questions in pencil on your Multiple-Choice Answer Sheet.
 - Choose the response that is **correct** or that **best answers** the question.
 - A correct answer scores 1; an incorrect answer scores 0.
 - Marks will **not** be deducted for incorrect answers.
 - No marks will be given if more than one answer is completed for any question.
 - Unless otherwise indicated, the diagrams in this book are **not** drawn to scale.
-

Question 1

What does CAD stand for?

- A. computer-automated drawing
- B. computer-added drafting
- C. computer-aided design
- D. computer-AI drawing

Question 2

Ramesh is employed as a draftsman in a furniture company that makes dining tables.

What is one advantage Ramesh gains by using CAD software to make drawing easier?

- A. CAD promotes hands-on creativity.
- B. It is easy to change measurements.
- C. It is easy to learn all of CAD's functions.
- D. He can print a full-size scale drawing on A4 paper.

Question 3

Which unit of measurement is used when producing scaled working drawings for a furniture project?

- A. inches
- B. millimetres
- C. metres
- D. centimetres

Question 4

The drawing below shows a section of a frame and panel door.

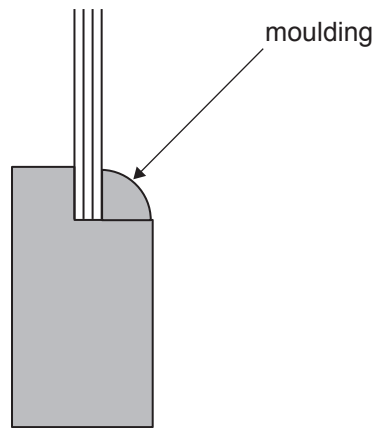

Which type of moulding would be used to hold a loose panel for the frame and panel door of a bedside cabinet, where the moulding does not stick out past the face?

- A. bolection moulding
- B. insertion moulding
- C. dado moulding
- D. cornice moulding

Question 5

Anika is making 16 dining tables from solid wormy chestnut timber. She has joined the timber for the tabletops and put them aside, leaving the glue to cure and the moisture content in the timber to equalise, while she makes the leg and rail assemblies.

What should Anika do with the tabletops when she has removed them from the clamps?

- A. Lean them up against a wall.
- B. Lay them flat on a cold concrete floor.
- C. Place them on an undersized mobile trolley.
- D. Place them on bearers with sticks between them.

Question 6

How many front legs, back legs and front rails are required to make four Captain's Chairs?

	Front legs	Back legs	Front rails
A.	4	4	2
B.	6	6	4
C.	8	8	4
D.	7	7	4

Do not write in this area.

Question 7

The image below shows a wire brush.



What is the function of a wire brush in a workshop?

- A. to remove deep rust from a chisel
- B. to clean a grinding wheel
- C. to clean a panel saw
- D. to remove dust from a file

Question 8

A drawing of a kitchen bench and overhead cabinets is shown below.

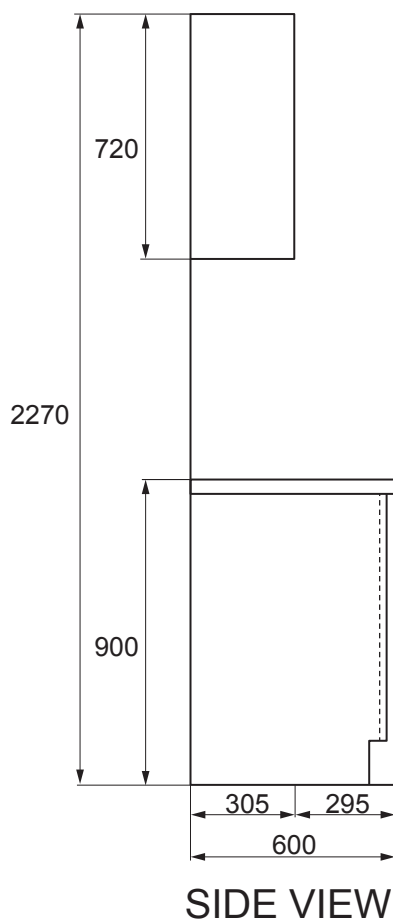

A splashback will be installed between the benchtop and the bottom of the overhead cabinets.

What is the height of the splashback?

- A. 530 mm
- B. 550 mm
- C. 650 mm
- D. 690 mm

Question 9

Which one of the following timbers is less likely to cup, twist and wind?

- A. quartersawn
- B. back-sawn
- C. wavy grain
- D. fiddleback

Question 10

Samantha notices that a hole has been cut into the plastic casing of the belt sander cord.

What should Samantha do?

- A. Swap the belt sander for another sander.
- B. Put electrical tape over the hole.
- C. Continue to use the belt sander and not tell anyone.
- D. Stop using the belt sander and take it to her supervisor.

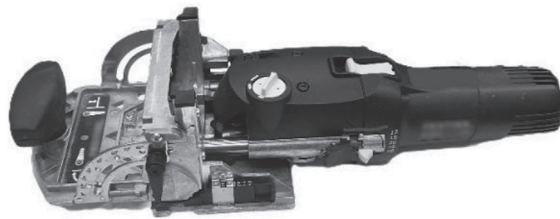
Question 11

The Domino machine shown in the image above is used to

- A. cut a hole, recess or mortise.
- B. finely cut or sand surfaces.
- C. make concave cuts for biscuit joints.
- D. cut a lapped dovetail in a drawer front.

Question 12

When drawing a full-size set-out, a furniture-maker should

- A. draw the set-out 1:1.
- B. draw the set-out 1:5.
- C. place sticky notes on the set-out to show the measurements.
- D. use a tape measure to draw all lines and dimensions.

Question 13

Which guidance should be followed to ensure the maximum amount of adjustment for concealed hinges?

- A. instructions from colleagues
- B. workplace lean procedures
- C. manufacturers' specifications
- D. Australian Standard AS 4386:2018

Question 14

The drawing below shows a section of a drawer.

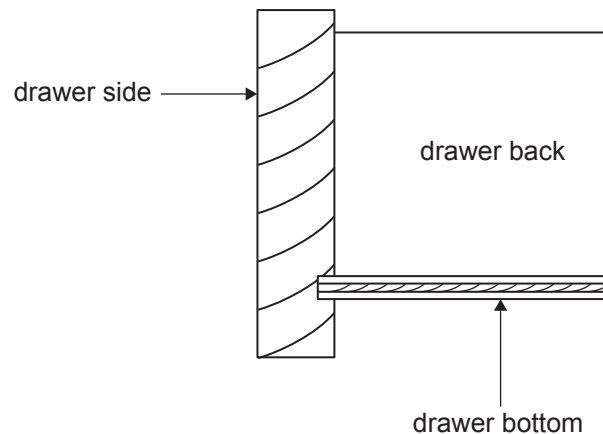

Which fasteners should be used when fastening the drawer bottom to the bottom edge of the drawer back?

- A. small bullet head nails
- B. galvanised clouts
- C. knockdown fittings
- D. small flathead nails

Question 15

The image below shows a size 32 forstner bit.



What does the size refer to?

- A. the length of the shank
- B. the radius of the cutting edge
- C. the diameter of the cutting edge
- D. the date when the tool was manufactured

Question 16

Which joint should be used to join the bottom panel of melamine modular kitchen cabinets to the end panel?

- A. finger or box joint
- B. screwed butt joint
- C. through mortise and tenon joint
- D. secret dovetail mitre joint

Question 17

Geoffrey is drawing a full-size set-out on brown kraft paper on a timber drawing board.

Which piece of equipment should Geoffrey use to accurately draw horizontal lines across the paper?

- A. T square
- B. metre ruler
- C. tape measure
- D. 30–60° set square

Question 18

The drawing below shows a tabletop comprising timber pieces that have been glued together in a way that eliminates timber defects.

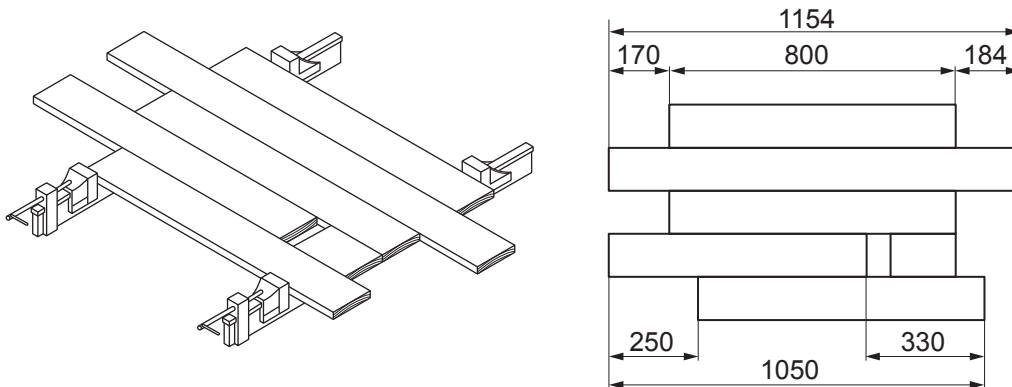

TOP VIEW

Which one of the following gives the length of the rectangular tabletop?

- A. 330 mm
- B. 470 mm
- C. 800 mm
- D. 1154 mm

Question 19

Which one of the following would **not** be part of the quality control process for selecting raw materials when making a piece of furniture?

- A. checking the quantity
- B. checking the specifications
- C. checking the quality of raw materials
- D. checking the machine maintenance log

Question 20

Imani is about to select timber to manufacture a freestanding writing desk and chair. The building in which the desk and chair will be located is climate controlled with central heating and cooling.

Which one of the following gives the preferred range for the moisture content of the timber Imani should select?

- A. 9–14%
- B. 15–19%
- C. 20–25%
- D. 26–30%

Do not write in this area.

Section B

Instructions

- Answer **all** questions in the spaces provided.
 - Write your responses in English.
 - Unless otherwise indicated, the diagrams in this book are **not** drawn to scale.
-

Question 1 (2 marks)

Jeremy is about to mark out the boards for the top of a writing desk using dowels as a widening joint. The top has three boards with two joins.

- a. Name the hand tool that Jeremy will use to mark the horizontal centre line of the dowels on the edge of the boards. 1 mark

- b. Describe how Jeremy should use the hand tool named in **part a** to complete the task. 1 mark

Question 2 (2 marks)

For safety and to be able to cut properly, the blade in a circular saw is required to rotate in a certain direction.

In the space provided below, sketch the blade of a circular saw, including its teeth, and add an arrow showing the correct rotation.



Question 3 (2 marks)

Hwan is attaching the top of a coffee table to the frame. He flips the tabletop upside down onto the workbench, then flips the frame and places it on the top, ensuring an even overhang. He then uses F clamps to hold the frame and top together before screwing them in place.

Provide two reasons why Hwan clamps the frame and top together before screwing them in place.

Reason 1 _____

Reason 2 _____

Question 4 (4 marks)

The tabletop shown below consists of two half circles and a rectangle. The formula for calculating the area (A) of a circle is: $A = \pi r^2$

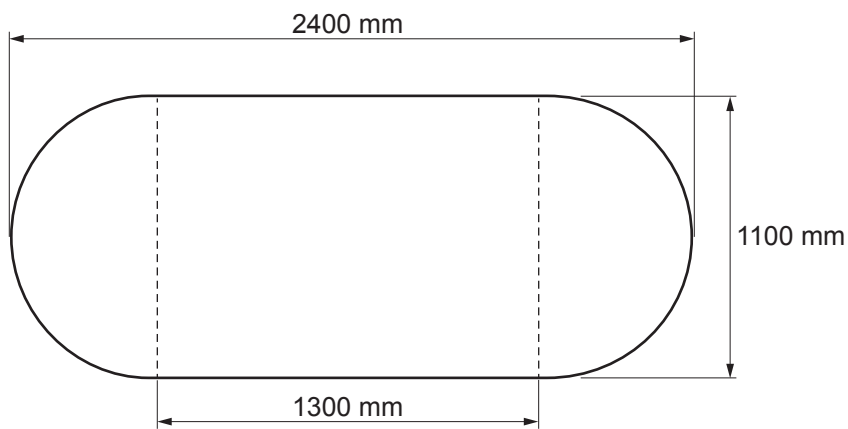

Calculate the total surface area of the tabletop in square metres (m^2), correct to three decimal places. Show your working in the space provided below.

Surface area of the tabletop:

Do not write in this area.

Question 5 (3 marks)

Ash is preparing to finish four chairs that she has made. During the sanding process, she noticed a few small dents in some of the components.

- a. Name **one** method, other than filling or sanding, that Ash could use to repair the dents. 1 mark

- b. Explain how the method named in **part a** should be used. 2 marks

Question 6 (3 marks)

The drawing below shows an end frame of a table.

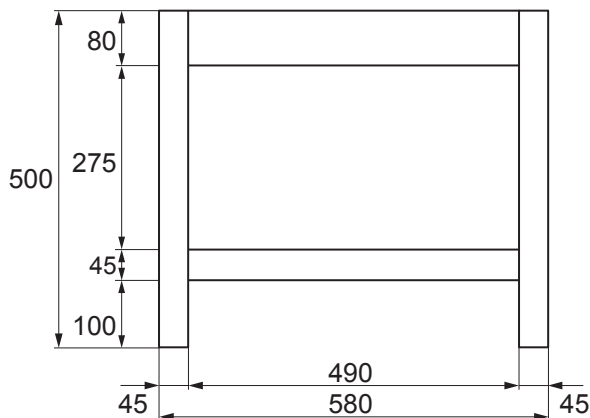

When gluing a leg and rail frame together, what type of clamp is most suitable to use?
 Give one reason for your response.

Clamp _____

Reason _____

Question 7 (2 marks)

What are two uses for the claws on the back of a claw hammer?

Use 1 _____

Use 2 _____

Question 8 (2 marks)

Nathan received a delivery of flat pack cabinets. The items came in three large cardboard boxes, packed with polystyrene spacers.

What should Nathan do with the packaging materials once he has assembled the cabinets?

Question 9 (2 marks)

Frankie is making six chairs using Tasmanian oak. The joints will be constructed using loose tenons. She is about to cut the top front rails on a drop saw. The width of the chairs at the front is 570 mm and the width of each leg is 45 mm.

a. What length will Frankie need to cut the rails to? 1 mark

b. How many lineal metres will she need for six rails? 1 mark

Question 10 (3 marks)

Yuusuf is making a serpentine fronted cabinet. The cabinet has one long drawer and one laminated plywood door with a decorative timber veneer finish. An example of this cabinet is shown in the image below.



The drawer front will be made from solid timber faced with the same decorative veneer as the plywood door. The solid timber needs to be cut along the long grain for strength.

The drawer front measures 600 mm × 130 mm with a finished thickness of 20 mm.

On the drawing below, show how Yuusuf should economically produce the drawer front using three pieces of timber, each with a sectional size of 140 mm × 50 mm.

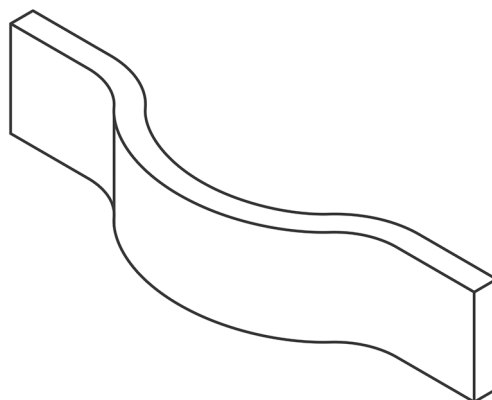

drawer front

Question 11 (4 marks)

Simone is designing and making a hall table that has cylindrical legs. She is considering how she should join the rails at the tops of all four legs. She is wondering whether she should shape the rails to the legs or shape the legs to the rails.

- a. On the diagram below, draw how Simone could shape the rails to the legs. 1 mark

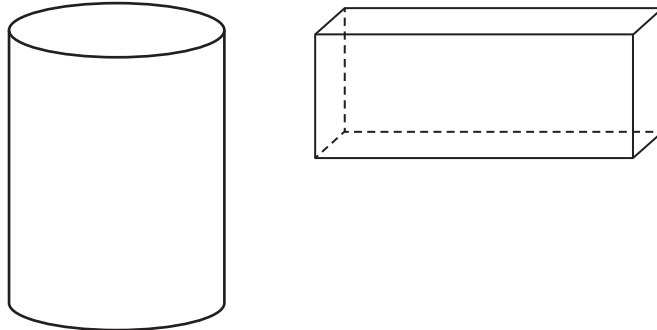

- b. On the diagram below, draw how Simone could shape the legs to the rails. 1 mark

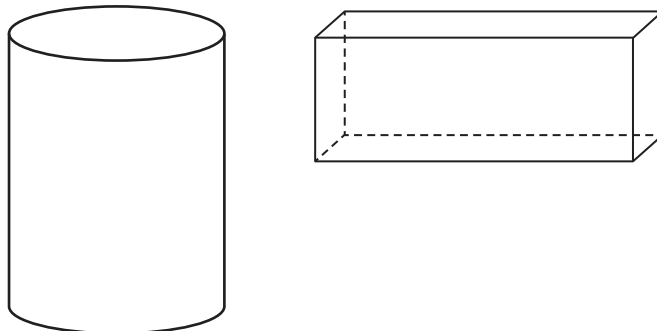

- c. Which of the two joints – **part a** or **part b** – is stronger? Justify your response. 2 marks

Question 12 (2 marks)

Describe a technique that should be used to ensure that the correct amount of polyvinyl acetate (PVA) glue has been put into dowel holes.

Do not write in this area.

Question 13 (3 marks)

The diagram below shows the underneath view of a dining table, showing the stretcher rails and the span rails.

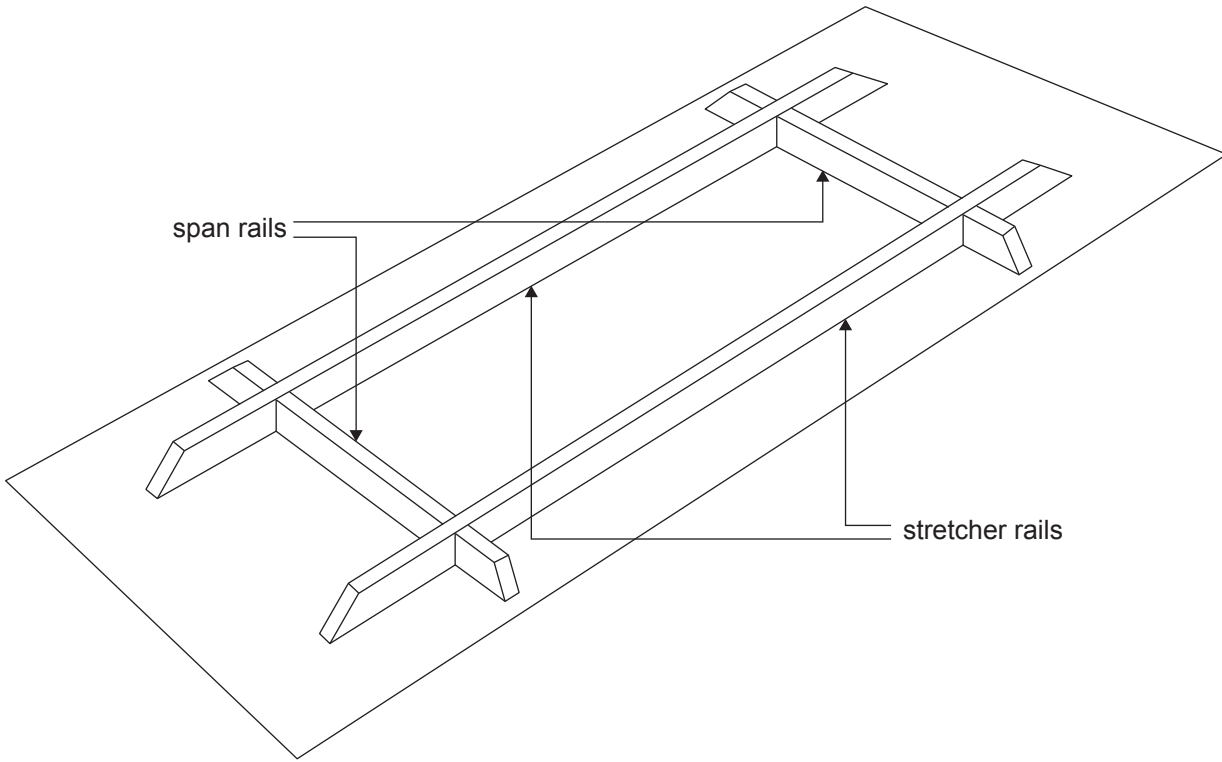

- a. Name the strongest joint for the intersections of the stretcher rails and the span rails on this dining table.

1 mark

- b. On the diagram below, draw the type of joint that you have named in **part a**.

2 marks

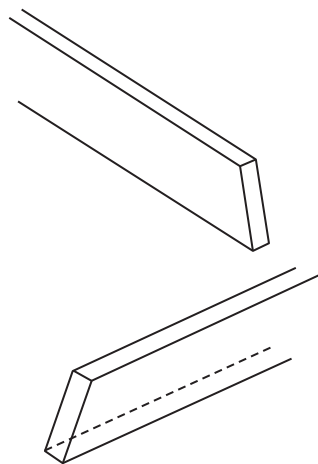

Question 14 (6 marks)

Marcus is making an outdoor sun lounge, shown in the drawing below. When it is finished, he will need to transport the sun lounge home in his van.

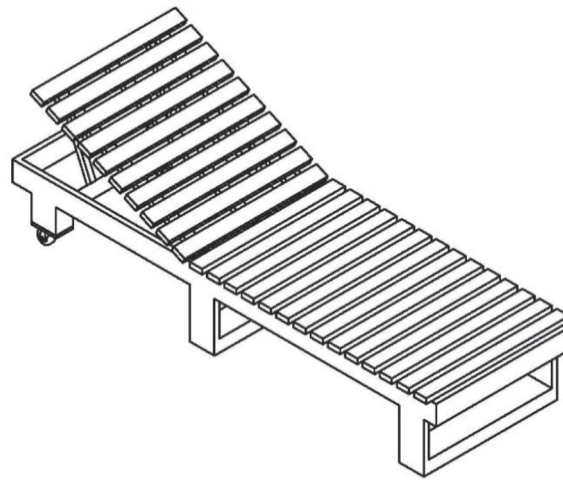

- a.** For visual appeal Marcus needs to make sure that each slat is evenly spaced and has the same amount of overhang on each side.

List two tools and/or pieces of equipment that can be used to ensure an even spacing and overhang is achieved.

2 marks

- _____
- _____

- b.** Select **one** tool or piece of equipment from your response to **part a** and explain how Marcus should use it to achieve an even spacing and overhang.

1 mark

- c.** What are the three measurements of the sun lounge that Marcus needs to check to make sure it will fit in his van?

3 marks

- _____
- _____
- _____

Do not write in this area.

Question 15 (3 marks)

Harshani is making six lamp tables. One lamp table is shown in the drawing below.

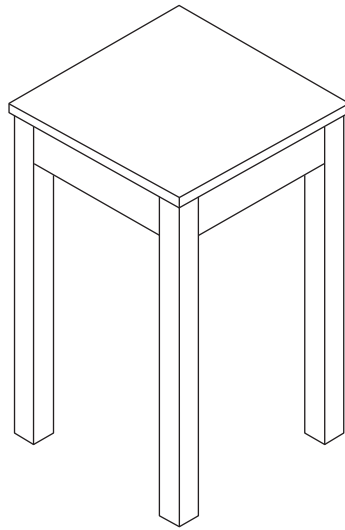
**Specifications**

- Each table measures 450 mm × 450 mm and is 720 mm high, with rails on all four faces.
- The tops are 450 mm square and are made from 150 mm × 20 mm dressed all round (DAR) Victorian blackwood.
- The legs are 700 mm × 45 mm × 45 mm.
- The rails are 336 mm × 90 mm × 20 mm.

Calculate the dimensions and lineal metres required for each of the table's three components, correct to three decimal places.

Component	Dimensions	Lineal metres
top		
leg		
rail		

Do not write in this area.

This page is blank.

Examination continues on the next page.

Section C – Case study

Instructions

- Please remove the Insert from the centre of this book during reading time.
 - Use the specifications provided below and the working drawings in the Insert to answer the questions in this section.
 - Use explanatory diagrams, charts and sketches if you believe they will improve your answers.
 - Answer **all** questions in the spaces provided.
 - Write your responses in English.
 - Unless otherwise indicated, the diagrams in this book are **not** drawn to scale.
-

Read the following specifications together with the working drawings on pages 2 and 3 of the Insert.

Specifications

A client requires a credenza for their office, with the following specifications.

Dimensions: 1835 mm × 851 mm × 500 mm

Finish: 70% gloss pre-catalysed lacquer, sprayed application

Materials

- 19 mm Queensland maple veneered particle board (VPB)
- 125 mm × 25 mm Queensland maple solid timber
- 65 mm × 65 mm Queensland maple solid timber
- 4 mm Queensland maple veneered plywood (good on one face)
- 200 mm × 12 mm Victorian ash
- 1.5 mm rattan panel
- 6 mm cane

Carcase

- made from 19 mm Queensland maple VPB
- 19 mm × 25 mm solid edging – front edge of top panel, bottom panel, end panels and divisions, attached using a tongue and groove
- carcass corners – all four corners mitred, aligned and strengthened by three biscuits in each corner
- three divisions – biscuited into the top and bottom panels using three biscuits in each end, with the division on the right supporting the drawer runners
- adjustable shelves – fitted with support pins
- front and back biscuits – 100 mm from the outer edge to the centre of the biscuit, and the third placed in the centre of the width of the panel
- back panel – one piece of 4 mm Queensland maple veneered plywood attached using narrow crown staples, rebated all round with a 13 mm × 4 mm rebate
- legs – one central, four external, with a taper of 60 mm down to 40 mm
- external legs – tapered and angled both top and bottom to accommodate being splayed on the carcass

Door

- doorframe – Queensland maple solid timber, with the stiles, top rail and bottom rail all machined to 75 mm × 19 mm
- rattan panel – set into a 6 mm × 6 mm groove and held in position by a 6 mm cane spline, with one mitred joint on the spline located at the bottom centre of the width of the door
- hung using two 107° concealed hinges

Drawers

- drawer fronts, sides and backs – 12 mm Victorian ash, with a 5 mm × 4 mm groove 10 mm up from the bottom edge on the inside face of all pieces
- drawer bottoms – 4 mm Queensland maple veneered plywood
- false drawer fronts – Queensland maple VPB, edged with an iron-on veneer edging
- soft-close mechanical drawer runners – fitted to the centre of each side of the drawers

Question 1 (5 marks)

Complete the table below by filling in the missing information in the bold boxes using the working drawings and specifications.

Cutting list							
Item no.	Item name	No. of pieces	Length (mm)	Width (mm)	Thickness (mm)	Remarks	Material
Carcase							
1.	top	1	1835	500	19	solid front edged	Queensland (Qld) maple VPB
2.	bottom	1		500	19	solid front edged	Qld maple VPB
3.	end	2	600	500	19	solid front edged	Qld maple VPB
4.	division	3	562	458	19	solid front edged	Qld maple VPB
5.	back panel	1	1823	588		fits in rebate	Qld maple veneered plywood
6.	adjustable shelf	3	431	457	19	solid front edged	
7.	solid edging	2	1835	25	19	machined with tongue	Qld maple
8.	solid edging	2	600	25	19	machined with tongue	Qld maple
9.	solid edging	3	562	25	19	machined with tongue	Qld maple
10.	solid edging	3	431	25	19	machined with tongue	
11.	leg	5	285	60	60	tapered	Qld maple
Door							
12.	stile	2	558	75	19	dressed all round (DAR)	Qld maple
13.	top rail	1	283	75	19	DAR	Qld maple
14.	bottom rail	1	283	75	19	DAR	Qld maple
15.	rattan	1	600	500	1.5	soak in water	rattan
16.	spline	1	1600	6	6	soak in water	cane

Cutting list							
Item no.	Item name	No. of pieces	Length (mm)	Width (mm)	Thickness (mm)	Remarks	Material
Drawers							
17.	false front	3	433	185	19	iron on pre-glued edge	Qld maple VPB
18.	front	3	391		12	machine dovetailed to sides	Victorian ash
19.	back	3	379	171	12	housed to sides	Victorian ash
20.	side	6	472	185	12	dovetailed at front, housed at back	Victorian ash
21.	bottom	3	413	465	4	sits in 5 mm × 4 mm groove	Qld maple veneered plywood

Question 2 (3 marks)

During the design phase of making the credenza, it is best practice to either draw the project full-size on brown kraft paper or create an orthographic drawing using CAD.

List three views that will provide the greatest amount of relevant information.

- _____
- _____
- _____

Question 3 (3 marks)

You are drawing a full-size set-out of the credenza. After drawing the ground line, you wonder how you can accurately draw the vertical lines at 90°.

- a. Identify the best equipment to use to accurately draw the vertical lines at 90°. 1 mark

- b. Describe how the equipment identified in **part a** should be used. 2 marks

Question 4 (7 marks)

The credenza has a framed timber door that is decorated with rattan. The rattan is glued with polyvinyl acetate (PVA) and inserted into a groove that has been machined into the face of the door.

- a. How will the rattan be held in place? 1 mark

- b. What power tool will you use to prepare for the rattan? 1 mark

- c. Describe how you will set the depth of the power tool identified in **part b**. 2 marks

- d. Name two items of personal protective equipment (PPE) required when using the power tool named in **part b**. 2 marks

- _____
- _____

- e. What piece of equipment will you use to secure the door while machining? 1 mark

Question 5 (3 marks)

When biscuits are being cut, dust can become a hazard to people in a workshop environment.

Identify three risks of dust in a workshop.

- _____
- _____
- _____

Question 6 (3 marks)

The legs on the credenza will be tapered and angled at the top and bottom.

- a. Which should be machined first – the angle or the taper? Justify your response. 1 mark

- b. Describe the set-up of the power tool you will use to cut the top and bottom of the legs. 2 marks

Question 7 (4 marks)

- a. What type of hinge is used on the credenza door? 1 mark

- b. In the table below, describe the three missing steps in setting out and drilling the cup holes for the hinges on the door. 3 marks

Step no.	Description of step
1.	<i>Mark out the height of the hinges on the door.</i>
2.	
3.	
4.	
5.	<i>With the forstner bit in the pedestal drill, drill the holes.</i>

Question 8 (4 marks)

The drawer bottoms and carcass back panel for the credenza are cut from Queensland maple veneered plywood. The plywood is constructed using three layers or plies of veneer or thin timber.

- a. On the diagram provided below, show the main characteristics of the grain of the veneers. 3 marks

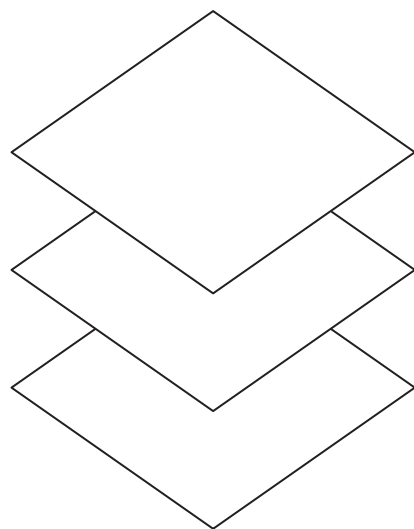

- b. Explain why the characteristics shown in **part a** are important for plywood. 1 mark

Do not write in this area.

Question 9 (2 marks)

The carcass of the credenza is made from VPB.

What other commonly used 19 mm manufactured board could you use as an alternative?
Justify your response.

Question 10 (3 marks)

The client is considering changing the credenza design to have five equal divided spaces instead of four equal divided spaces.

For this scenario, provide the internal measurements for each of the five equal divided spaces. Use a drawing in the space below to show your working and measurements.

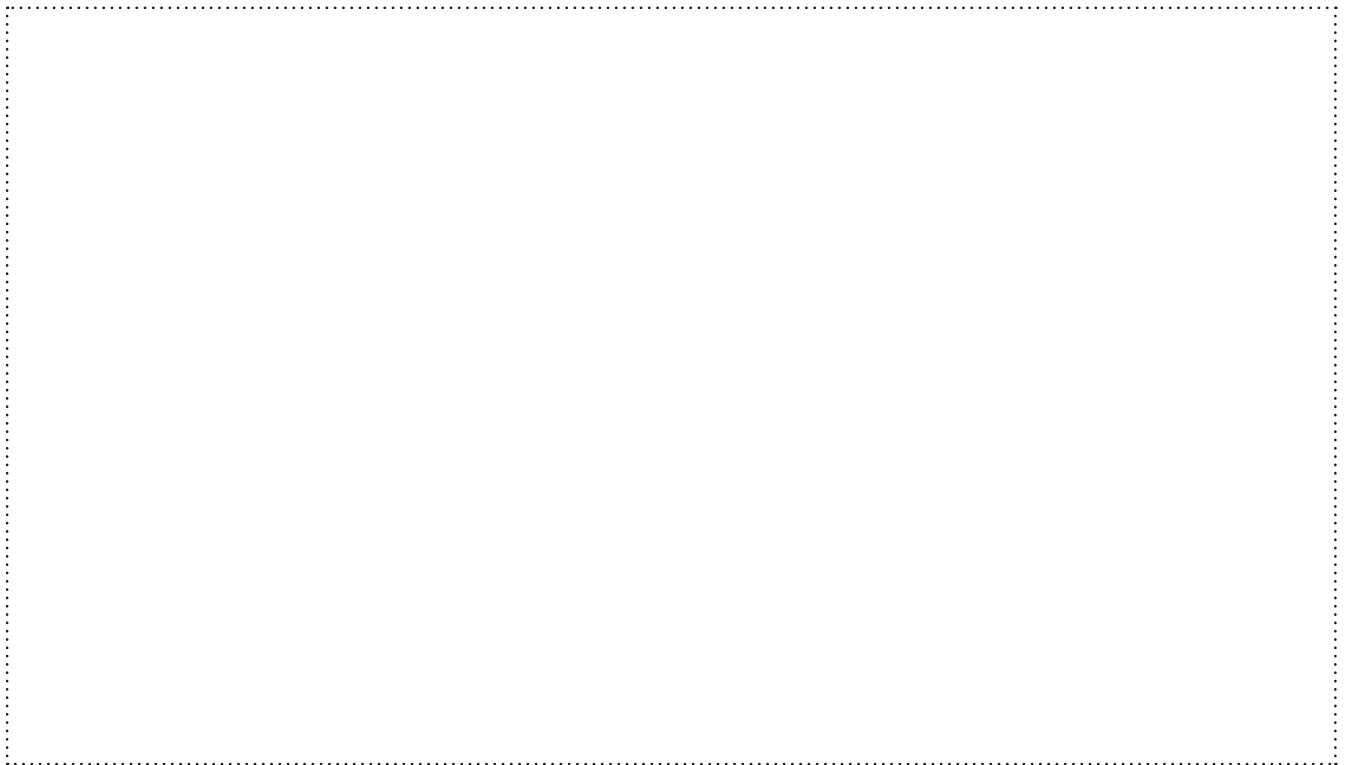

Do not write in this area.

VET Furnishing

Insert for Section C

Please remove from the centre of this book during reading time.

You may keep this Insert.

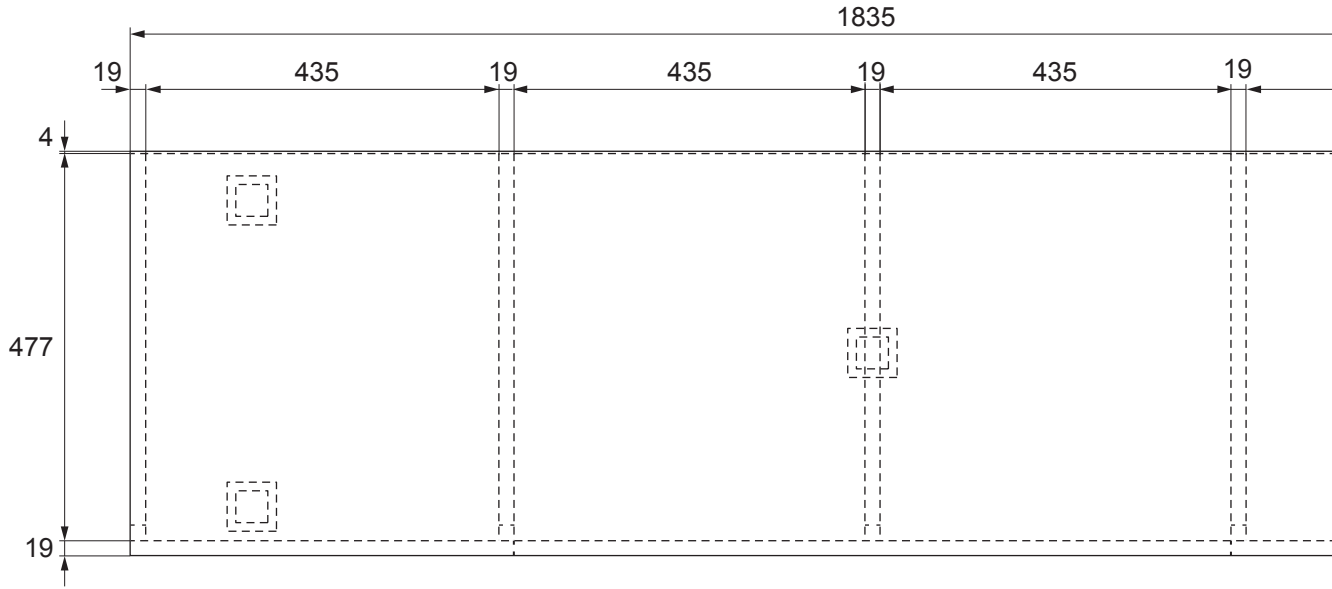

TOP VIEW

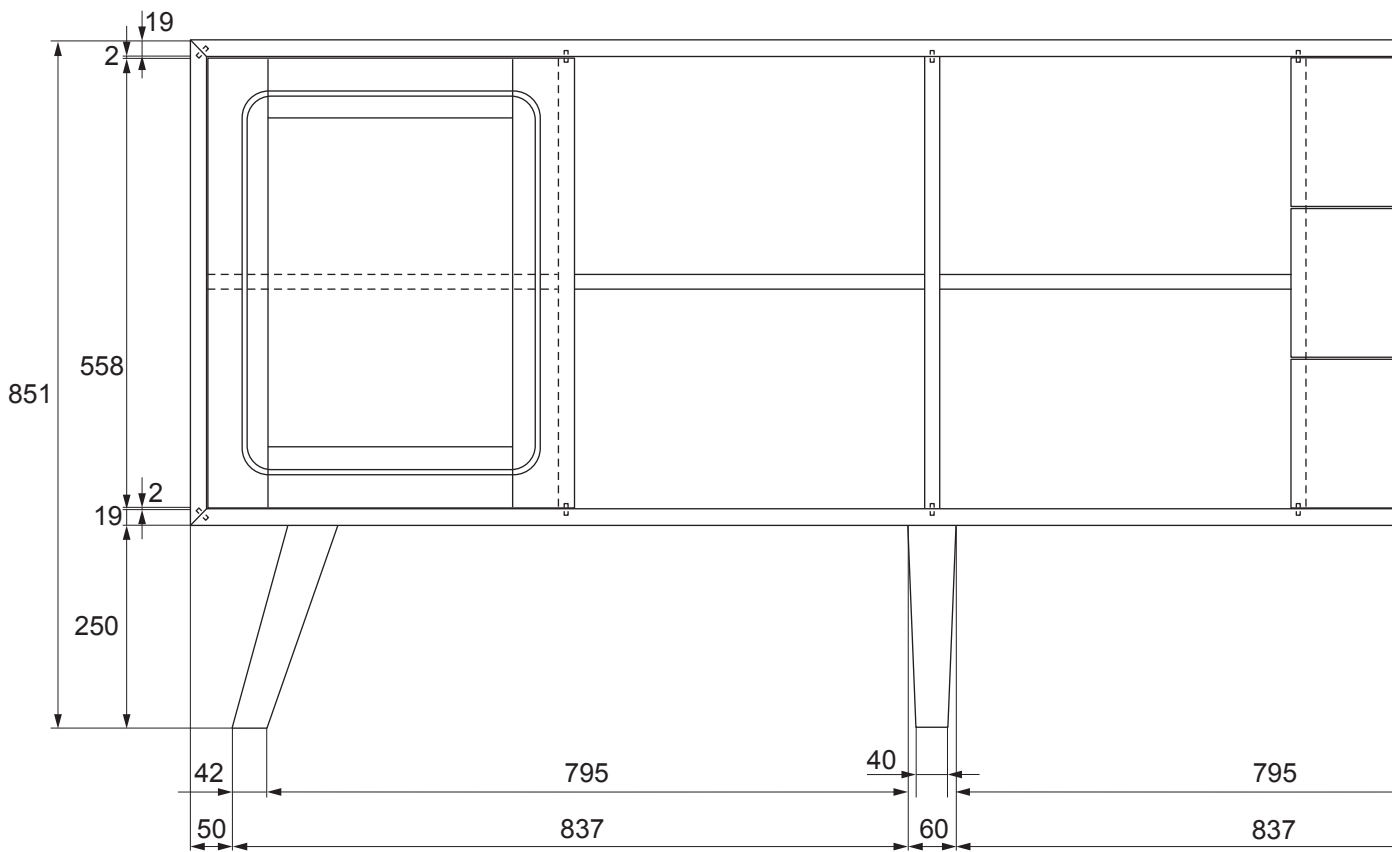

Credenza

Address Melbourne

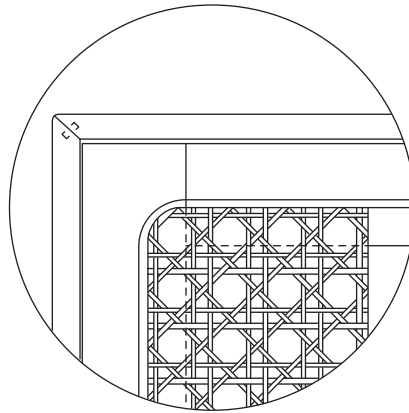
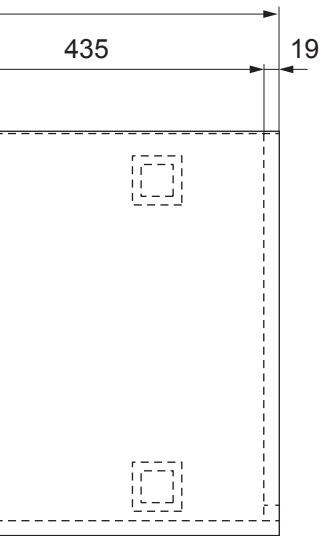

RATTAN DOOR

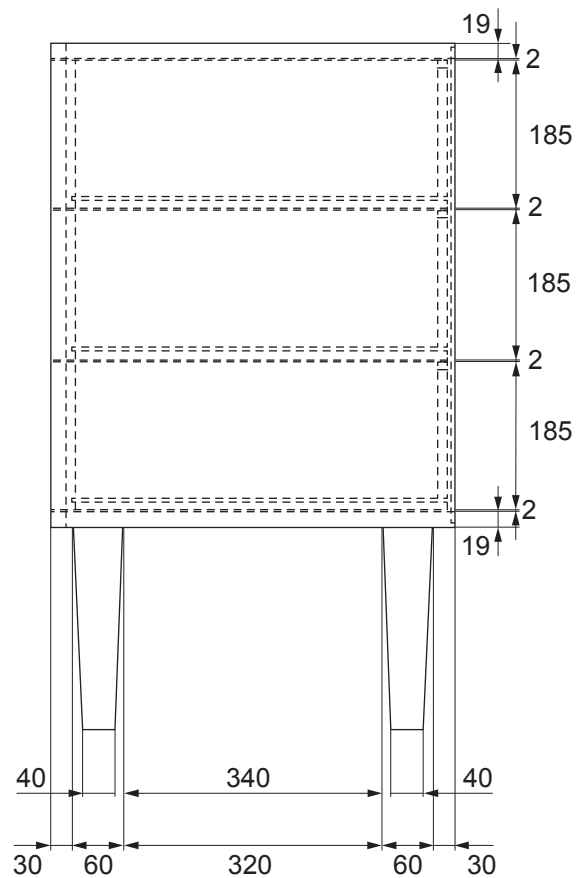
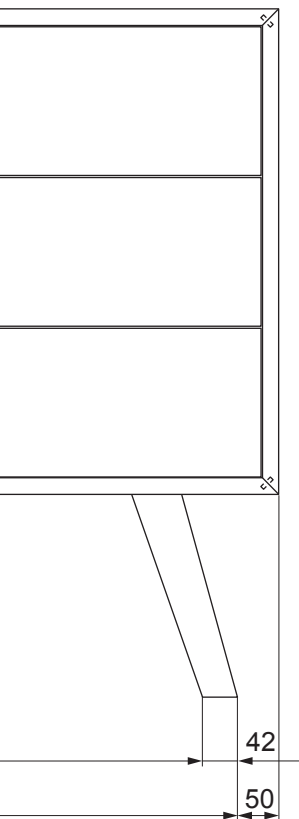

CLIENT S Cameron	PROJECT Credenza	DRAWING		
		DATE 01/02/25	No. INSERT	THIS DRAWING
		DRAWN BY	1	1
		DESIGNED	DRAWING REFERENCE	
		SCALE 1:12	1/1	

