



Victorian Certificate of Education

2012

SUPERVISOR TO ATTACH PROCESSING LABEL HERE

STUDENT NUMBER

Letter

Figures										
Words										

PHYSICS

Written examination 2

Wednesday 14 November 2012

Reading time: 11.45 am to 12.00 noon (15 minutes)

Writing time: 12.00 noon to 1.30 pm (1 hour 30 minutes)

QUESTION AND ANSWER BOOK

Structure of book

<i>Section</i>	<i>Number of questions</i>	<i>Number of questions to be answered</i>	<i>Number of marks</i>
A – Core – Areas of study			
1. Electric power	8	8	40
2. Interactions of light and matter	4	4	26
B – Detailed studies			
1. Synchrotron and its applications OR	12	12	24
2. Photonics OR	12	12	24
3. Sound	12	12	24
			Total 90

- Students are permitted to bring into the examination room: pens, pencils, highlighters, erasers, sharpeners, rulers, up to two pages (one A4 sheet) of pre-written notes (typed or handwritten) and one scientific calculator.
- Students are NOT permitted to bring into the examination room: blank sheets of paper and/or white out liquid/tape.

Materials supplied

- Question and answer book of 34 pages.
- A formula sheet.
- Answer sheet for multiple-choice questions.

Instructions

- Write your **student number** in the space provided above on this page.
- Check that your **name** and **student number** as printed on your answer sheet for multiple-choice questions are correct, **and** sign your name in the space provided to verify this.
- Unless otherwise indicated, the diagrams in this book are **not** drawn to scale.
- All written responses must be in English.

At the end of the examination

- Place the answer sheet for multiple-choice questions inside the front cover of this book.

Students are NOT permitted to bring mobile phones and/or any other unauthorised electronic devices into the examination room.

SECTION A – Core

Instructions for Section A

Answer **all** questions **for both** Areas of study in this section in the spaces provided. Write using black or blue pen.

Where an answer box has a unit printed in it, give your answer in that unit.

You should take the value of g to be 10 m s^{-2} .

In questions where more than one mark is available, appropriate working should be shown.

Areas of study	Page
Electric power	3
Interactions of light and matter	14

NO WRITING ALLOWED IN THIS AREA

Area of study 1 – Electric power

Question 1

Figure 1 shows a solenoid connected to a battery. At points P and Q, Earth has a horizontal magnetic field comparable in size to that produced by the solenoid at these points.

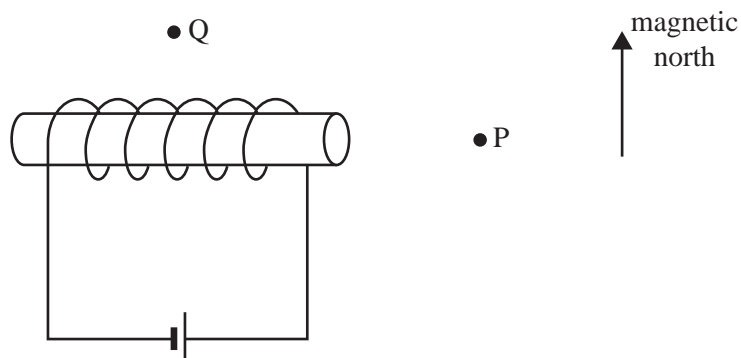

Figure 1

- a. Draw an arrow at point P to indicate the direction of the magnetic field at that point.

1 mark

- b. Roger has a small magnet that is free to rotate about an axis at its centre. This is shown in Figure 2. In this question, ignore the effect of Earth's magnetic field.



Figure 2

Roger places the magnet at point Q in Figure 1.

Identify which of the following best shows the orientation that the magnet will take. Write your answer in the box provided.

A.



B.



C.



D.



E.

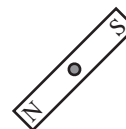

F.

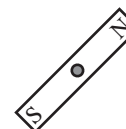

2 marks

Question 2

Figure 3 shows a small DC electric motor, powered by a battery through a split-ring commutator. The rectangular coil has sides KJ and LM of length 6.0 cm, and sides KL and JM of length 3.0 cm. The coil contains 50 turns of insulated wire.

The magnetic field between the poles of the magnet is uniform and of strength 0.050 T.

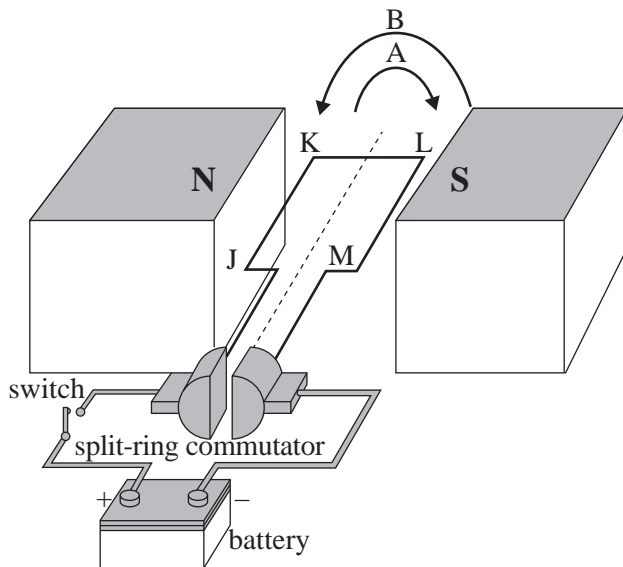

Figure 3

- a. The current is switched on when the coil is stationary in the position shown in Figure 3. Which of the following statements best describes the motion of the coil when the current is switched on? You may assume that any frictional forces opposing rotation are very low. Write your answer in the box provided.
- A. The coil will rotate in direction A shown in Figure 3.
 - B. The coil will rotate in direction B shown in Figure 3.
 - C. The coil will oscillate regularly between directions A and B.
 - D. The coil will remain stationary.

1 mark

- b. The current drawn from the battery is 2.0 A. Calculate the magnitude of the force on the side KJ of the motor when the coil is in the position shown in Figure 3.

2 marks

Question 3

Ferdi is deciding on an electricity supply for his caravan.

One option is an AC generator that provides a peak voltage of 150 V. With the AC supply, the total resistance of the appliances in the caravan is 6.0Ω .

Another option is a DC supply of 120 V. With the DC supply, the total resistance of the appliances in the caravan is 7.0Ω .

Use calculations to determine which of these options will provide the most power to the caravan.

2 marks

NO WRITING ALLOWED IN THIS AREA

Question 4

A farmer uses an AC motor to power an irrigation pump. The motor needs 900 V RMS AC input for the pump to operate correctly. When the motor is running with 900 V RMS AC, the motor draws 50 A RMS AC current.

- a. Calculate the power input to the motor when the pump is operating correctly. You may assume that the motor uses power just like a resistor. Give your answer in kilowatt.

kW

2 marks

To supply electricity to the AC motor that drives the pump, a water-driven AC generator is installed at a waterfall some distance away from the pump. The generator provides current at a voltage of 1000 V RMS AC.

The farmer uses two aluminium wires to link the generator to the pump, as shown in Figure 4. The wires have a total resistance of 7.0 Ω.

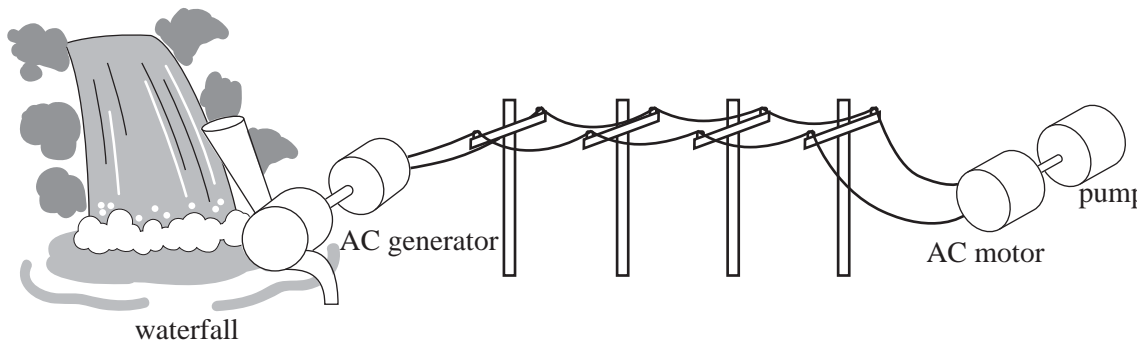

Figure 4

- b. The motor has a constant resistance of 18 Ω. Calculate the current flowing in the aluminium connecting wires.

A

2 marks

NO WRITING ALLOWED IN THIS AREA

- c. Determine whether the pump will operate correctly. Support your conclusion with calculations.

3 marks

- d. The farmer wishes to reduce the power losses in the electrical connections between the AC generator at the waterfall and the AC motor powering the irrigation pump. It is not possible to move the position of either the AC generator or the AC motor.

Identify and describe two different changes that would reduce the power losses between the AC generator and the AC motor. In your answer, you must also explain how each of the two changes you identified would reduce power losses.

first change _____

second change _____

4 marks

NO WRITING ALLOWED IN THIS AREA

Question 5

Students are using an AC generator with a coil that rotates at a steady speed in a uniform magnetic field. The generator is producing a sinusoidal voltage signal that varies with time, as shown in Figure 5.

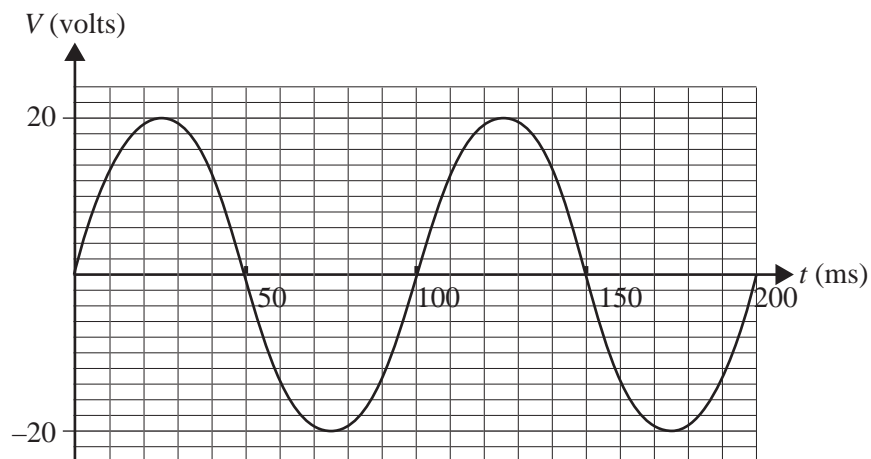
**Figure 5**

- a. Calculate the frequency of the AC signal shown in Figure 5.

Hz

2 marks

- b. Calculate the RMS voltage of the signal shown in Figure 5.

V

1 mark

- c. The students **halve** the speed of rotation of the generator. On the axes below, sketch the voltage signal that the AC generator will now produce. Label the voltage axis carefully with the correct numbers.

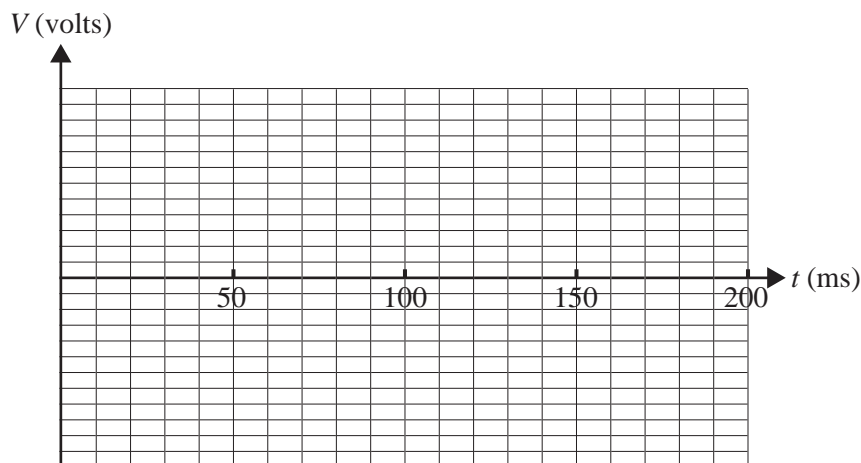

3 marks

Question 6

Students are testing a transformer. The transformer is working correctly. The transformer has 600 turns in the primary coil and 150 turns in the secondary coil.

- a. The students attach the primary coil to a 20 V RMS AC power supply. Calculate the RMS voltage across the secondary coil.

V

1 mark

- b. The students now connect the primary coil of the transformer to a 20 V battery and find, after a short time, that there is no voltage across the secondary coil.

Explain why there is no voltage produced across the secondary coil. In your explanation, include a reference to the relevant physics principle.

2 marks

Question 7

Students are experimenting with a simple AC generator, as shown in Figure 6. It consists of a rectangular coil of n turns that rotates at a constant speed in a uniform magnetic field.

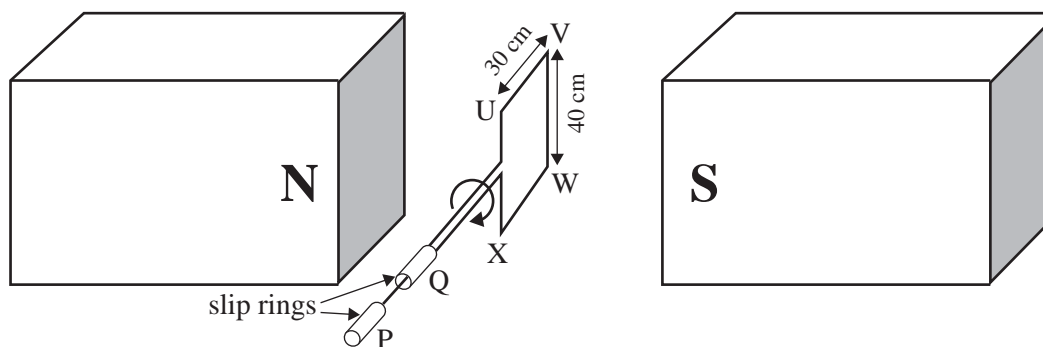
**Figure 6**

The uniform magnetic field in the region between the magnets is 0.030 T. The dimensions of the rectangular coil are 30 cm \times 40 cm.

The coil is located completely within the uniform magnetic field of the two magnets.

The coil is rotating at a steady rate of 2 rotations per second.

- a. Describe how the magnetic flux through the rotating coil changes as the coil makes a complete rotation. Take the starting point of the rotation to be the position shown in Figure 6. You do not need to include any calculations or numbers in your answer. You may use a sketch in your answer.

2 marks

- b. The generator produces a sinusoidal AC voltage. For a quarter rotation of the coil from the point shown in Figure 6, it generates an **average** emf of magnitude 3.6 V.

Calculate the number of turns in the rotating coil.

turns

3 marks

- c. The students replace the slip rings with a commutator. This changes the shape of the output voltage variation with time.

Describe the shape of the new output voltage of the generator compared with the shape of the original output voltage. You may use a sketch in your answer.

2 marks

Question 8

Figures 7a and 7b show a square loop being moved between the poles of a magnet. In the space between the poles there is a uniform magnetic field.

The loop moves at a steady speed from position 1 to position 3.

The loop is connected to a sensitive microammeter. The area of the loop is much less than the area of the magnetic field.

You may assume that the only magnetic field present is located directly between the north and south poles.

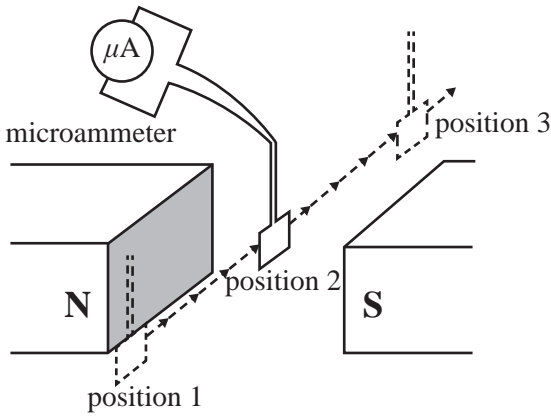

Figure 7a

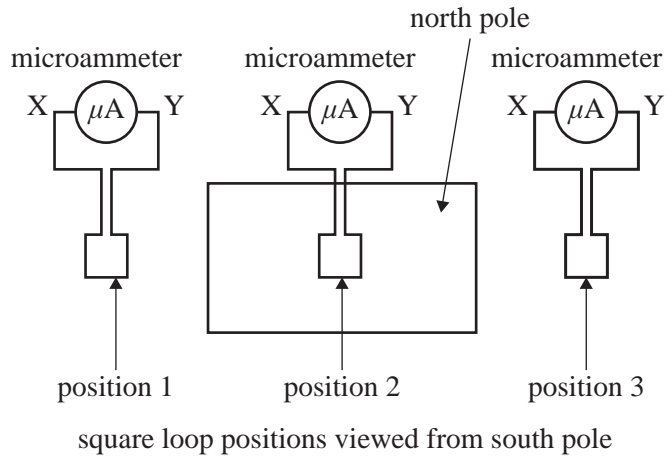
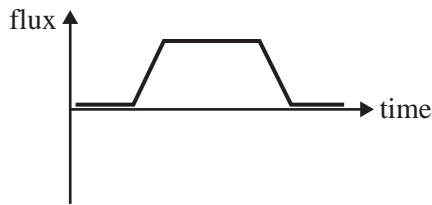

Figure 7b

- a. Which of the following graphs best shows how the flux through the square loop varies with time as it moves from position 1 through to position 3? Write your answer in the box provided.

A.



B.

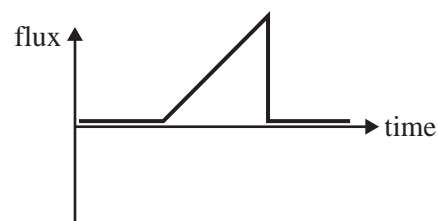

C.

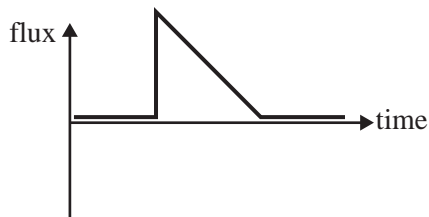

D.

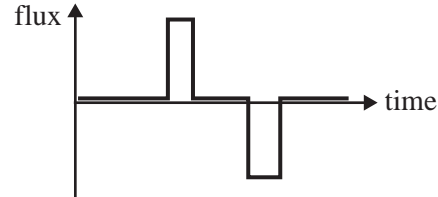

1 mark

NO WRITING ALLOWED IN THIS AREA

- b. Which of the following graphs best shows how the magnitude of the emf in the square loop varies with time as it moves from position 1 through to position 3? Write your answer in the box provided.

A.

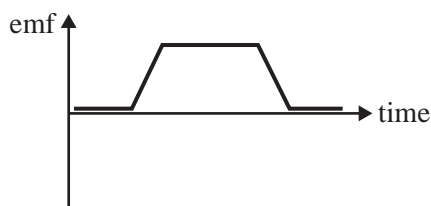

B.

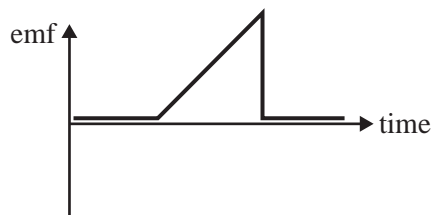

C.

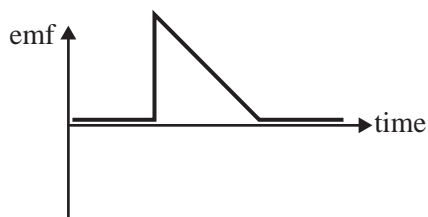

D.

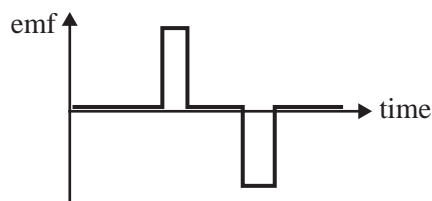

1 mark

- c. Describe the direction of the current in the square loop as it moves from position 2 to position 3, as viewed from the south pole (see Figure 7b). You may use a sketch in your answer. Explain the reasons for your answer.

3 marks

END OF AREA OF STUDY 1
SECTION A – continued
TURN OVER

NO WRITING ALLOWED IN THIS AREA

Area of study 2 – Interactions of light and matter

Question 1

Vishvi is carrying out photoelectric effect experiments. Her apparatus is shown in Figure 1.

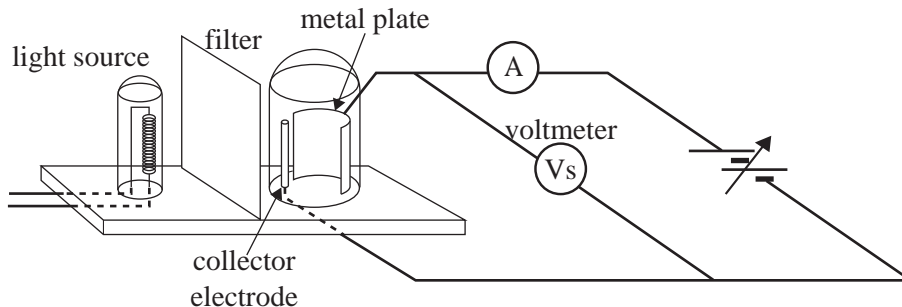

Figure 1

Vishvi uses two metal plates in the photoelectric cell. One plate is made of zinc and the other is made of aluminium. Vishvi uses light of a particular frequency to illuminate the zinc plate and then the aluminium plate, but finds that photoelectrons are emitted only by the zinc plate.

The threshold frequency of zinc for photoelectric emission is 7.40×10^{14} Hz and that of aluminium is 9.90×10^{14} Hz.

- a. Calculate the maximum wavelength (in nm) of the light required to emit electrons from the zinc plate.

nm

1 mark

- b. In an effort to eject photoelectrons from the aluminium plate, Vishvi increases the intensity of the light beam, but still finds that no photoelectrons are emitted.

Explain how this observation supports the particle model of light, but not the wave model of light.

3 marks

NO WRITING ALLOWED IN THIS AREA

In another photoelectric experiment, Vishvi uses light with a frequency of 7.50×10^{14} Hz to eject photoelectrons from a sodium surface. The work function of sodium is 2.28 eV.

- c. Calculate the maximum kinetic energy (in eV) of these photoelectrons.

eV

2 marks

- d. Calculate the **stopping voltage** that would be required to just prevent the most energetic electrons from reaching the collector electrode.

V

1 mark

Question 2

Two students set up a two-slit interference experiment with a source of laser light, as shown in Figure 2.

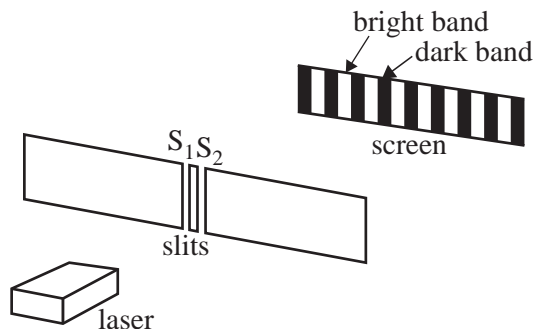

Figure 2
not to scale

The wavelength of the light from the laser is 612 nm. Figure 3 shows a sketch of the central section of the interference pattern that they obtain. The central band C, which is a bright band, is labelled.

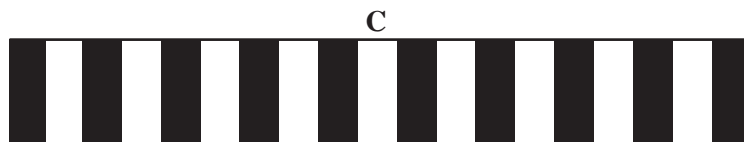

Figure 3

- a. The light energy output of the laser is $5.0 \times 10^{-3} \text{ J s}^{-1}$.
Calculate the number of photons leaving the laser every second. Write your answer in the box provided.

2 marks

- b. Explain why the central band of the pattern at point C is a bright band and not a dark band.

2 marks

- c. Another point on the pattern is further from slit S_1 than from slit S_2 by a distance of 2.142×10^{-6} m. Its position is to the **right** of point C in Figure 3, on page 16.

Indicate where this point is in Figure 3 by writing the letter X above the point. You must show your working.

3 marks

Another laser that produces light of a different wavelength is now used. The pattern is now spaced more closely. Figure 4a shows the new pattern and Figure 4b shows the original pattern.

The second bright band to the left of C in the **new** pattern is at the position labelled Y in Figure 4a. In the original pattern (Figure 4b), this was the position of the second **dark** band to the left of C.



Y C

new pattern
Figure 4a



Y C

original pattern
Figure 4b

- d. Calculate the wavelength of the light produced by this new laser.

nm

2 marks

Question 3

A beam of electrons is travelling at a constant speed of $1.5 \times 10^5 \text{ ms}^{-1}$. The beam shines on a crystal and produces a diffraction pattern. The pattern is shown in Figure 5. Take the mass of one electron to be $9.1 \times 10^{-31} \text{ kg}$.

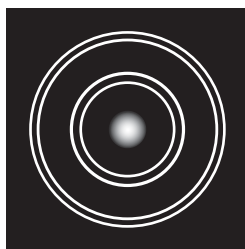

Figure 5

- a. Calculate the kinetic energy (in eV) of one of the electrons.

eV

2 marks

The beam of electrons is now removed and replaced by a beam of X-rays. The resulting pattern has the **same spacing** as that produced by the electron beam.

- b. Calculate the energy (in eV) of one X-ray photon.

eV

3 marks

NO WRITING ALLOWED IN THIS AREA

Question 4

Figure 6 shows the energy level diagram for the hydrogen atom.

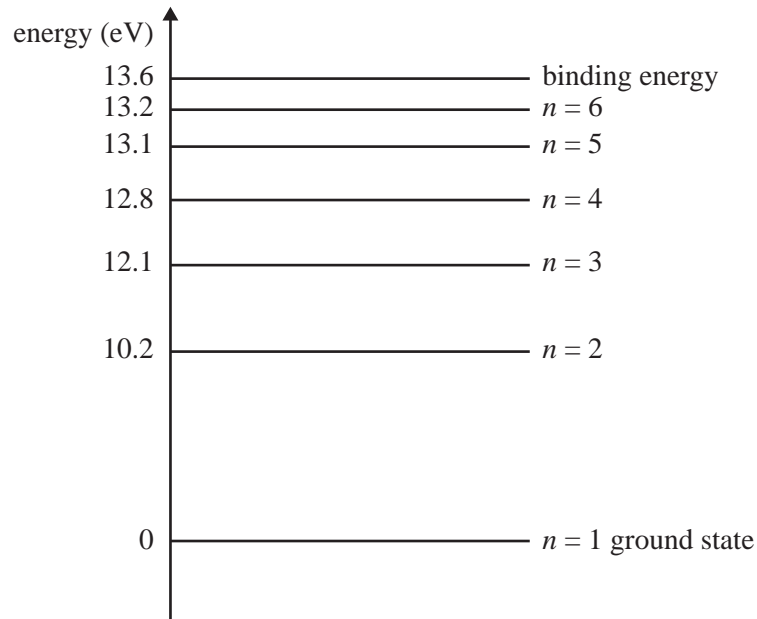
**Figure 6**

A particular hydrogen atom makes a transition from the $n = 2$ level to the $n = 4$ level by absorbing a photon.

- a. Calculate the wavelength of the photon involved.

nm

2 marks

The energy levels of the hydrogen atom are discrete (quantised) and there are no stable levels between them.

- b. In terms of the properties of the electron, explain why only certain energy levels are stable.

3 marks

**END OF SECTION A
TURN OVER**

NO WRITING ALLOWED IN THIS AREA

SECTION B – Detailed studies**Instructions for Section B**

Select **one** Detailed study.

Answer **all** questions from the Detailed study, **in pencil**, on the answer sheet provided for multiple-choice questions.

Write the name of your chosen Detailed study on the multiple-choice answer sheet **and** shade the matching box.

Choose the response that is **correct** or that **best answers** the question.

A correct answer scores 2, an incorrect answer scores 0.

Marks will **not** be deducted for incorrect answers.

No marks will be given if more than one answer is completed for any question.

You should take the value of g to be 10 m s^{-2} .

Detailed study	Page
Synchrotron and its applications	21
Photonics	25
Sound	29

NO WRITING ALLOWED IN THIS AREA

Detailed study 1 – Synchrotron and its applications

Question 1

Synchrotron radiation is generated because electrons

- A. change direction.
- B. collide with other electrons.
- C. collide with leftover air particles in the storage ring.
- D. have a speed very close to the speed of light.

Use the following information to answer Questions 2–5.

An electron gun is used to inject electrons into the linac of a synchrotron. Figure 1 shows a schematic diagram of the electron gun. The mass of an electron is 9.1×10^{-31} kg and the charge on an electron is 1.6×10^{-19} C.

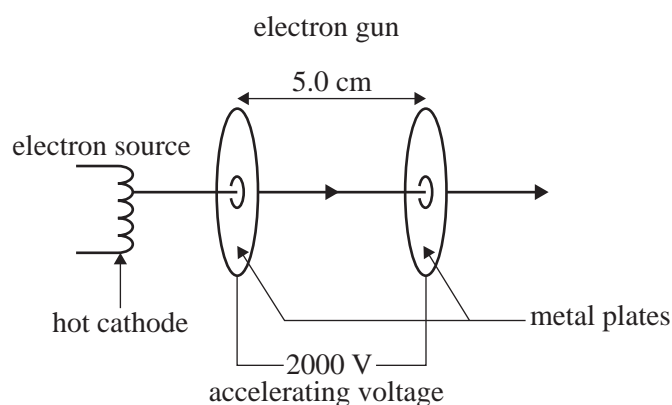

Figure 1

The electron is accelerated by an electric field generated by a voltage of 2000 V applied across the two plates. The plates are 5.0 cm apart.

Question 2

Which of the following is the best estimate of the magnitude of the electric force acting on an electron when it is between the plates?

- A. 1.6×10^{-17} N
- B. 6.4×10^{-17} N
- C. 6.4×10^{-15} N
- D. 4.0×10^4 N

Use the following additional information to answer Questions 3 and 4.

An electron leaves the electron gun travelling at $2.7 \times 10^7 \text{ m s}^{-1}$. The electron enters a uniform magnetic field and moves in a circular path of radius 14 cm, as shown in Figure 2.

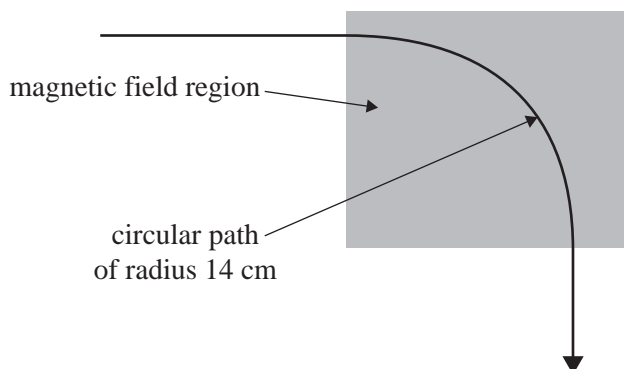

Figure 2

Question 3

Which of the following is the best estimate of the magnitude of the strength of the magnetic field?

- A. 1.1 mT
- B. 0.11 T
- C. 910 T
- D. 30 kT

Question 4

Which of the following best describes the direction of the magnetic field?

- A. down the page
- B. out of the page
- C. up the page
- D. into the page

Question 5

The accelerating voltage is now doubled to 4000 V.

Which of the following is the best estimate of the speed of an electron as it leaves the electron gun?

- A. $1.35 \times 10^7 \text{ m s}^{-1}$
- B. $2.7 \times 10^7 \text{ m s}^{-1}$
- C. $3.8 \times 10^7 \text{ m s}^{-1}$
- D. $5.4 \times 10^7 \text{ m s}^{-1}$

Use the following information to answer Questions 6 and 7.

Monochromatic X-rays are used to determine the structure of a crystal. Figure 3 shows the arrangement of the X-ray beam, the crystal and the detector. Figure 4 shows an enlarged version of the crystal planes. The planes are spaced a distance d apart.

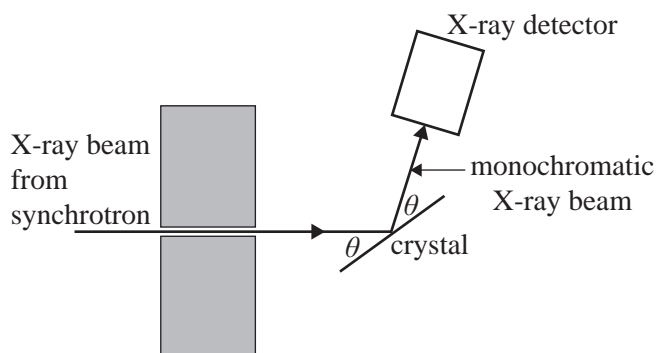

Figure 3

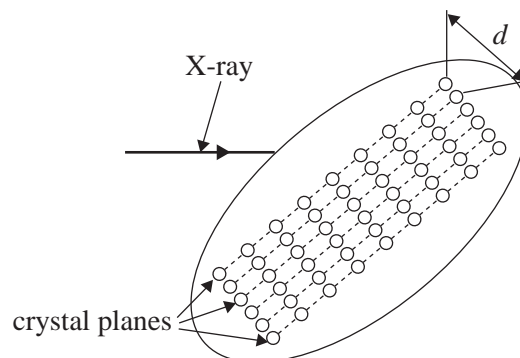

Figure 4

A narrow beam of X-rays with a single wavelength of 0.12 nm is incident on the crystal. In the experiment, the angle, θ , between the crystal and the detector is increased from zero while recording the number of detected X-rays. A sharp peak is observed at $\theta = 9.8^\circ$, as shown in Figure 5.

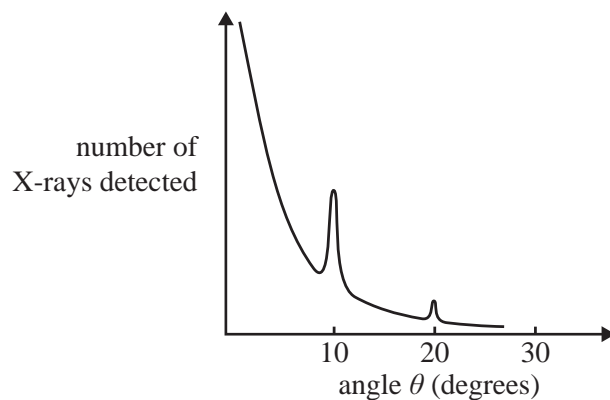

Figure 5

Question 6

Which of the following is the best estimate of the spacing, d , between the crystal planes?

- A. 0.061 nm
- B. 0.33 nm
- C. 0.35 nm
- D. 0.70 nm

Question 7

As the angle θ is increased further, a second peak is observed at $\theta = 20^\circ$, as shown in Figure 5.

Which of the following is the best explanation for the second peak?

- A. The peak is produced by X-rays of a longer wavelength.
- B. The peak is produced by X-rays of a shorter wavelength.
- C. The path difference producing constructive interference is equal to one and a half wavelengths.
- D. The path difference producing constructive interference is equal to two wavelengths.

Question 8

X-rays are produced by an X-ray tube and also by a synchrotron.

Compared with the X-rays produced by an X-ray tube, the X-rays from the synchrotron

- A. are less divergent.
- B. have a narrower spectrum.
- C. are composed of photons with greater energy.
- D. are composed of photons with longer wavelengths.

Question 9

Which of the following best describes what typically travels along a beamline in a synchrotron?

- A. X-rays only
- B. electrons travelling at close to the speed of light
- C. electromagnetic radiation with a range of wavelengths
- D. both X-rays and electrons travelling at close to the speed of light

Question 10

In the storage ring of a synchrotron, energy is lost by electrons in the form of synchrotron radiation.

Which of the following best describes the replacement of this loss of energy?

- A. The energy is replaced by undulators.
- B. The energy is replaced by sending electrons to the booster ring.
- C. The energy is replaced by a magnetic field in the circular sections of the ring.
- D. The energy is replaced by an electric field in the straight sections of the ring.

Question 11

A wiggler is an insertion device in the storage ring of a synchrotron.

Which of the following best describes the magnet (or magnets) of a wiggler?

- A. a row of magnets with the same polarity
- B. a row of magnets with alternating polarity
- C. an electromagnet driven by a high-frequency AC voltage
- D. an electromagnet driven by a high DC voltage that is switched on and off at a high frequency

Question 12

Which of the following best describes the purpose of a wiggler in a synchrotron?

- A. A wiggler replaces energy lost by synchrotron radiation.
- B. A wiggler ensures that electrons remain in the storage ring.
- C. A wiggler reduces the number of photons produced by the synchrotron.
- D. A wiggler increases the number of photons produced by the synchrotron.

NO WRITING ALLOWED IN THIS AREA

Detailed study 2 – Photonics**Question 1**

A semiconductor in a light-emitting diode (LED) has a band gap of 2.6 eV.

Which of the following is the best estimate of the wavelength of the light emitted from the LED when it is operating?

- A. 680 nm
- B. 580 nm
- C. 480 nm
- D. 410 nm

Question 2

Which of the following best describes the effect of changing the band gap on the light emitted by an LED?

- A. A larger band gap results in light of a lower frequency.
- B. Changing the band gap does not affect the wavelength or the frequency of the light.
- C. A smaller band gap results in light of a shorter wavelength.
- D. A larger band gap results in light of a higher frequency.

Question 3

Which of the following best describes how light is produced in an LED?

- A. Photons are emitted when valence band electrons lose energy.
- B. Photons are emitted when conduction band electrons lose energy.
- C. Photons are emitted when valence band electrons move to the conduction band.
- D. Photons are emitted when the band gap changes, allowing electron transitions.

Question 4

Many applications of photonics require a **coherent** source of light, such as a laser.

Coherent light is best described as

- A. light with fixed phase relationships in the beam.
- B. light with a very narrow range of wavelengths.
- C. light with a very narrow focused beam.
- D. light with a very high-intensity beam.

Use the following information to answer Questions 5 and 6.

A stepped-index optical fibre is shown in Figure 1. The refractive index of the core has a value of 1.62.

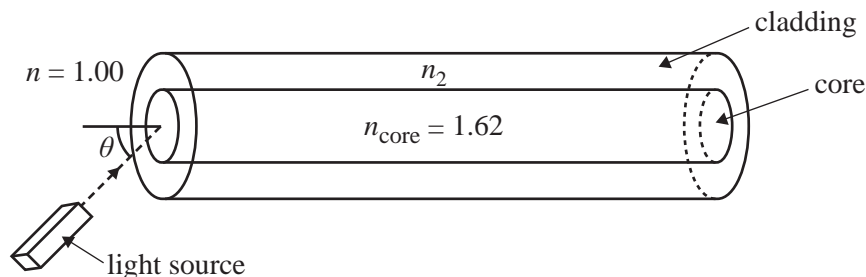

Figure 1
not to scale

Question 5

The critical angle between the core and the cladding is 70° .

Which of the following is closest to the value of n_2 , the refractive index of the cladding?

- A. 0.55
- B. 1.00
- C. 1.52
- D. 1.82

Question 6

The maximum value of θ that ensures that the beam from the light source is totally internally reflected within the fibre is called the acceptance angle.

Which of the following is closest to the acceptance angle of this optical fibre?

- A. 20°
- B. 34°
- C. 50°
- D. 70°

Question 7

Designers of another optical fibre are considering various combinations of refractive indices for the core and cladding. The table below shows the refractive indices for the four materials that they are considering.

Which of the four materials would produce a fibre with the **smallest** acceptance angle?

Material	n_{core}	n_{cladding}
A.	1.22	1.25
B.	1.42	1.40
C.	1.59	1.61
D.	1.78	1.65

NO WRITING ALLOWED IN THIS AREA

Question 8

Students are testing light transmission in a long single-mode optical fibre. In one of the tests, they compare the transmission of infrared light pulses ($\lambda = 1100 \text{ nm}$) with the transmission of green light pulses ($\lambda = 600 \text{ nm}$).

The refractive index of the core of the optical fibre is greater for green light than it is for infrared light. Both of these pulses reach the end of the optical fibre.

Which of the following statements is correct?

- A. The infrared pulse takes the same time as the green pulse to reach the other end of the optical fibre.
- B. The infrared pulse takes a longer time than the green pulse to reach the other end of the optical fibre.
- C. The infrared pulse takes a shorter time than the green pulse to reach the other end of the optical fibre.
- D. It is not possible to determine the relative travel times of the two pulses without further information about attenuation within the optical fibre.

Question 9

Students are interested in the attenuation of different wavelengths in optical fibres. Data on Rayleigh scattering and absorption for a particular optical fibre are shown in Figure 2.

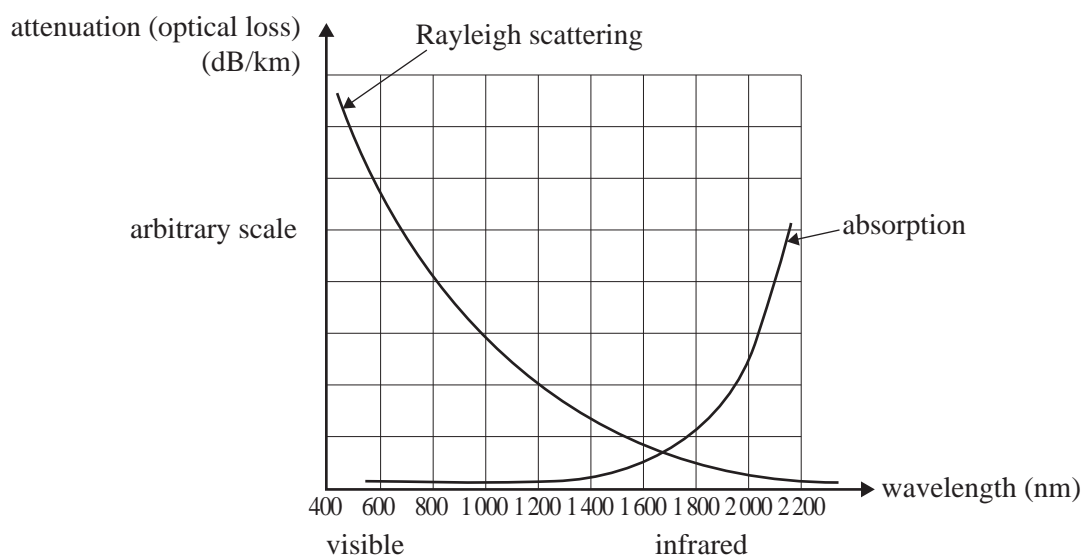

Figure 2

Using this graph, the students conclude that light of wavelength 800 nm will be attenuated more than light of wavelength 1800 nm.

Which of the following provides the best explanation for this conclusion?

- A. Rayleigh scattering at 1800 nm is greater than attenuation at 800 nm.
- B. Only absorption is responsible for attenuation.
- C. Only Rayleigh scattering is responsible for attenuation.
- D. Rayleigh scattering at 800 nm is greater than attenuation at 1800 nm.

Question 10

One factor that limits the speed of data transmission in step-index optical fibres is **modal dispersion**.

Which of the following statements best describes modal dispersion?

- A. Modal dispersion occurs when the speed of light of various modes is different.
- B. Modal dispersion occurs when light follows different paths along the optical fibre.
- C. Modal dispersion is the combined result of scattering and absorption in optical fibres.
- D. Modal dispersion occurs when light leaks from the core into the cladding, due to insufficient total internal reflection.

Question 11

An endoscope is a device for imaging internal organs of the body. In an endoscope, flexible optical fibres are surrounded by light sources, as shown in Figure 3.

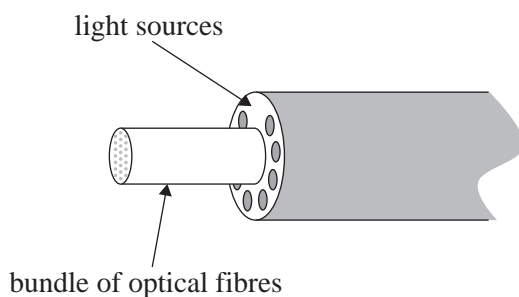

Figure 3

Which of the following statements best explains how the bundle of fibres operates to form an image?

- A. The bundle contains many fibres, each of which contributes one part of the image.
- B. The bundle contains many fibres in order to gather sufficient light.
- C. The light sources trap light by total internal reflection.
- D. The bundle acts as an image-forming lens.

Question 12

In long-distance transmissions with optical fibres, it is important to minimise dispersion.

Which of the following would best achieve this?

- A. use of a multimode fibre with an LED as the light source
- B. use of a multimode fibre with a wide-spectrum light source
- C. use of a single-mode fibre with an LED as the light source
- D. use of a single-mode fibre with a laser diode as the light source

Detailed study 3 – Sound

Use the following information to answer Questions 1–4.

A loudspeaker on a school oval is emitting a constant volume sound equally in all directions. The frequency of the sound is 100 Hz. Take the speed of sound to be 340 m s^{-1} .

Question 1

Which of the following is the best estimate of the wavelength of the sound?

- A. 1.7 m
- B. 3.4 m
- C. 100 m
- D. 340 m

Question 2

Alex stands at X, a point 20 m from the loudspeaker.

Which of the following statements is correct?

- A. The loudness of the sound that Alex hears at X is increasing and decreasing 100 times per second.
- B. Every 0.01 seconds, the loudness of the sound that Alex hears rises and falls.
- C. The loudness of the sound waves reaching Alex is constant.
- D. Particles of air are moving past Alex at 340 m s^{-1} .

Question 3

The sound intensity level of the sound from the loudspeaker at point X is 63 dB.

Which of the following is closest to the sound intensity at point X?

- A. $1.0 \times 10^{-57} \text{ W m}^{-2}$
- B. $2.0 \times 10^{-5} \text{ W m}^{-2}$
- C. $2.0 \times 10^{-6} \text{ W m}^{-2}$
- D. $2.0 \times 10^{-7} \text{ W m}^{-2}$

Question 4

Alex moves to a new point that is 10 m from the loudspeaker.

Which of the following is closest to the sound intensity level at this new point?

- A. 69 dB
- B. 66 dB
- C. 60 dB
- D. 57 dB

Use the following information to answer Questions 5–7.

The graph in Figure 1 shows the relationship between sound intensity level (dB), frequency (Hz) and loudness (phon) as perceived by Xena.

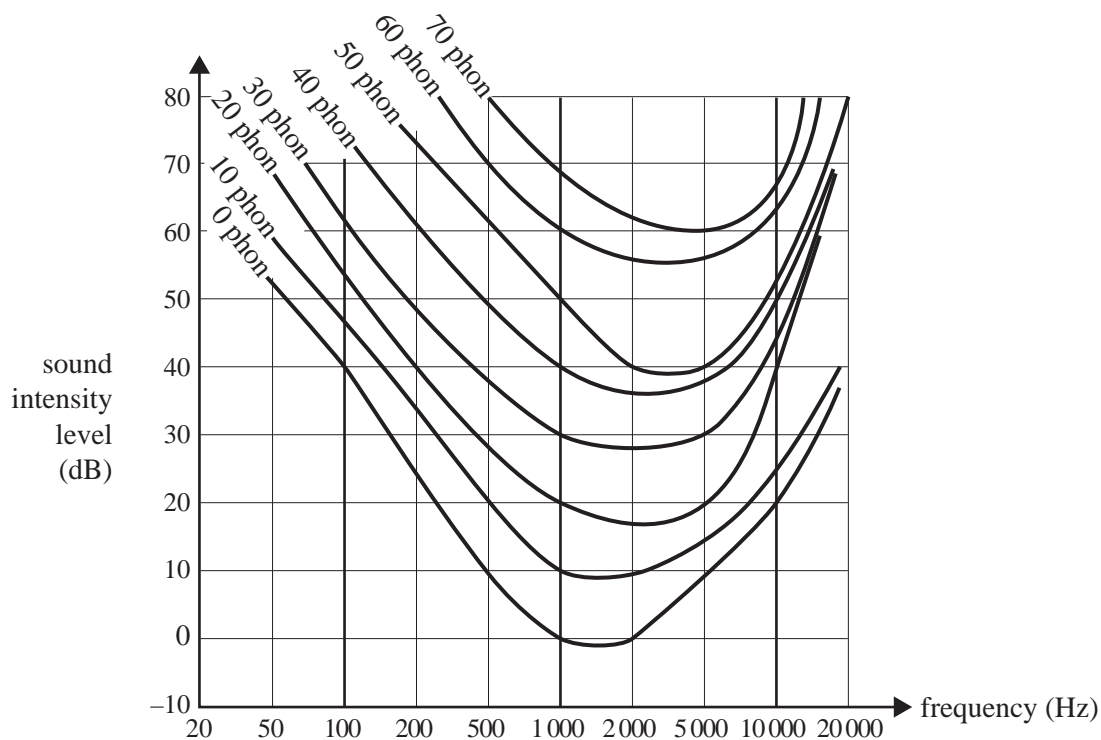

Figure 1

Question 5

With the frequency of the sound at 5000 Hz, the loudspeaker's volume is adjusted so that the sound intensity level that reaches Xena is 40 dB.

Which of the following is the best estimate of the loudness with which Xena hears the sound?

- A. 20 phon
- B. 30 phon
- C. 40 phon
- D. 50 phon

NO WRITING ALLOWED IN THIS AREA

Use the following additional information to answer Questions 6 and 7.

A distant fire siren emits two frequencies that alternate every second. The two frequencies are 1000 Hz and 3000 Hz. At the point where Xena is standing, both frequency sounds have a sound intensity level of 40 dB.

Question 6

Which of the following best describes Xena's perception of the loudness of the two frequencies of the siren?

- A. The 1000 Hz frequency will not be heard but the 3000 Hz frequency will be heard.
- B. The 1000 Hz frequency will have a greater loudness than the 3000 Hz frequency.
- C. The 3000 Hz frequency will have a greater loudness than the 1000 Hz frequency.
- D. Both frequencies will have the same loudness.

Question 7

A microphone is used to pick up the sound of the siren to record it. The frequency response curve for the microphone is shown in Figure 2.

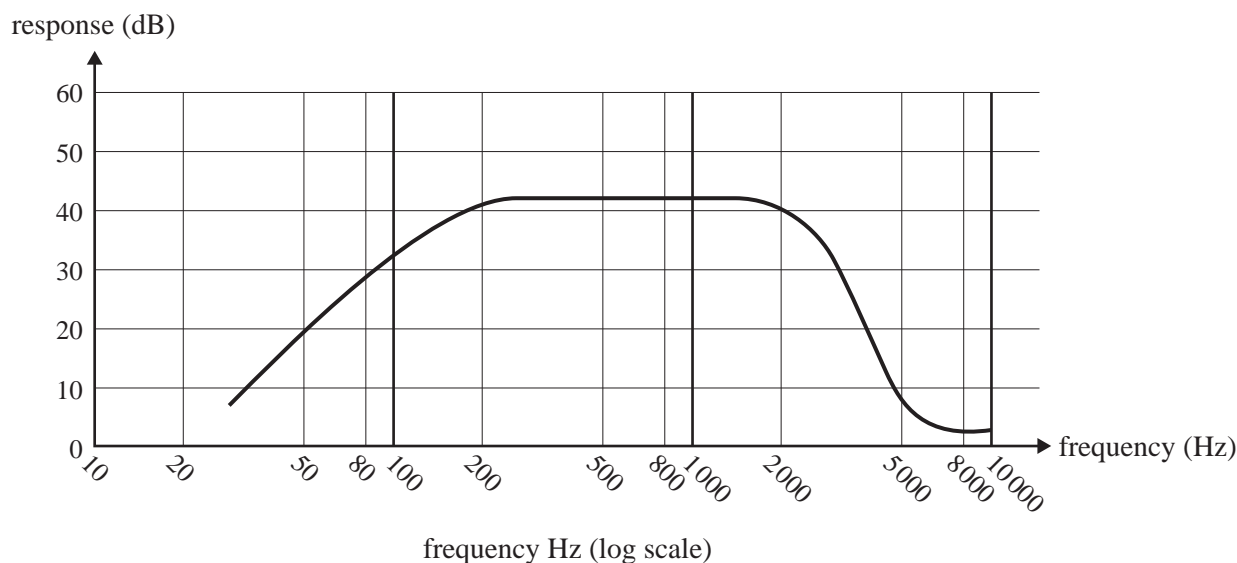

Figure 2

With the 1000 Hz and 3000 Hz sounds at equal sound intensity levels, which of the following is correct?

- A. The microphone output will be the same for both sounds.
- B. The output will depend on the speed of sound at the microphone.
- C. The microphone output for the 1000 Hz sound will be less than for the 3000 Hz sound.
- D. The microphone output for the 3000 Hz sound will be less than for the 1000 Hz sound.

Question 8

Another siren emits sounds of 500 Hz and 5000 Hz that alternate every second. The two frequencies have the same sound intensity level when Xena is standing 10 m from the siren, as shown in Figure 3.

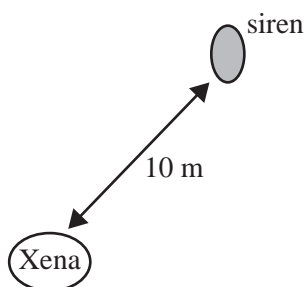
**Figure 3**

The siren is now placed on one side of a high wall with a narrow opening in it. Xena is standing on the other side of the wall. She is still 10 m from the siren. The situation is shown in Figure 4.

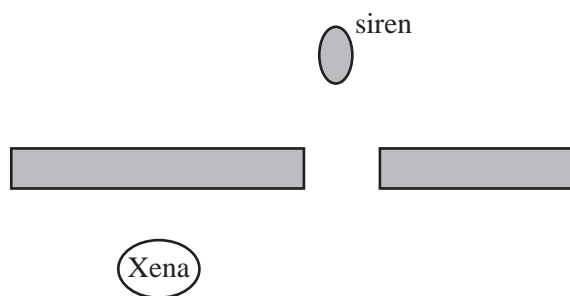
**Figure 4**

Xena finds that both frequencies are softer than they were before the siren was placed on the other side of the wall. However, one of the frequencies is relatively much softer than the other frequency.

Which of the following statements is correct?

- A. The 5000 Hz sound will be relatively softer because of diffraction effects.
- B. The 500 Hz sound will be relatively softer because of diffraction effects.
- C. The 5000 Hz sound will be relatively softer because some of the higher-frequency sound will reflect off the front of the wall more than the lower-frequency sound.
- D. The 500 Hz sound will be relatively softer because some of the lower-frequency sound will reflect off the front of the wall more than the higher-frequency sound.

Use the following information to answer Questions 9 and 10.

Freda and Fred are studying sound resonance. They have a tube with a sliding inner tube so that the combined length of the tubes can be adjusted. A cap can be placed across one end to form a closed end.

They have an audio oscillator, a loudspeaker and a frequency meter.

Figure 5 shows the situation. The speed of sound in air should be taken to be 340 m s^{-1} . The oscillator is set to a frequency of 170 Hz.

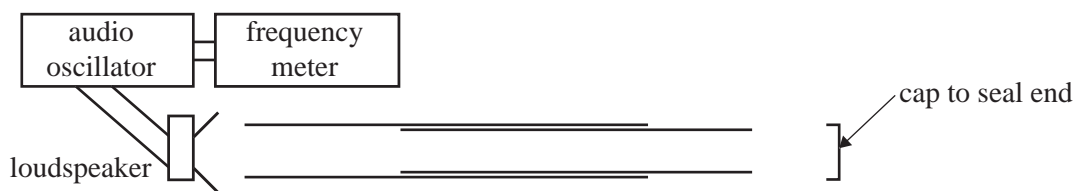

Figure 5

With the cap **on**, Freda and Fred move the sliding section of the tube until they reach the fundamental (lowest-frequency) resonance.

Question 9

Which of the following is closest to the combined length of the tubes when the fundamental frequency resonance is reached?

- A. 0.25 m
- B. 0.50 m
- C. 1.0 m
- D. 2.0 m

Question 10

Freda and Fred now increase the combined length of the tubes by sliding out the inner tube until they can hear the next resonance.

Which of the following is closest to the combined length of the tubes when this next resonance is reached?

- A. 0.75 m
- B. 1.0 m
- C. 1.5 m
- D. 3.0 m

Question 11

A baffle is fitted to a loudspeaker to improve its sound quality.

Which of the following best describes the physical principle that a baffle uses to improve the sound quality of a loudspeaker?

- A. A baffle reduces destructive interference between sound from the front and back of the loudspeaker.
- B. A baffle increases destructive interference between sound from the front and back of the loudspeaker.
- C. A baffle reduces diffraction from the front of the loudspeaker.
- D. A baffle increases diffraction from the front of the loudspeaker.

Question 12

Microphones convert pressure variations due to sound waves into AC voltage signals.

Which of the following microphone types have voltage signal outputs that can be calculated using Faraday's law of electromagnetic induction?

- A. electret-condenser and crystal microphones
- B. electret-condenser microphones only
- C. dynamic and velocity microphones
- D. velocity microphones only

NO WRITING ALLOWED IN THIS AREA



**Victorian Certificate of Education
2012**

PHYSICS
Written examination 2

Wednesday 14 November 2012

Reading time: 11.45 am to 12.00 noon (15 minutes)

Writing time: 12.00 noon to 1.30 pm (1 hour 30 minutes)

FORMULA SHEET

Directions to students

- A question and answer book is provided with this formula sheet.

Students are NOT permitted to bring mobile phones and/or any other unauthorised electronic devices into the examination room.

1	photoelectric effect	$E_{K\max} = hf - W$
2	photon energy	$E = hf$
3	photon momentum	$p = \frac{h}{\lambda}$
4	de Broglie wavelength	$\lambda = \frac{h}{p}$
5	resistors in series	$R_T = R_1 + R_2$
6	resistors in parallel	$\frac{1}{R_T} = \frac{1}{R_1} + \frac{1}{R_2}$
7	magnetic force	$F = I l B$
8	electromagnetic induction	emf : $\varepsilon = -N \frac{\Delta\Phi}{\Delta t}$ flux: $\Phi = BA$
9	transformer action	$\frac{V_1}{V_2} = \frac{N_1}{N_2}$
10	AC voltage and current	$V_{\text{RMS}} = \frac{1}{\sqrt{2}} V_{\text{peak}}$ $I_{\text{RMS}} = \frac{1}{\sqrt{2}} I_{\text{peak}}$
11	voltage; power	$V = RI$ $P = VI$
12	transmission losses	$V_{\text{drop}} = I_{\text{line}} R_{\text{line}}$ $P_{\text{loss}} = I_{\text{line}}^2 R_{\text{line}}$
13	mass of the electron	$m_e = 9.1 \times 10^{-31} \text{ kg}$
14	charge on the electron	$e = -1.6 \times 10^{-19} \text{ C}$
15	Planck's constant	$h = 6.63 \times 10^{-34} \text{ J s}$ $h = 4.14 \times 10^{-15} \text{ eV s}$
16	speed of light	$c = 3.0 \times 10^8 \text{ m s}^{-1}$
17	Acceleration due to gravity at Earth's surface	$g = 10 \text{ m s}^{-2}$

Detailed study 1 – Synchrotron and its applications

18	energy transformations for electrons in an electron gun (<100 keV)	$\frac{1}{2} m v^2 = eV$
19	radius of electron beam	$r = mv/eB$
20	force on an electron	$F = evB$
21	Bragg's law	$n\lambda = 2d\sin\theta$
22	electric field between charged plates	$E = \frac{V}{d}$

Detailed study 2 – Photonics

23	band gap energy	$E = \frac{hc}{\lambda}$
24	Snell's law	$n_1 \sin \theta_1 = n_2 \sin \theta_2$

Detailed study 3 – Sound

25	speed, frequency and wavelength	$v = f\lambda$
26	intensity and levels	<p>sound intensity level (in dB) = $10 \log_{10} \left(\frac{I}{I_0} \right)$ where $I_0 = 1.0 \times 10^{-12} \text{ W m}^{-2}$</p>

Prefixes/Units

p = pico = 10^{-12}

n = nano = 10^{-9}

μ = micro = 10^{-6}

m = milli = 10^{-3}

k = kilo = 10^3

M = mega = 10^6

G = giga = 10^9

t = tonne = 10^3 kg

END OF FORMULA SHEET