

STUDENT NUMBER Letter

VCE VET ENGINEERING STUDIES

Written examination

Tuesday 15 November 2016

Reading time: 9.00 am to 9.15 am (15 minutes)

Writing time: 9.15 am to 10.45 am (1 hour 30 minutes)

QUESTION AND ANSWER BOOK

Structure of book

| <i>Section</i> | <i>Number of questions</i> | <i>Number of questions to be answered</i> | <i>Number of marks</i> |
|----------------|----------------------------|---|------------------------|
| A | 20 | 20 | 20 |
| B | 18 | 18 | 80 |
| | | | Total 100 |

- Students are permitted to bring into the examination room: pens, pencils, highlighters, erasers, sharpeners, rulers, one scientific calculator, a protractor, a set square and aids for curve sketching.
- Students are NOT permitted to bring into the examination room: blank sheets of paper and/or correction fluid/tape.

Materials supplied

- Question and answer book of 27 pages.
- Answer sheet for multiple-choice questions.

Instructions

- Write your **student number** in the space provided above on this page.
- Check that your **name** and **student number** as printed on your answer sheet for multiple-choice questions are correct, **and** sign your name in the space provided to verify this.
- Unless otherwise indicated, the diagrams in this book are **not** drawn to scale.
- All written responses must be in English.

At the end of the examination

- Place the answer sheet for multiple-choice questions inside the front cover of this book.

Students are NOT permitted to bring mobile phones and/or any other unauthorised electronic devices into the examination room.

SECTION A – Multiple-choice questions

Instructions for Section A

Answer **all** questions in pencil on the answer sheet provided for multiple-choice questions.

Choose the response that is **correct** or that **best answers** the question.

A correct answer scores 1; an incorrect answer scores 0.

Marks will **not** be deducted for incorrect answers.

No marks will be given if more than one answer is completed for any question.

Unless otherwise indicated, the diagrams in this book are **not** drawn to scale.

Question 1

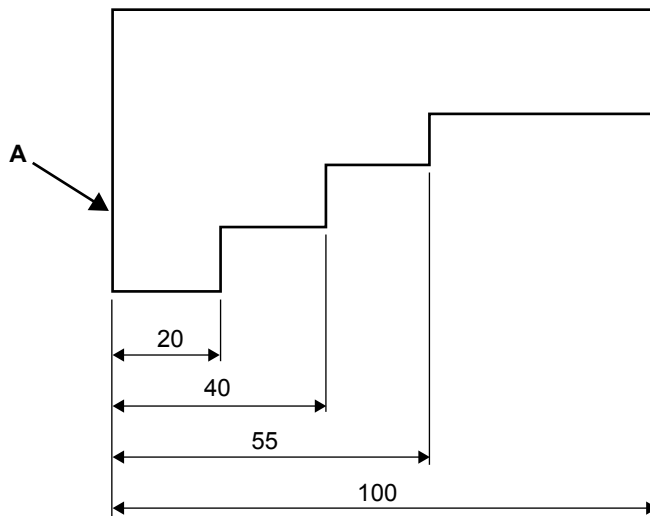

In the drawing shown above, the edge labelled ‘A’ is called a

- A. zero edge.
- B. datum edge.
- C. starting edge.
- D. dimension edge.

Question 2

Which one of the following is an example of the correct way to draw an external thread on an engineering drawing?

- A.
- B.
- C.
- D.

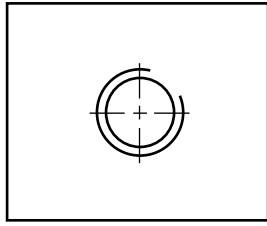
Question 3

The drawing above shows a metal plate with a

- A. countersunk hole.
- B. threaded hole.
- C. reamed hole.
- D. bored hole.

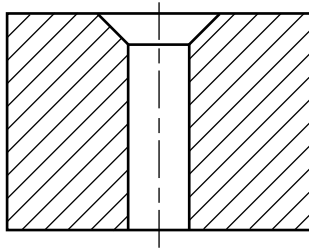
Question 4

The sectional drawing above shows a

- A. counterbored hole.
- B. countersunk hole.
- C. threaded hole.
- D. reamed hole.

Question 5

When implementing the 5S system, arranging required tools so they are easy to find and to put away is part of which step?

- A. Set in order
- B. Standardise
- C. Shine
- D. Sort

Question 6

While operating a machine, a worker notices that a safety guard is faulty and not closing correctly.

What is the worker's responsibility as an employee?

- A. Keep operating the machine until the supervisor arrives.
- B. Make their own temporary repairs and keep operating the machine.
- C. Stop operating the machine and report the faulty safety guard immediately.
- D. Keep operating the machine if the worker thinks the safety guard is only a minor fault.

Question 7

An organisation occasionally disposes of small amounts of waste oil.

What is the recommended way to dispose of waste oil?

- A. Use the waste oil in the garden as a weedkiller.
- B. Place the waste oil in a sealed container and dispose of it in a rubbish bin.
- C. Mix the waste oil with an equal amount of degreaser and pour it down the drain.
- D. Place the waste oil in a drum for collection by a waste disposal company.

Question 8

Source: creatOR76/Shutterstock.com

The mechanical handling equipment shown above is most suited to shifting

- A. pallets.
- B. engines.
- C. small bags.
- D. small boxes.

Question 9

Pieces of pipe that are 70 mm long are being cut with a saw that has a 3 mm thick blade.

How many 70 mm long pieces of pipe can be cut from a 6 m length, using a 3 mm thick blade?

- A. 74
- B. 82
- C. 85
- D. 88

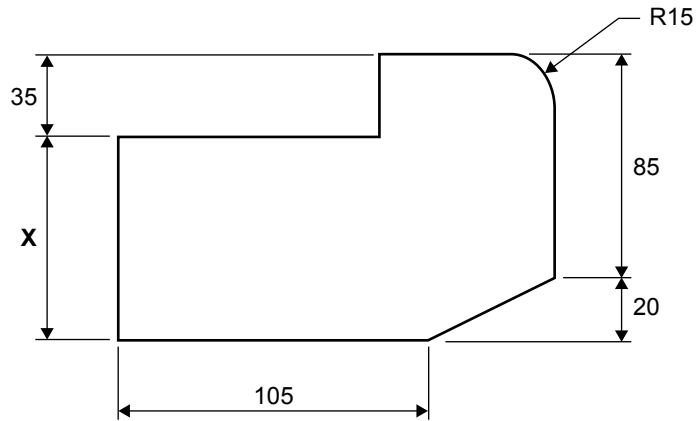
Question 10

What is the length of side 'X' in the drawing shown above?

- A. 50
- B. 55
- C. 70
- D. 85

Question 11

Which one of the following safety signs would be displayed where drums of petrol are stored?

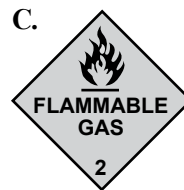

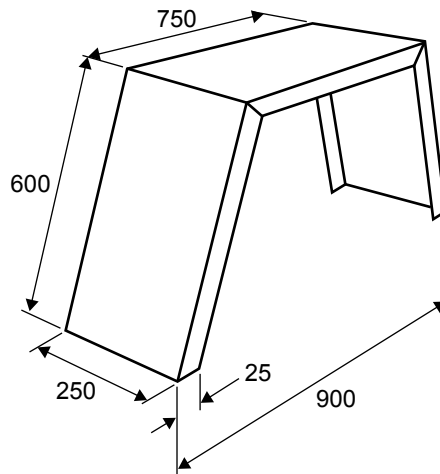
Question 12

The mudguard shown above will be bent from a single piece of material.
What is the width of the material needed?

- A. 250
- B. 275
- C. 300
- D. 325

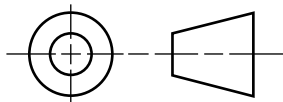
Question 13

The symbol shown above indicates that an engineering drawing has been drawn in

- A. 3D view.
- B. isometric view.
- C. first-angle projection.
- D. third-angle projection.

Question 14

When machines and equipment are being repaired, they should be 'locked and tagged'.
Who is authorised to remove the lock and tag?

- A. anyone from maintenance
- B. only supervisors or managers
- C. the operator of the machine or equipment
- D. only the person who locked and tagged the machine or equipment

Question 15

An MSDS is **most** likely to contain

- A. instructions for performing a team lift.
- B. instructions on how to safely charge a forklift.
- C. procedures to follow in case of a chemical spill.
- D. drawings for the correct placement of safety guards on machinery.

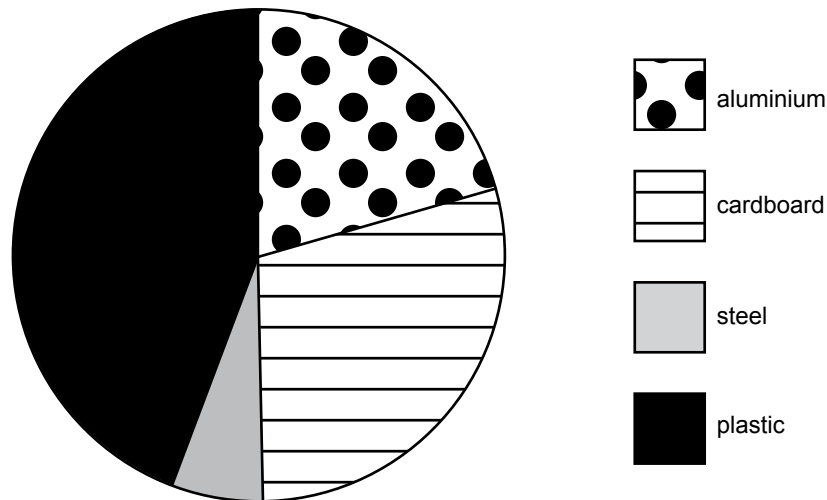
Question 16

The pie chart above shows the breakdown of materials recycled by a manufacturing company.

According to the pie chart, the two materials that are recycled the most are

- A. aluminium and plastic.
- B. cardboard and plastic.
- C. aluminium and steel.
- D. cardboard and steel.

Question 17

The main advantage of light-emitting diode (LED) lighting is that LED lights

- A. are cheap to buy.
- B. are easy to install.
- C. look better than globes.
- D. require less power.

Question 18

Which step of the 5S system does a 5S audit belong to?

- A. Sort
- B. Shine
- C. Sustain
- D. Set in order

Question 19

There is excess rubbish in a factory, including broken pallets, plastic wrapping and cardboard boxes. The owner of the factory considers burning this rubbish to save money on disposal costs.

What external factor would be the main consideration that would stop the owner from burning the rubbish?

- A. the police
- B. the fire brigade
- C. the factory next door
- D. government legislation

Question 20

Using an air conditioner to cool a workshop in summer consumes a lot of power.

What would be the **best** option to reduce the power consumed by running an air conditioner regularly in a workshop?

- A. Open all external doors.
- B. Install double-glazed windows.
- C. Change the angle of the air-conditioner vents.
- D. Lower the thermostat control from 20 °C to 18 °C.

CONTINUES OVER PAGE

TURN OVER

SECTION B

Instructions for Section B

Answer **all** questions in the spaces provided.
 All dimensions are in millimetres (mm) except where specified.
 Unless otherwise indicated, the diagrams in this book are **not** drawn to scale.

Question 1 (3 marks)

For each of the items listed in the table below, name a mechanical device or aid that would be suitable for shifting the item safely.

| Item | Mechanical device or aid |
|--|--------------------------|
| oxygen cylinder (from room to room) | |
| 20 × 5 kg bags of bolts (from truck to storeroom) | |
| heavy vice (to be lifted onto milling machine table) | |

Question 2 (3 marks)

A large engineering company is considering ways to reduce power usage. The company currently uses electricity to power:

- 35 large machines
- lighting for the factory
- lighting for offices (some office areas are not always occupied)
- external lighting (night only).

With reference to the list above, suggest three practical ways that the company could reduce its power usage.

1. _____

2. _____

3. _____

Question 3 (2 marks)

An apprentice has been asked to clean some machine parts using a chemical that she is not familiar with. Although her workmate has indicated that the chemical is safe, the apprentice is a little hesitant to proceed, being uncertain as to the dangers of the chemical.

- a. Why is it important for the apprentice to consult her supervisor before proceeding to clean the parts? 1 mark

- b. Apart from asking the supervisor, where else could the apprentice get reliable information about using the chemical safely? 1 mark

Question 4 (5 marks)

- a. Below is a table with descriptions of three 5S steps. The descriptions are **not** listed in the correct order.

Complete the table by writing the name of the 5S step that corresponds to each description in the space provided. 3 marks

| Description of 5S step | 5S step |
|---|---------|
| Make sure everything is clean, functioning and ready to go. | |
| Establish common ways of working to maintain the 5S system. | |
| Remove all items from the workplace that are not required for current production. | |

- b. Explain why an engineering business would implement the 5S system in its workshop. 2 marks

Question 5 (6 marks)

Figure 1 shows a machine bracket.

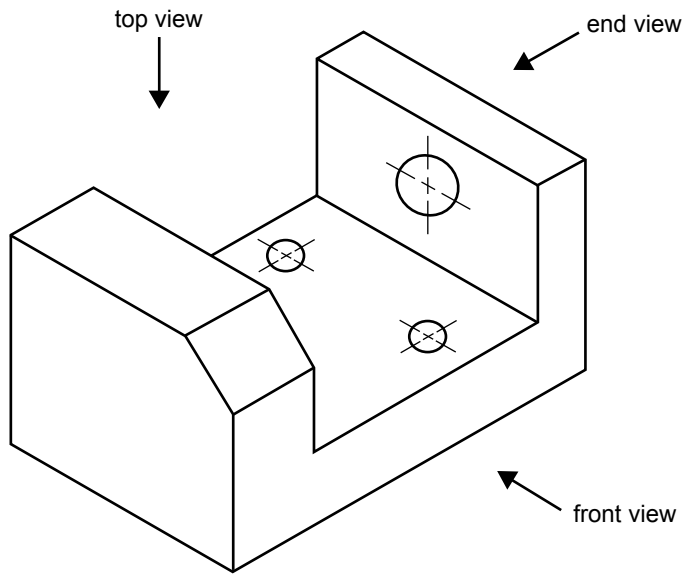

Figure 1

Sketch the machine bracket shown in Figure 1 in third-angle projection in the space provided below. Show **three** views (top, front and end), including all hidden and centre lines.

A large rectangular box is provided for sketching the machine bracket in third-angle projection. Inside the box, there are three L-shaped corner markers: one in the top-left corner, one in the bottom-left corner, and one in the bottom-right corner.

Question 6 (5 marks)

Figure 2 shows a drawing of a metal plate.

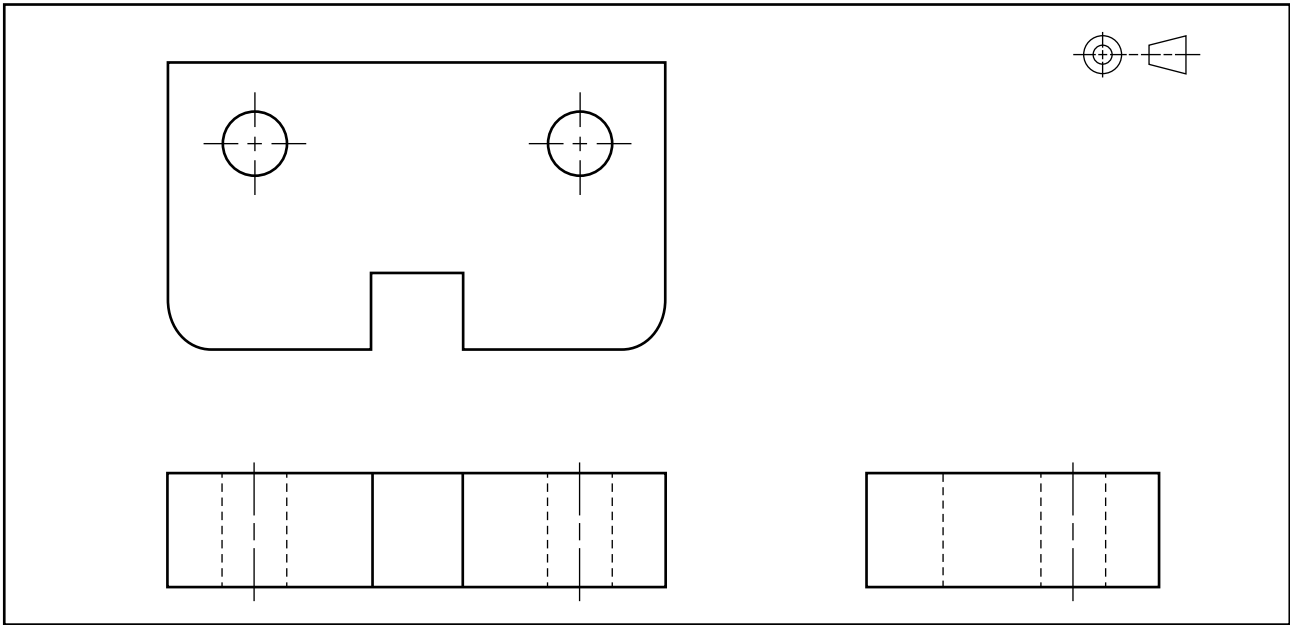
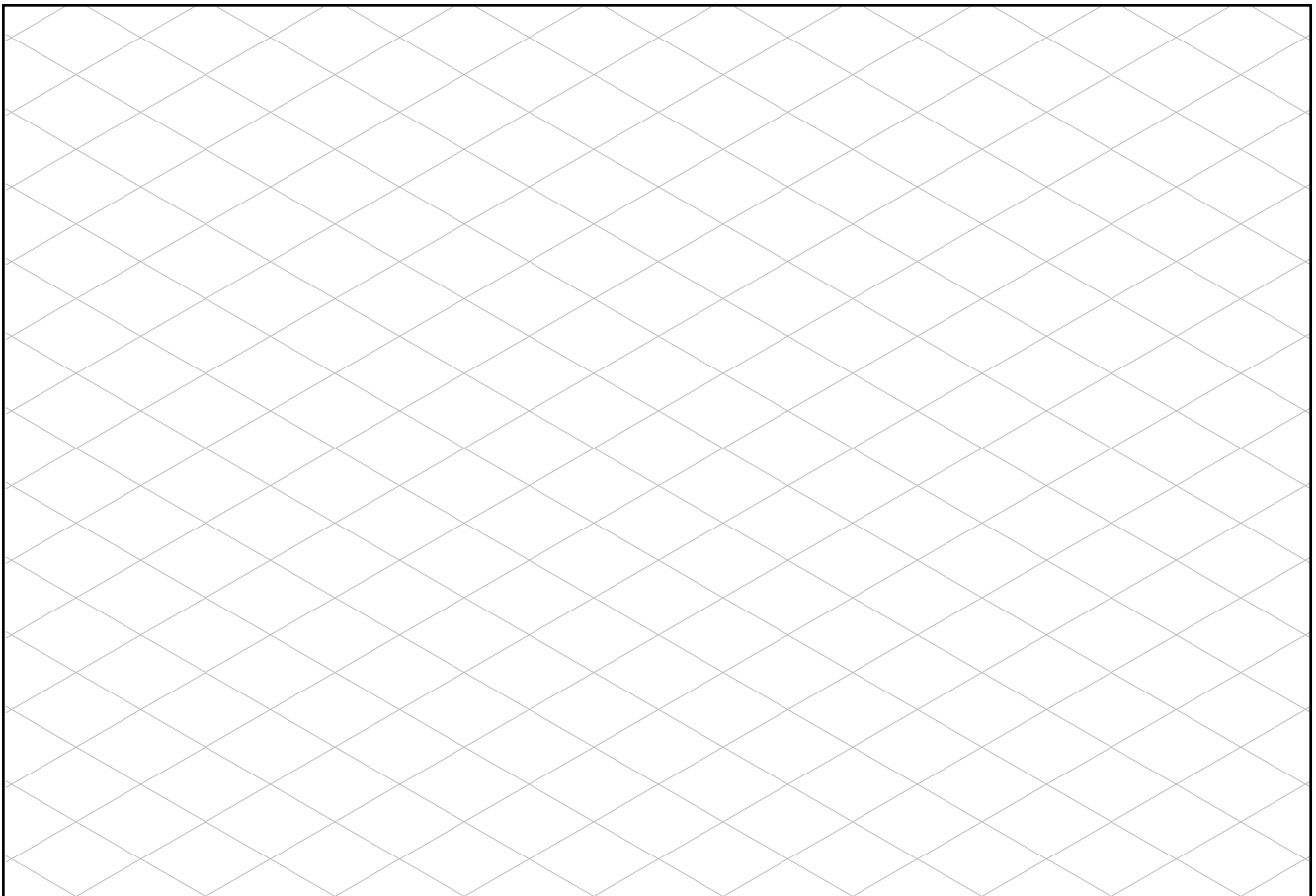

Figure 2

Sketch an isometric view of the metal plate shown in Figure 2 in the space provided below, including all centre lines.



Question 7 (5 marks)

The drawing below shows two views of a steel plate.

Correctly dimension the drawing with the following information:

- The plate is 150 mm long \times 75 mm wide \times 10 mm thick.
- The hole is 16 mm in diameter.
- The hole is positioned in the centre and is 30 mm from the left side edge.
- There is a 15 mm radius on two corners.

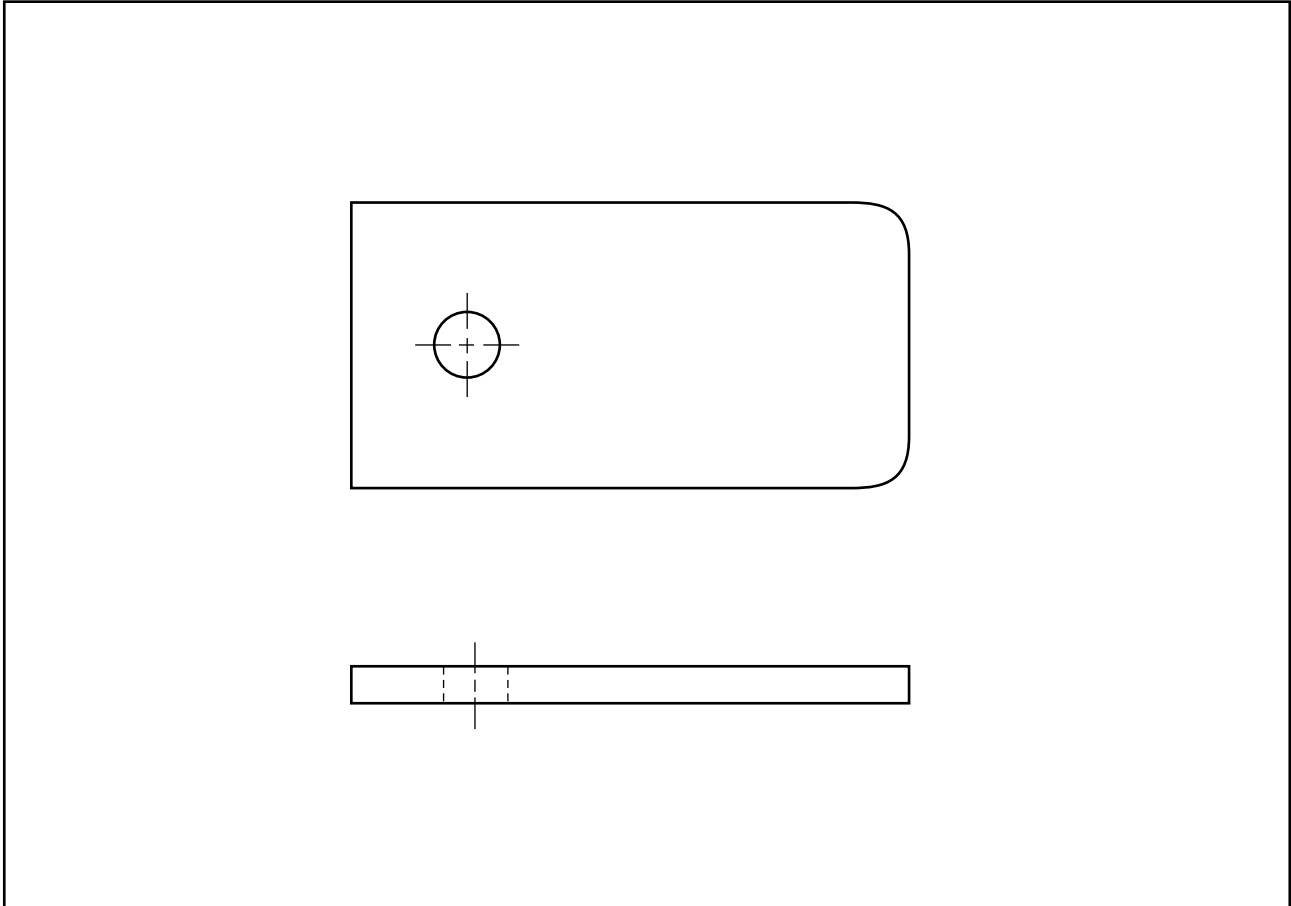

CONTINUES OVER PAGE

Question 8 (14 marks)

Adams Engineering wants to start implementing the 5S system with a team leader and six operators.

Currently, each operator has their own toolbox. An example of a typical toolbox belonging to one of the operators is shown in Figure 3.



Figure 3

After discussing the implementation of the 5S system with the team leader and his operators, it was agreed to stop the practice of storing tools in personal toolboxes.

- a. List two disadvantages of having individual operators store their tools in personal toolboxes. 2 marks

1. _____

2. _____

- b. The items in the table below were located in one of the production areas.

In the spaces provided, describe what should be done with these items during the Sort process. 4 marks

| Items | What should be done during the Sort process |
|--|---|
| a set of spanners that is used frequently for assembly | |
| two screwdrivers, not required for production, that were left in the area by the maintenance team | |
| a broken power drill that was used to deburr holes before it broke; it has since been replaced with a new one | |
| an old, large table that has two quality manuals on it and is frequently used as the table where unwanted junk is dumped | |

Some tools were placed on a shadow board, as shown in Figure 4.

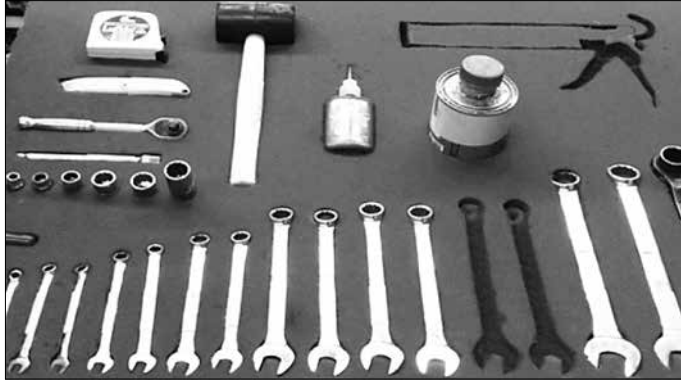

Figure 4

- c. If similar tools are used in different sections of the company, suggest **one** simple way in which the section that each tool belongs to can be easily identified.

1 mark

One of the workbenches at Adams Engineering is shown in Figure 5.



Figure 5

- d. Consider the workbench shown in Figure 5.

Describe two key issues or problems likely to be caused by working in such an environment. 2 marks

1. _____

2. _____

- e. The team leader and all six operators frequently use the workbench shown in Figure 5.

Suggest who should decide which items to keep and which items should be disposed of. Justify your answer.

2 marks

- f. A common problem with implementing the 5S system in the workplace is that it is often not sustained, with people falling back into their old habits or ways of working.

Suggest **one** approach that management at Adams Engineering could use to sustain the 5S system in the long term. Explain how your suggestion could help to sustain the 5S system.

3 marks

Question 9 (4 marks)

The following bar graph shows the number of reject parts from a manufacturing company over a 12-month period.

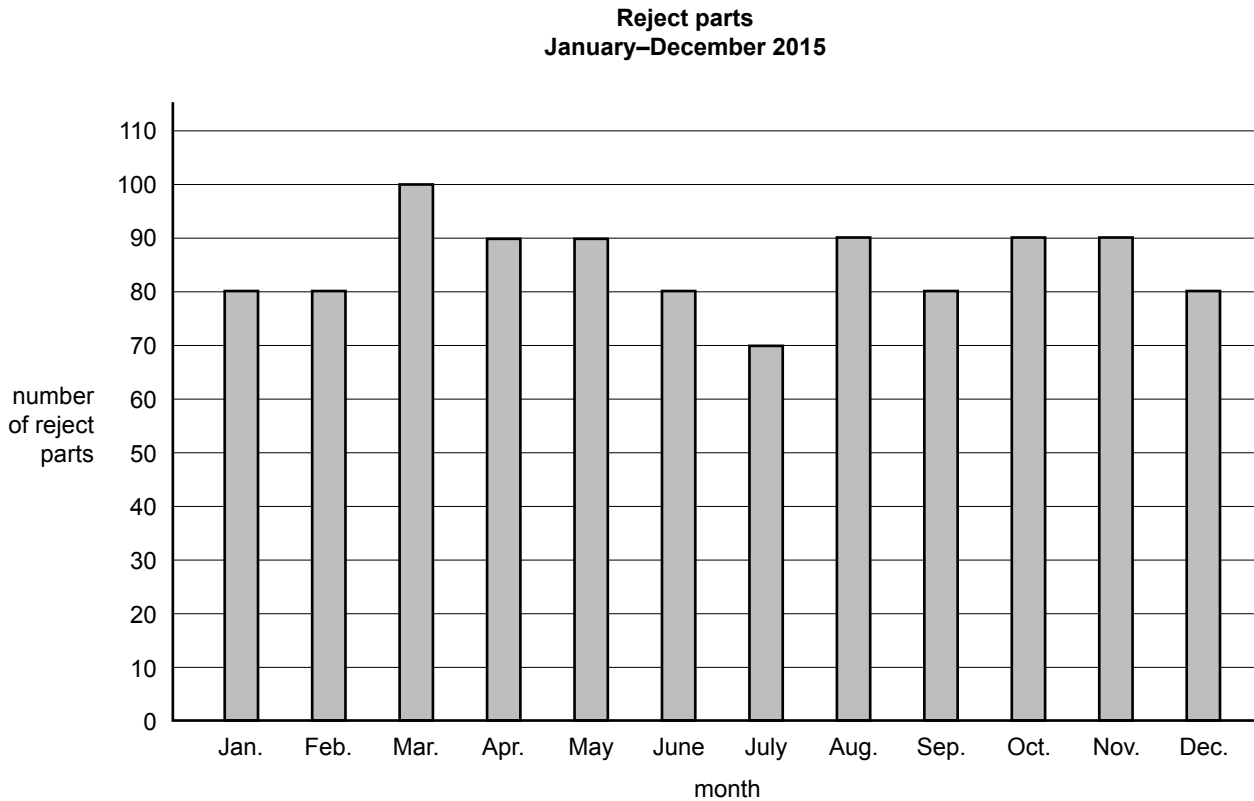

- a. Which month had the lowest number of reject parts? 1 mark

- b. What is the total number of reject parts for the year? 1 mark

- c. If the company made a total of 50 000 parts for the year, calculate the percentage of parts that were rejected. 2 marks

Question 10 (3 marks)

Figure 6 shows an operator using a lathe in an engineering workshop.

Identify three potential safety hazards shown in Figure 6.

1. _____
2. _____
3. _____



Figure 6

Question 11 (7 marks)

Pieces of steel checker plate measuring $0.59 \text{ m} \times 0.28 \text{ m}$ are used by a company to make boat trailers.

- a. Describe **one** disadvantage of using steel for this application. 1 mark
-
- b. Suggest a more suitable material to use in the construction of boat trailers. 1 mark
-
- c. What is the maximum number of pieces of the steel checker plate that could be cut from a $2.4 \text{ m} \times 1.2 \text{ m}$ sheet? 1 mark
-
- d. After cutting the pieces from the $2.4 \text{ m} \times 1.2 \text{ m}$ sheet, there was 0.36 m^2 of waste left over. What percentage of the total sheet is this? 2 marks
-
-
-
- e. The waste from **part d.** was placed in the scrap metal recycling bin shown in Figure 7. The total weight of the full bin is 723 kg. The empty bin weighs 73 kg.



Figure 7

Calculate how much money the company would receive for the scrap metal in the bin shown above if it is full and if the amount paid for scrap metal is 15 cents per kilogram. 2 marks

Question 12 (3 marks)

Figure 8 shows an operator lifting a piece of sheet metal onto a laser bed for cutting.



Figure 8

- a. Identify two potential safety hazards, other than lifting, in Figure 8. 2 marks

1. _____

2. _____

- b. Suggest an appropriate way for the sheet metal to be safely lifted onto the laser bed. 1 mark

Question 13 (2 marks)**Figure 9**

Figure 9 shows an operator drilling a piece of material.

Describe two precautions that should be taken by the operator to make the drilling operation safer.

1. _____

2. _____

Question 14 (5 marks)

A variety of personal protective equipment (PPE) items are shown below.



Sources: top row, from left: tale/Shutterstock.com, Photo Melon/Shutterstock.com, indigolotos/Shutterstock.com;
 centre row, from left: Alex459/Shutterstock.com, Africa Studio/Shutterstock.com, 79mtk/Shutterstock.com;
 bottom row, from left: Crepesoles/Shutterstock.com, YoLusZam1802/Shutterstock.com,
 Everything/Shutterstock.com

From the PPE items shown above, select and name two essential items that would be necessary to safely perform each of the tasks listed in the table below.

| Task | Essential PPE items |
|------------------------------------|----------------------------|
| using an angle grinder | 1. |
| | 2. |
| walking through a warehouse | 1. |
| | 2. |
| welding | 1. |
| | 2. |
| drilling holes using a bench drill | 1. |
| | 2. |
| pouring chemicals | 1. |
| | 2. |

Question 15 (1 mark)

The tolerance of the shaft shown in Figure 10 is ± 0.05

**Figure 10**

What does this tolerance mean?

Question 16 (6 marks)

The table below gives a list of environmental actions that a company is considering.

Suggest how each action could be an advantage to the company and indicate the potential advantage to the environment in each case.

| Action | Advantage to company | Potential advantage to environment |
|--|----------------------|------------------------------------|
| installing solar panels | | |
| installing a rainwater tank | | |
| installing ceiling insulation in the office area | | |

Question 17 (2 marks)

At a recent company meeting, a manager reported that in the previous six months, the company had experienced the following safety issues:

- 15 near misses
- 7 minor injuries
- 2 major injuries

Construct a bar graph on the grid provided below to represent the data above.

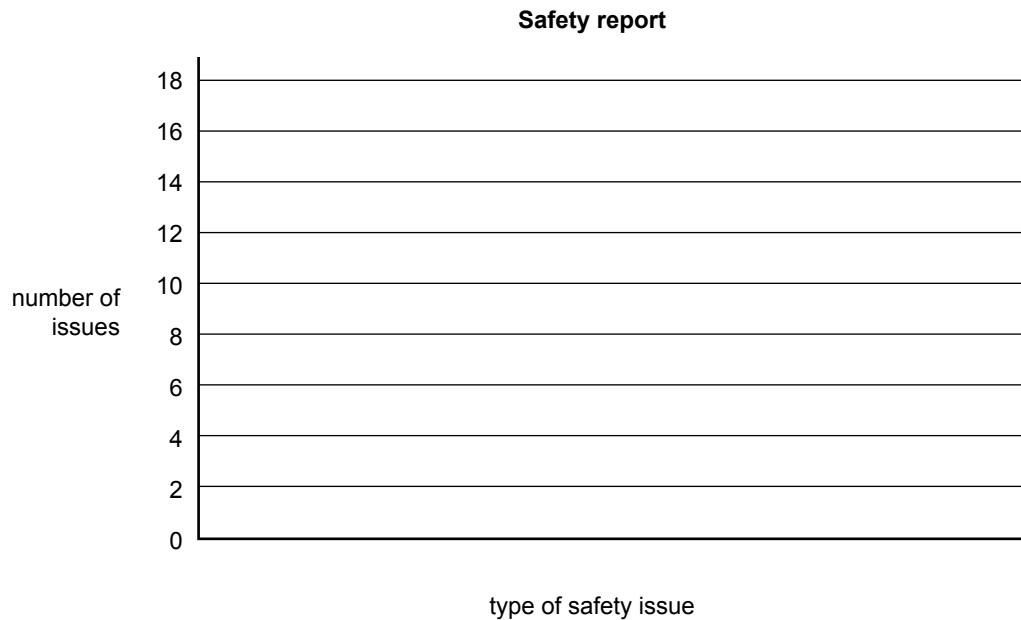

Question 18 (4 marks)

An inspection area in a company is used only occasionally; however, the lights in this area are turned on in the morning and left on until the end of each day.

Data was collected over a five-day period to establish how often the inspection area was **not** used by the company's employees. The results are shown in the table below.

| Date | Time of monitoring | Total time lights left on | Time lights were on when area not in use |
|----------------|--------------------|---------------------------|--|
| Monday 16th | 7.00 am – 5.00 pm | 10 hours | 4.5 hours |
| Tuesday 17th | 7.00 am – 5.00 pm | 10 hours | 3 hours |
| Wednesday 18th | 7.00 am – 5.00 pm | 10 hours | 3.5 hours |
| Thursday 19th | 7.00 am – 5.00 pm | 10 hours | 3 hours |
| Friday 20th | 7.00 am – 5.00 pm | 10 hours | 4 hours |

- a. Based on the figures above, calculate how long the lights are left on over a year when the area is not in use. (The company does not shut down and operates for 52 weeks of the year.) 2 marks

- b. Suggest what could be done so that the lights are on only when the area is being used and indicate how this would benefit the company. 2 marks
