

Instructions

Answer **all** questions in the spaces provided.
 All dimensions are in millimetres (mm) except where specified.
 Unless otherwise indicated, the diagrams in this book are **not** drawn to scale.

Question 1 (3 marks)

- a. CAD software is often used when creating drawings for engineering purposes.

What does CAD stand for?

1 mark

- b. Suggest one advantage and one disadvantage of using CAD software to produce engineering drawings, and give your reasoning for each response.



2 marks

Advantage _____

Disadvantage _____

Question 2 (4 marks)

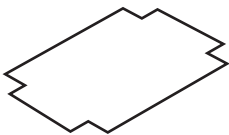
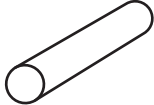
In the table below, indicate the **most** suitable hand tool to use for each task.

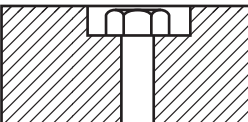
	Task	Hand tool
	cutting out corners of 0.8 mm thick sheet metal	
	cutting a piece of Ø 12 mild steel bar	
	bending Ø 3 wire	
	tightening a nut below the surface	

Question 3 (3 marks)

- a. Correct personal protective equipment (PPE) should be worn when welding.

Other than safety boots, what are **two** specific items of PPE that should be worn when welding?

1 mark

- b. Safety is paramount when welding.

Other than wearing PPE, give two things that should be checked and/or prepared **before** welding is started in order to minimise risks to the **operator** and **others** in the area.

2 marks

1. _____

2. _____

Question 4 (2 marks)

In a manufacturing company, poor-quality work can result in rework (components being re-machined), which is wasteful and costly.

What are two specific costs that are associated with this rework?

1. _____

2. _____

Question 5 (4 marks)

Figure 1 shows a photo of a centre lathe. Four parts have been labelled A, B, C and D.

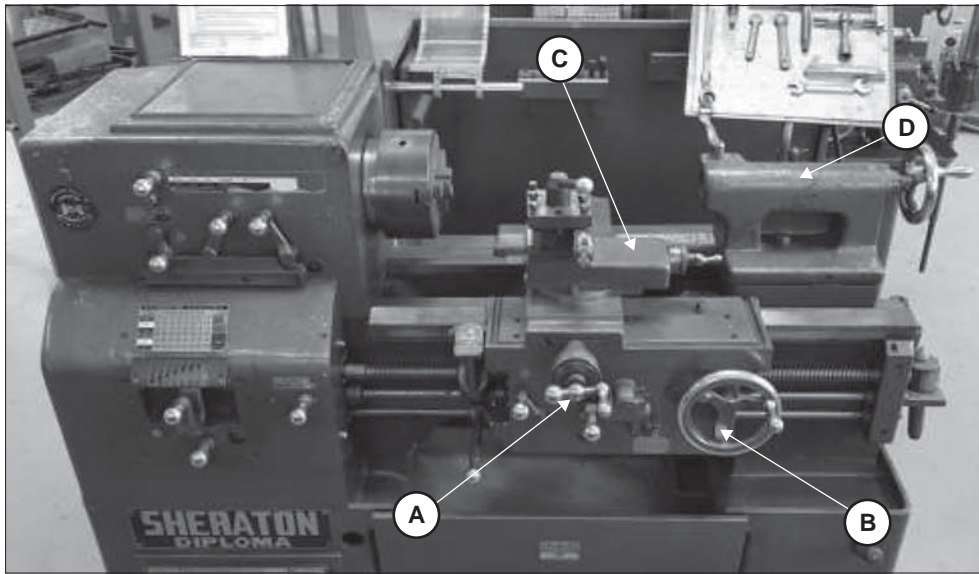

Figure 1

The table below gives the names of the four labelled parts.

Describe one main function or use of each part.

Part		Function or use
A	cross slide hand wheel	
B	carriage hand wheel	
C	top slide	
D	tailstock	

Question 6 (3 marks)

Three diagrams of steel shapes typically used in engineering are shown below.

Write the correct name of each steel shape in the space provided.



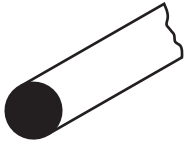

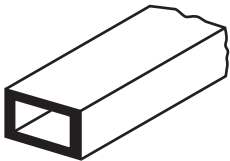

Question 7 (1 mark)

The formula for calculating depth of thread is

$$\text{depth of thread} = 0.614 \times \text{pitch}$$

Calculate the depth of thread for an M12 \times 1.25 screw.

Question 8 (1 mark)

Figure 2

Determine the size of the spanner required for the bolt shown in Figure 2.

TURN OVER

Question 9 (7 marks)

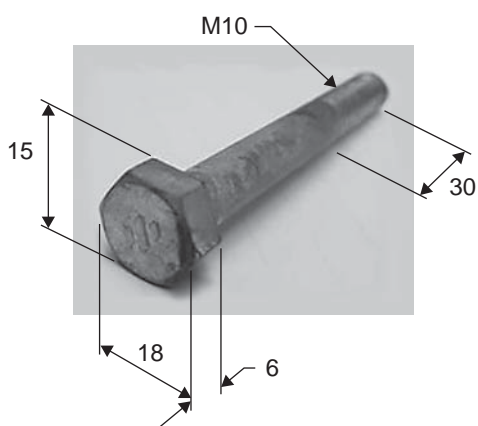
The steel block in Figure 3 requires two blind holes to be drilled and tapped.

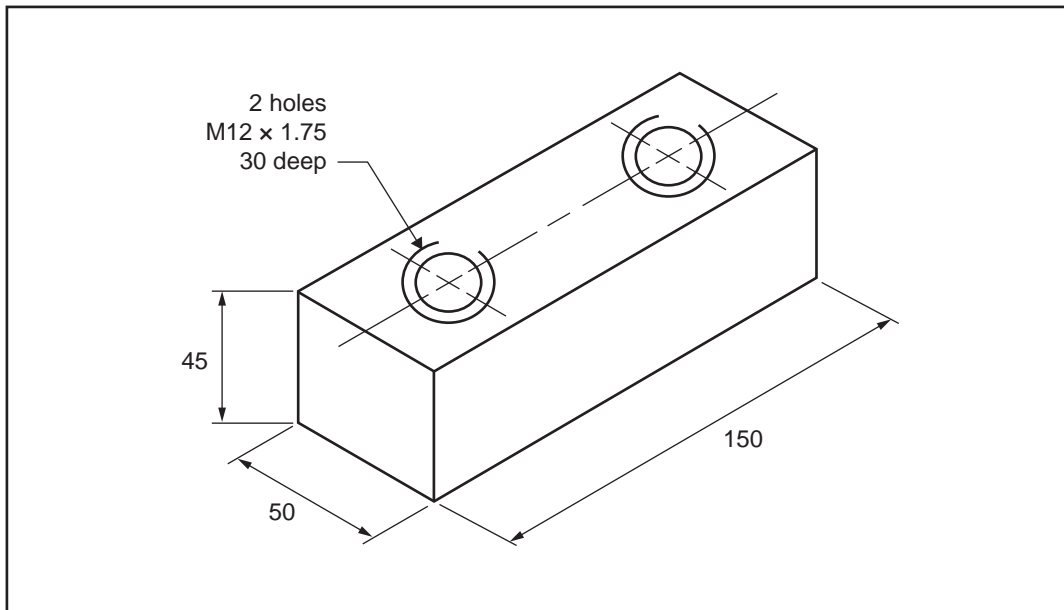

Figure 3

Table 1 shows a tapping chart for ISO metric coarse threads.

Table 1

ISO metric coarse threads							
Note: All dimensions are in millimetres.							
Outside diameter	Core	Pitch	Depth	Flat	Effective diameter	Tapping drill	Clearance drill
1.6	1.1706	0.35	0.2147	0.04375	1.373	1.25	1.65
1.8	1.3706	0.35	0.2147	0.04375	1.573	1.45	1.85
2.0	1.5092	0.40	0.2454	0.05000	1.740	1.60	2.05
2.2	1.6480	0.45	0.2760	0.05625	1.908	1.75	2.25
2.5	1.9480	0.45	0.2760	0.05625	2.208	2.05	2.60
3.0	2.3866	0.50	0.3067	0.06250	2.675	2.50	3.10
3.5	2.7638	0.60	0.3681	0.07500	3.110	2.90	3.60
4.0	3.1412	0.70	0.4294	0.08750	3.545	3.30	4.10
4.5	3.5798	0.75	0.4601	0.09375	4.013	3.80	4.60
5.0	4.0184	0.80	0.4908	0.10000	4.480	4.20	5.10
6.0	4.7732	1.00	0.6134	0.12500	5.350	5.00	6.10
7.0	5.7732	1.00	0.6134	0.12500	6.350	6.00	7.20
8.0	6.4664	1.25	0.7668	0.15625	7.188	6.80	8.20
10.0	8.1596	1.50	0.9202	0.18750	9.026	8.50	10.20
12.0	9.8530	1.75	1.0735	0.21875	10.863	10.20	12.20
14.0	11.5462	2.00	1.2269	0.25000	12.701	12.00	14.25
16.0	13.5462	2.00	1.2269	0.25000	14.701	14.00	16.25
18.0	14.9328	2.50	1.5336	0.31250	16.376	15.50	18.25
20.0	16.9328	2.50	1.5336	0.31250	18.376	17.50	20.25
22.0	18.9328	2.50	1.5336	0.31250	20.376	19.50	22.25
24.0	20.3194	3.00	1.8403	0.37500	22.051	21.00	24.25

- a. Use the tapping chart in Table 1 to determine the correct drill size for the holes shown in Figure 3. 1 mark

- b. What should be done to the steel block before drilling in order to stop the drill from wandering off the marked lines? 1 mark

- c. Figure 4 shows a set of hand taps that will be used to tap the two blind holes of the steel block shown in Figure 3.



Source: Sugrit Jiranarak/Shutterstock.com

Figure 4

- i. Number the taps to show the sequence in which they should be used by writing 1, 2 and 3 in the boxes provided in Figure 4. 1 mark

- ii. Justify the sequence you have numbered in Figure 4. 2 marks

- d. When hand tapping, the tap should be regularly turned in reverse before continuing to tap. Why is this the recommended procedure? 1 mark

- e. When drilling, it is important that the drill rotates at the correct number of revolutions per minute (RPM). Identify **one** major factor that determines the correct RPM for a drill. 1 mark

TURN OVER

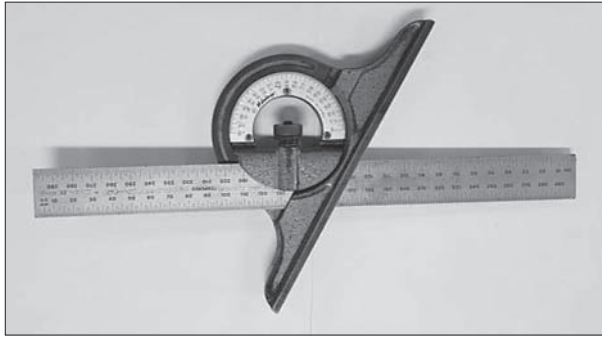
Question 10 (1 mark)**Figure 5**

Name the tool shown in Figure 5 and indicate what it is commonly used for.

Question 11 (1 mark)

What is the difference between a tap and a die in the context of cutting threads?

Question 12 (2 marks)

a. Describe the difference between plain bearings and anti-friction bearings.

1 mark

b. Plain bearings can be made from a range of materials.

List **one** material that is suitable to use when making a plain bearing.

1 mark

Question 13 (2 marks)

An assembly worker takes 16 minutes to assemble one component in a production line.

How many components could this worker assemble in an eight-hour shift, not taking breaks into account?

Question 14 (3 marks)

A number of factors should be considered when deciding on the type of material to use to make a component.

List three factors that should be considered when selecting a suitable type of material.

1. _____
2. _____
3. _____

Question 15 (5 marks)

Figure 6 shows a bracket.

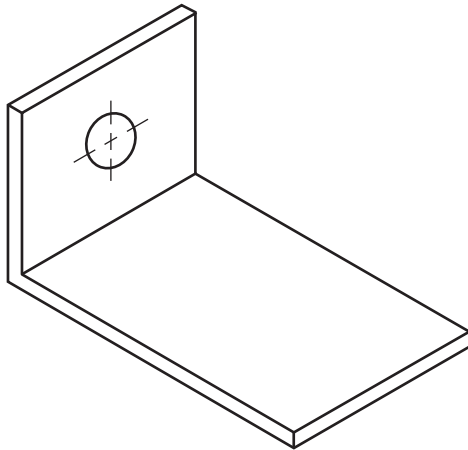
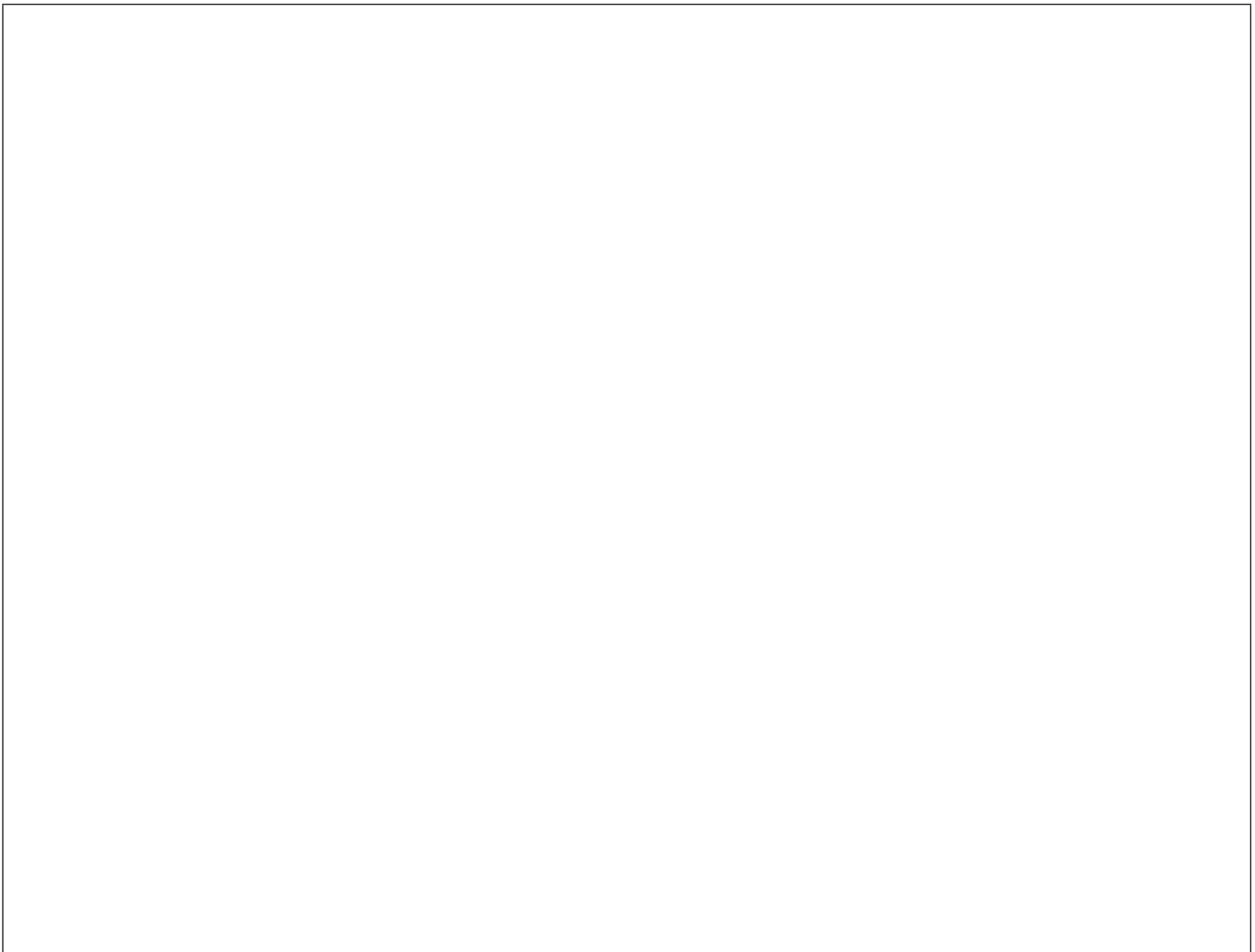

Figure 6

Dimensions of the bracket:

- 50 mm wide
- 80 mm long
- 40 mm high
- 5 mm thick
- hole has a 10 mm diameter and is in the middle of the plate

In the space provided below, sketch **two** views of the bracket shown in Figure 6 using third-angle projection. Include all dimensions that are required to make the bracket. You are not required to draw the sketch to scale.



CONTINUES OVER PAGE

TURN OVER

Question 16 (2 marks)

Figure 7 shows a plate that has been drawn to show a sectional view.

On Figure 7, complete the side view of the plate, showing Section A-A.

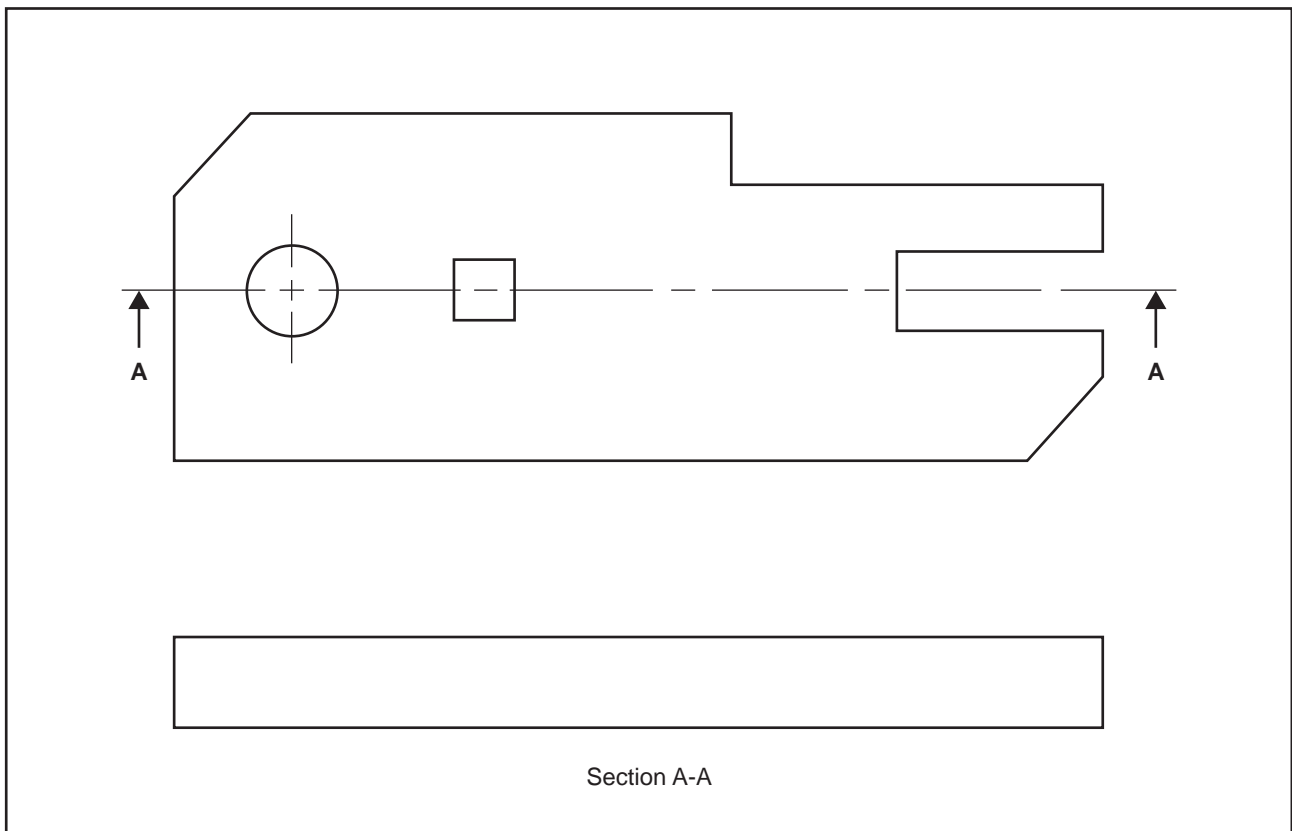

Figure 7

Question 17 (1 mark)

Figure 8 shows a sling typically used in an engineering workshop.



Figure 8

Why would it be safe to use the sling shown in Figure 8 to lift a load weighing 2250 kg?

Question 18 (15 marks)

Figure 9 shows a basic drawing of a child’s pull-along wagon. The following questions relate to the design and manufacture of the pull-along wagon.

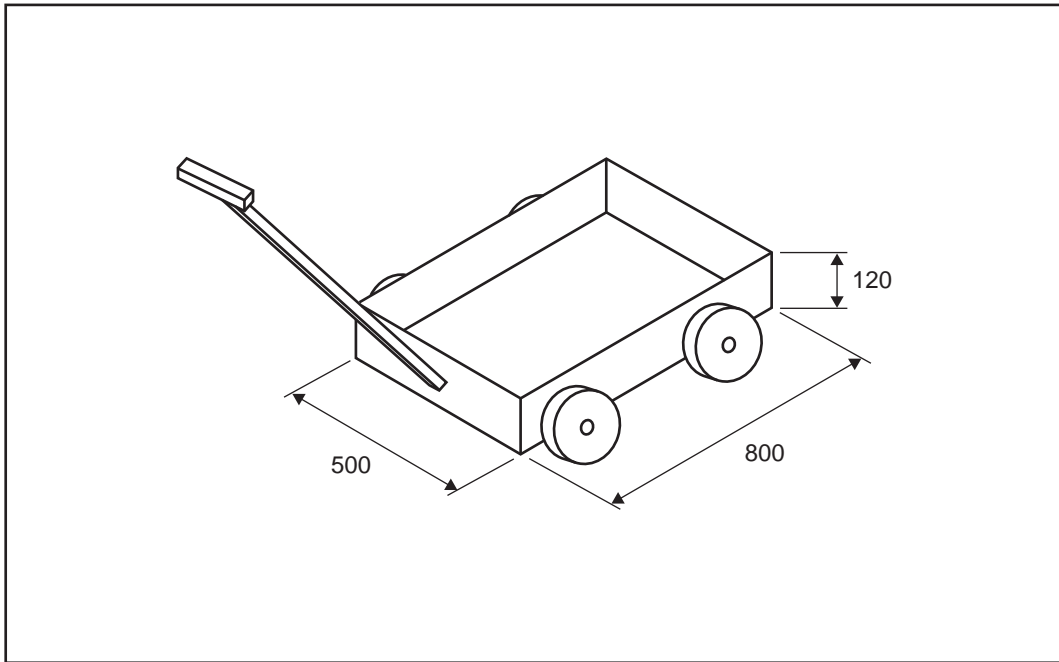

Figure 9

The base of the pull-along wagon will be made from 1.55 mm thick mild steel sheet metal.

The flat profile will be cut as a single piece. The four sides will be folded and then spot welded together to make the rectangular base, as shown in Figure 9.

a. Sketch the following in the space provided below:

- the flat profile of the base
- the tabs required for the spot welding

Include all required dimensions to make the base.

3 marks

- b. Spot welding the base is only one method of joining the corners.

Suggest two types of fasteners that could be used to join the corners instead of spot welding. 2 marks

1. _____

2. _____

- c. Figure 10 shows a drawing of an axle and a wheel that will be used on the pull-along wagon.

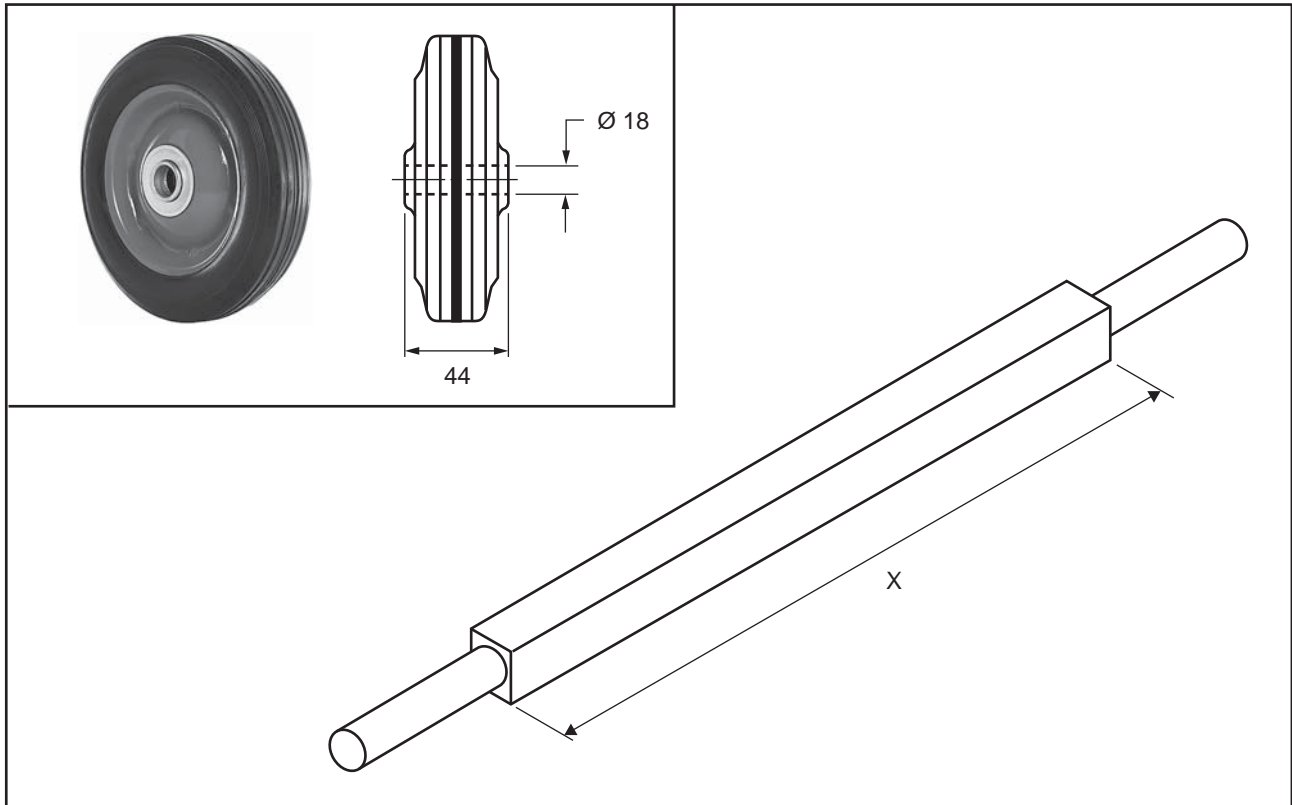

Source: Richard Peterson/Shutterstock.com (wheel image)

Figure 10

Taking into consideration the design of the wheel, determine the length of dimension X.

1 mark

d. Figure 11 shows a sketch of one end of the axle shown in Figure 10.

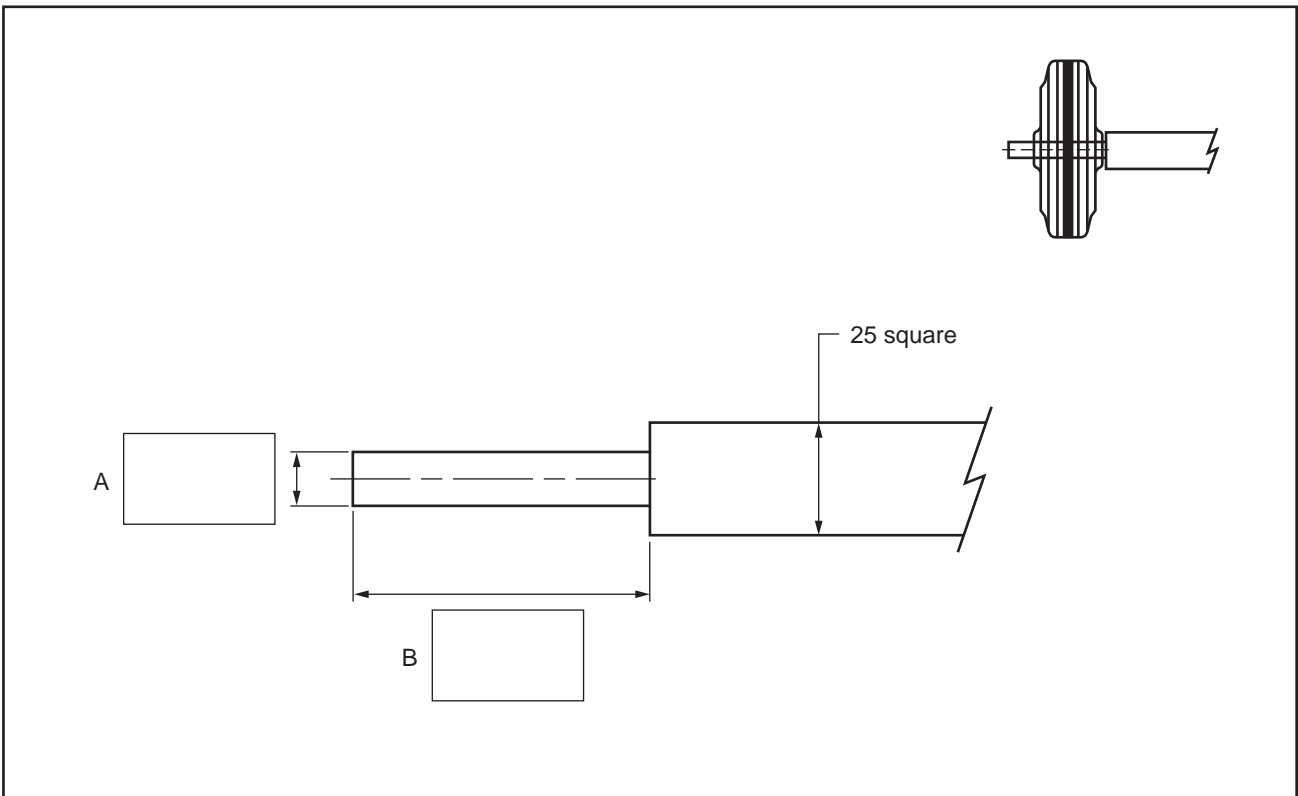

Figure 11

i. Complete the drawing of the end of the axle shown in Figure 11 by adding the two missing dimensions, A and B, in the boxes provided and by drawing a design for a way of securing the wheel to the axle. 3 marks

ii. Provide a description of your design. 1 mark

e. The axle will be made from 25 mm square steel on a lathe.
 What is the **best** work holding method to turn the diameter A in Figure 11 for this task? 1 mark

- f. The handle of the pull-along wagon needs to be attached in a way that allows it to move up and down, as shown by the arrow in Figure 12.

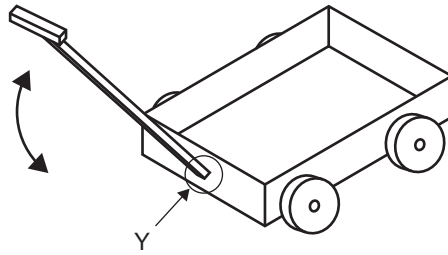

Figure 12

The handle needs to be attached to the pull-along wagon at the position labelled 'Y'.



Sketch a potential design for attaching the handle to the pull-along wagon and label aspects of your design in the space provided below.

4 marks

Question 19 (3 marks)

The tools in the table below are all used to machine holes.

Describe the **specific** purpose of each tool when machining holes.

Tool	Specific purpose
	
	
	

Question 20 (3 marks)

The shape shown in Figure 13 will be marked out on a 200 mm square aluminium plate.

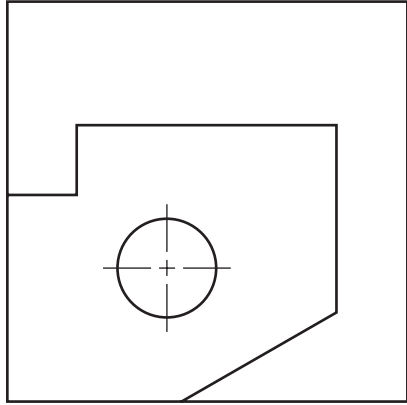

Figure 13

- a. Describe what could be done to the surface of the aluminium plate to make the marked lines stand out clearly. 1 mark

- b. Name four marking-out tools that would be required to mark out the shape shown in Figure 13. 2 marks

1. _____

2. _____

3. _____

4. _____

Question 22 (3 marks)

Figure 15 shows a shaft with a taper that needs to be machined.

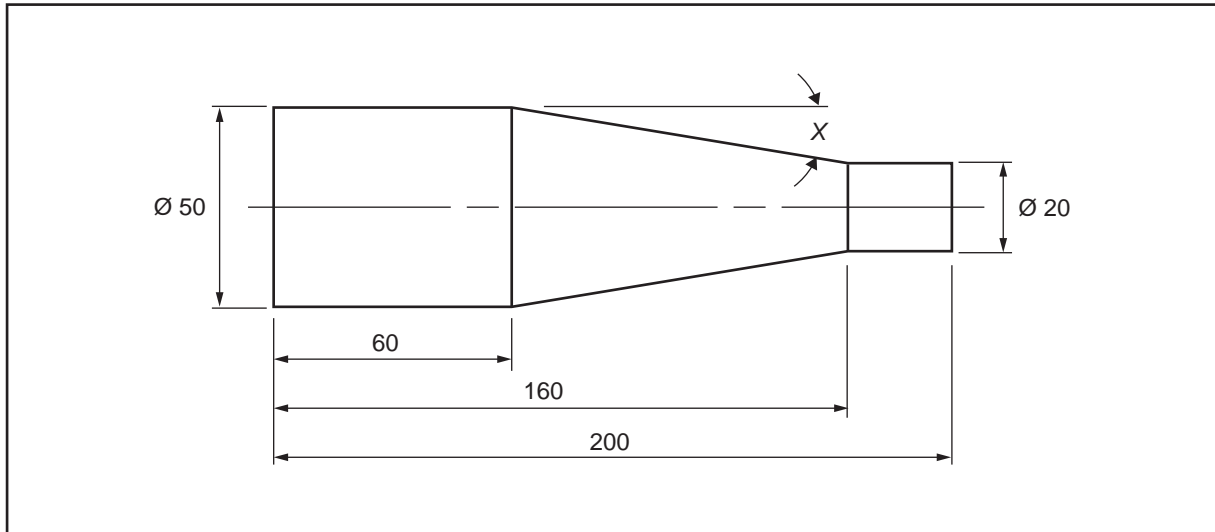

Figure 15

Calculate the angle of the taper, X , in Figure 15. Show your working.

Question 23 (6 marks)

Figure 16 shows a triangle, ABC , that is to be made into a plastic end cover for a guard.

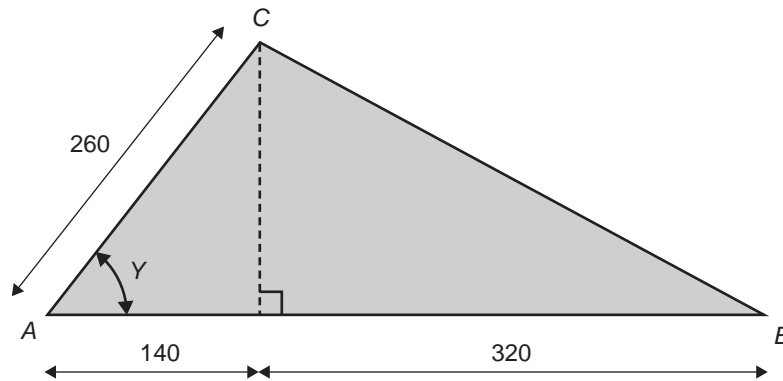

Figure 16

- a. Calculate the angle Y of the end cover shown in Figure 16. Show your working. 2 marks

- b. Two end covers will be guillotined from a single piece of rectangular plastic, as shown in Figure 17 below.

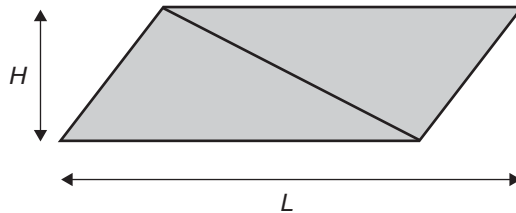

Figure 17

Calculate the minimum size of a piece of plastic ($L \times H$), to be cut from the piece of plastic shown in Figure 17, that would be required to make the two end covers. 3 marks

- c. Name **one** method, other than mechanical fasteners, that can be used to join plastics together. 1 mark

Question 24 (5 marks)

The bin shown in Figure 18 is used to store scrap aluminium in an engineering workshop. Twenty-four of these bins are located in one area inside the factory so that operators can take a bin to use whenever one is required.

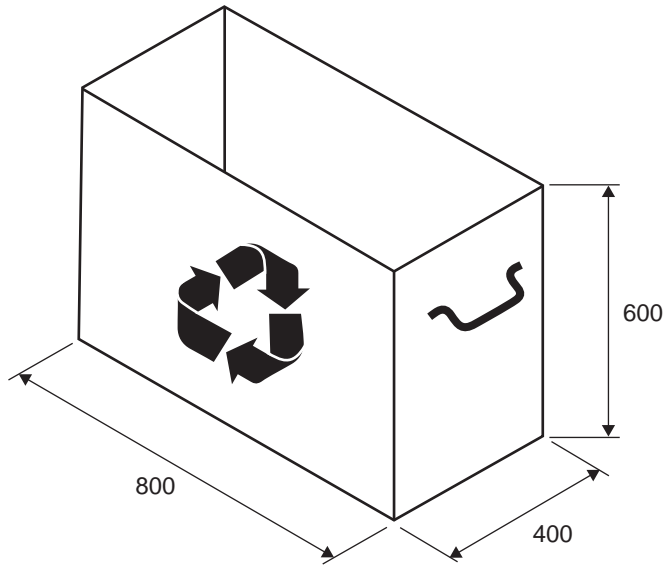

Figure 18

- a. If the 24 bins in the factory are stored side by side in three rows of eight, calculate the area of floor space, in square metres, required to store the 24 bins. Show your working. 2 marks

- b. The bins are to be emptied into a larger 3 m³ bin that is to be taken offsite. How many bins will it take to fill the 3 m³ bin? Show your working. 2 marks

c.



What does the symbol above indicate? 1 mark

Question 25 (16 marks)

Figure 19 shows the design for a spit barbecue, which allows meat to turn as it is cooking.

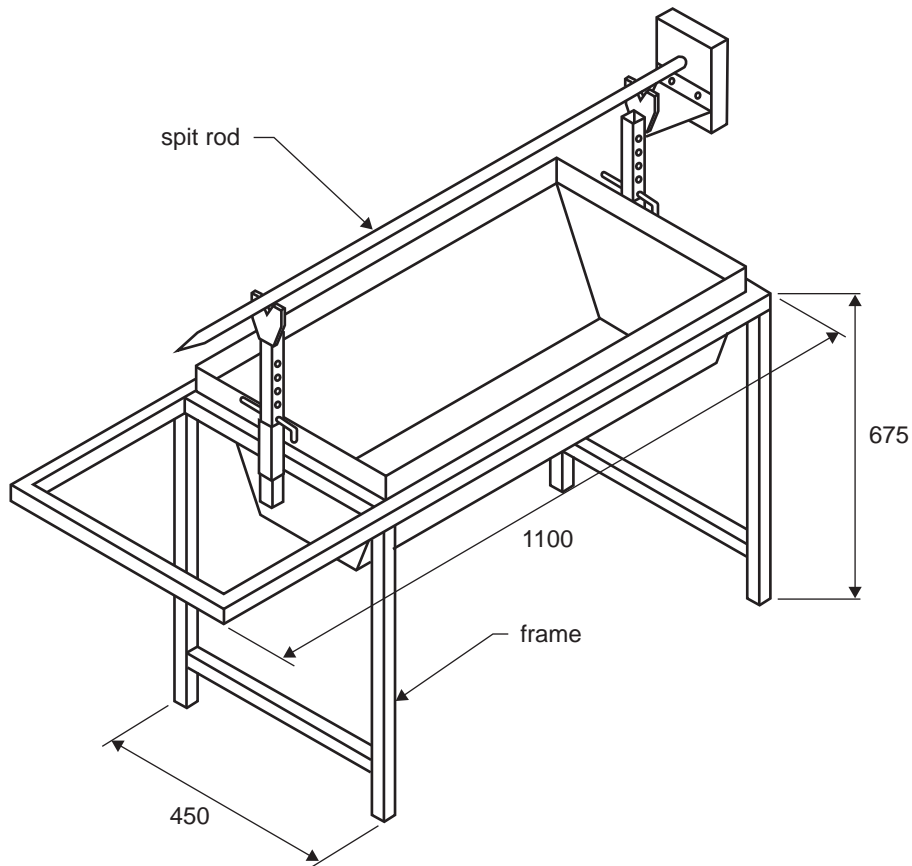

Figure 19

The frame of the spit barbecue will be made from 25 mm square tubing, with the overall dimensions of 1100 mm × 450 mm × 675 mm, as shown in Figure 19.

- a. Calculate the total length, in metres, of the square tubing that would be required to make **one** spit barbecue as shown in Figure 19. Show your working. 3 marks

- b. The spit rod is used to hold the meat while it is cooking.
Suggest a suitable type of material that could be used to make the spit rod. Give a reason for your answer. 1 mark

Figure 20 shows the adjustable rail that will be used for the spit barbecue.

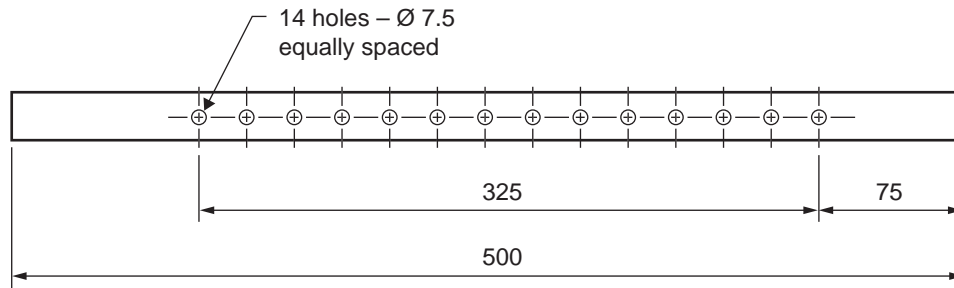

Figure 20

- c. Determine the centre distance between each of the holes in the adjustable rail. 1 mark
-
- d. When drilling the holes, the adjustable rail will be held in a vice that has a solid base, as shown in Figure 21.

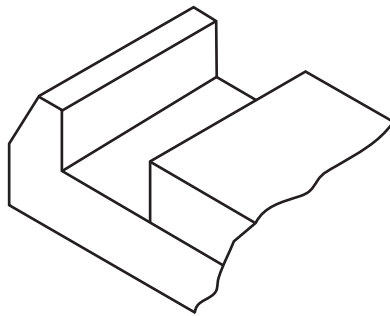

Figure 21

What could be done to make sure that the drill does not damage the base of the vice when drilling the holes?

1 mark

- e. Calculate the RPM of the drill required to create the holes in the adjustable rail, using a cutting speed of 35 m/min and the following formula for RPM. 2 marks

$$\text{RPM} = \frac{320v}{d}, \text{ where } v = \text{cutting speed and } d = \text{diameter}$$

- f. The drill used to create the holes was found to be blunt and required sharpening using an off-hand grinder.
 A grinder will occasionally need basic adjustment and/or maintenance due to wear of the wheels over time.
 Describe one adjustment and one form of maintenance that would need to be made to the off-hand grinder to keep the off-hand grinder in good condition and to ensure it is safe to use. 2 marks

Adjustment _____

Maintenance _____

- g. The diagram below shows the support bracket that holds the spit rod.
 As shown in the design in Figure 19, the spit rod currently sits in a pair of V-shaped support brackets as it rotates, but this design has been observed to cause wear on both the rod and the support brackets.
 Sketch a potential design change that could be made to eliminate wear on the support brackets as the spit rod rotates and label aspects of your design change in the space provided below. 3 marks

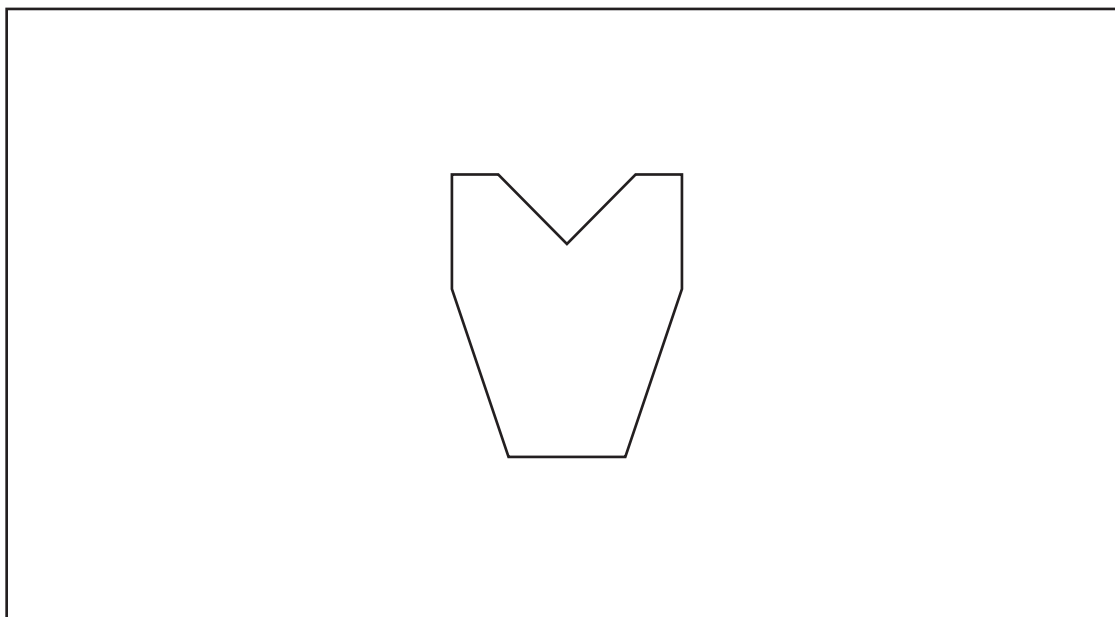

- h.** The body of the spit barbecue will be made from 1.52 mm thick sheet metal. This sheet metal comes in 1200 mm × 2400 mm sheets.

Table 2 shows the properties of a range of sheet metal gauges.

Table 2

Gauge	Thickness (inches)	Thickness (mm)	Weight (kg/m²)
20	0.0375	0.91	7.3
19	0.0438	1.06	8.5
18	0.0500	1.21	9.7
17	0.0563	1.37	10.9
16	0.0625	1.52	12.1
15	0.0703	1.71	13.6
14	0.0781	1.90	15.1
13	0.0938	2.28	18.2
12	0.1094	2.66	21.2
11	0.1250	3.04	24.2
10	0.1406	3.42	27.2

Use Table 2 to calculate the total weight of five sheets. Give your answer correct to two decimal places.

2 marks

- i. Figure 22 shows one piece of the 1200 mm × 2400 mm sheet metal. This piece is shown on the floor, leaning against a bench in a workshop that does not have a crane.



Figure 22

Describe **one** safe way to move the piece of sheet metal shown in Figure 22 to a guillotine located 3 m away from the bench it is currently leaning against.

1 mark
