

STUDENT NUMBER Letter

VCE VET ENGINEERING STUDIES

Written examination

Thursday 10 November 2022

Reading time: 9.00 am to 9.15 am (15 minutes)

Writing time: 9.15 am to 10.45 am (1 hour 30 minutes)

QUESTION AND ANSWER BOOK

Structure of book

<i>Number of questions</i>	<i>Number of questions to be answered</i>	<i>Number of marks</i>
23	23	100

- Students are permitted to bring into the examination room: pens, pencils, highlighters, erasers, sharpeners, rulers, one scientific calculator, a protractor, a set square and aids for curve sketching.
- Students are NOT permitted to bring into the examination room: blank sheets of paper and/or correction fluid/tape.

Materials supplied

- Question and answer book of 28 pages

Instructions

- Write your **student number** in the space provided above on this page.
- Unless otherwise indicated, the diagrams in this book are **not** drawn to scale.
- All written responses must be in English.

Students are NOT permitted to bring mobile phones and/or any other unauthorised electronic devices into the examination room.

Instructions

Answer **all** questions in the spaces provided.

All dimensions are in millimetres (mm) except where specified.

Unless otherwise indicated, the diagrams in this book are **not** drawn to scale.

Question 1 (3 marks)

When operating a milling machine, personal protective equipment (PPE) is worn to protect the operator from hazards.

Complete the table below by listing three different types of PPE that should be used when operating a milling machine and state the hazard that each type of PPE protects the operator from.

Type of PPE	Hazard

Question 2 (3 marks)**Figure 1**

Figure 1 shows a lathe that has been set up to machine grooves at the end of a workpiece, indicated by the white circle. The set-up shown is not yet safe for machining.

List three safety issues that would need to be corrected before starting the lathe.

1. _____
2. _____
3. _____

TURN OVER

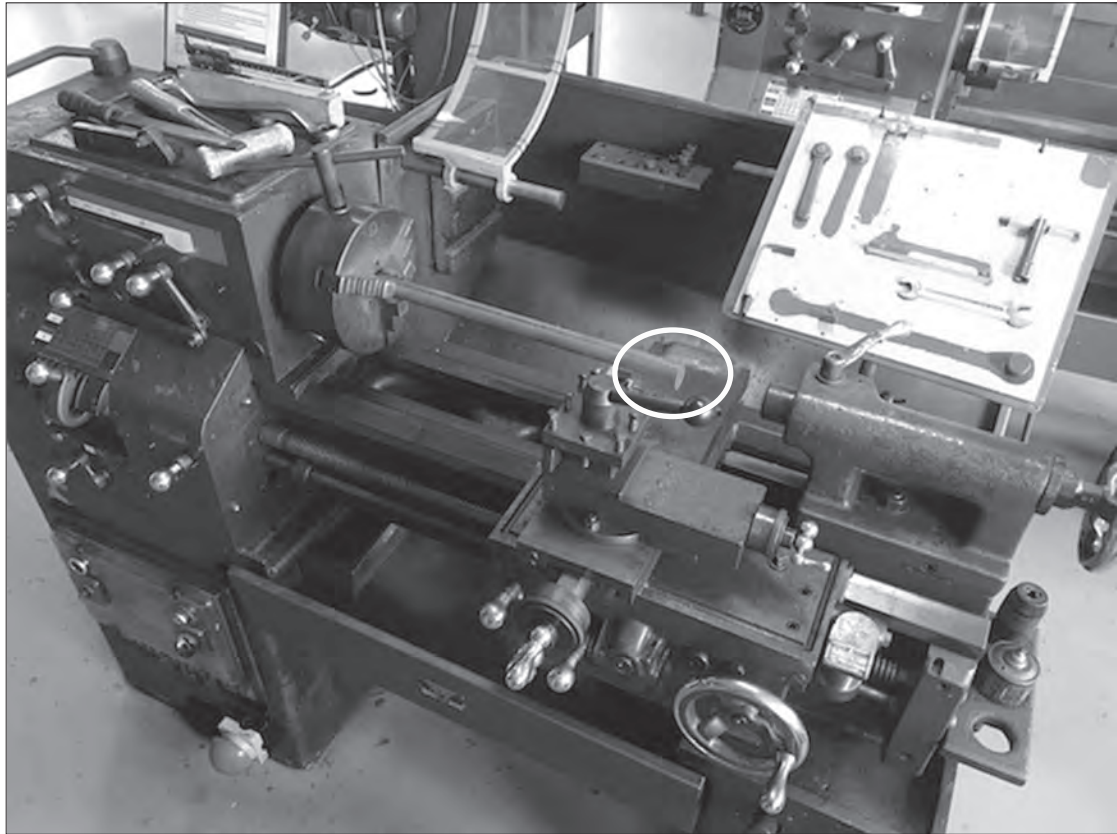
Question 3 (3 marks)



Figure 2

- a.** Name the tool shown in Figure 2. 1 mark

- b.** State two common engineering uses of the tool shown in Figure 2. 2 marks

1. _____

2. _____

Question 4 (2 marks)

Figure 3 shows a safety sign commonly found in engineering workshops.



Figure 3

- a.** What does the safety sign shown in Figure 3 mean? 1 mark

- b.** For what workplace task would the safety sign shown in Figure 3 be relevant? 1 mark

DO NOT WRITE IN THIS AREA

Question 5 (2 marks)

Metals used in engineering can be categorised as ferrous or non-ferrous.

Complete the table below by listing two ferrous and two non-ferrous metals.

Ferrous metal	Non-ferrous metal

Question 6 (1 mark)

Figure 4 shows a safety sign displayed on the back of a machine in a workplace.

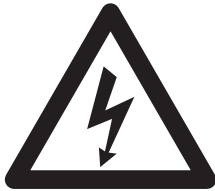

Figure 4

What does the safety sign shown in Figure 4 warn against?

Question 7 (2 marks)

A tool was used to measure the angle X , as shown in Figure 5.

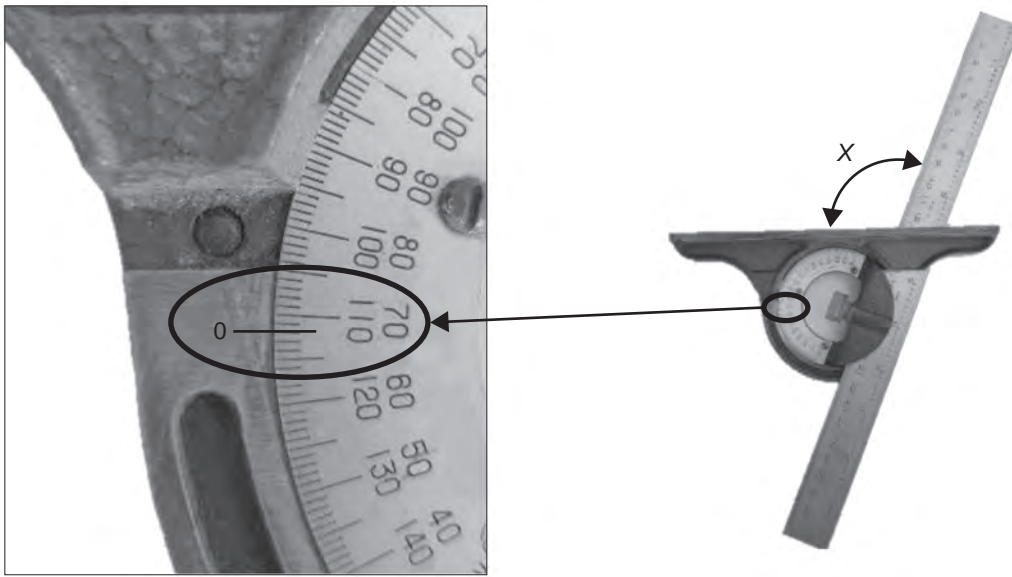

Figure 5





- a. What is the name of the tool shown in Figure 5? 1 mark

- b. What is the size of the angle X ? 1 mark

Question 8 (5 marks)

Five commonly used fasteners are shown in the table below.

Complete the table by naming the specific tool used to attach or tighten each fastener.

Fastener	Specific tool
	
	
	
	
	

DO NOT WRITE IN THIS AREA

TURN OVER

Question 9 (6 marks)

Figure 6 shows a component with three features, A, B and C, that need to be measured and the measuring tool that will be used.

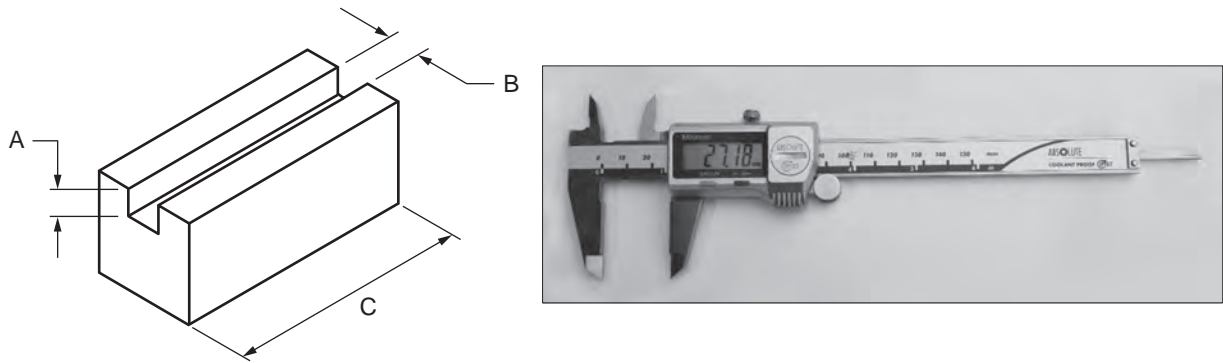

Figure 6

- a. What is the name of the measuring tool shown in Figure 6? 1 mark

- b. List two possible causes of an inaccurate reading when using the measuring tool shown in Figure 6. 2 marks

1. _____

2. _____

DO NOT WRITE IN THIS AREA

- c. i. Draw a circle around the part of the measuring tool that is best suited to measuring feature A, shown in Figure 6a below. 1 mark

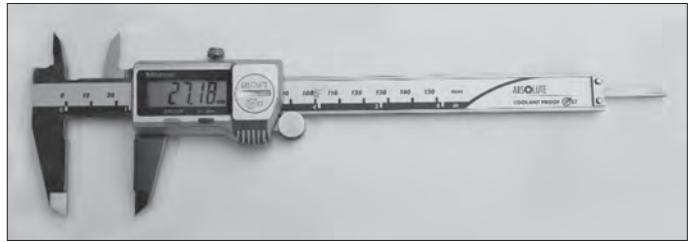
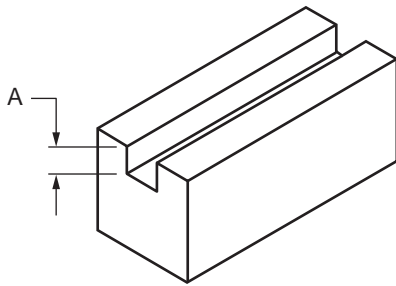

Figure 6a

- ii. Draw a circle around the part of the measuring tool that is best suited to measuring feature B, shown in Figure 6b below. 1 mark

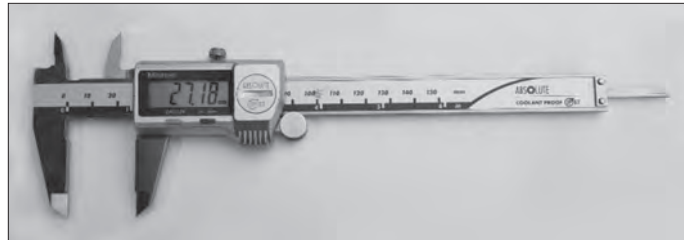
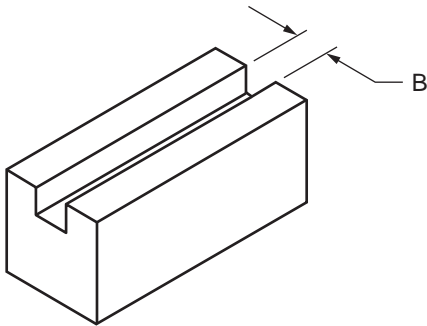

Figure 6b

- iii. Draw a circle around the part of the measuring tool that is best suited to measuring feature C, shown in Figure 6c below. 1 mark

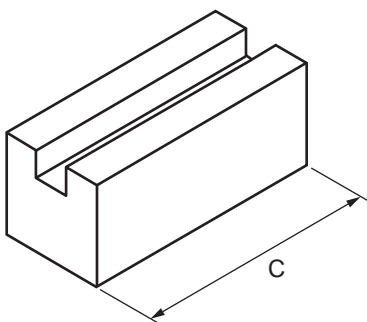

Figure 6c

Question 10 (2 marks)

Figure 7 shows two steel plates, A and B, which will be bolted together using M12 bolts only. No nuts will be used.

Figure 8 shows a tapping chart.

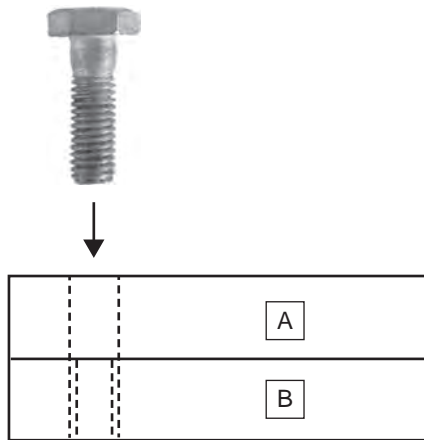

Figure 7

ISO METRIC COARSE THREADS							
NOTE: All dimensions in mm							
O. dia.	Core	Pitch	Depth	Flat	Effec.	Tapp'g drill	Cl'ance drill
1.6	1.1706	0.35	0.2147	0.04375	1.373	1.25	1.65
1.8	1.3706	0.35	0.2147	0.04375	1.573	1.45	1.85
2.0	1.5092	0.40	0.2454	0.05000	1.740	1.60	2.05
2.2	1.6480	0.45	0.2760	0.05625	1.908	1.75	2.25
2.5	1.9480	0.45	0.2760	0.05625	2.208	2.05	2.60
3.0	2.3866	0.50	0.3067	0.06250	2.675	2.50	3.10
3.5	2.7638	0.60	0.3681	0.07500	3.110	2.90	3.60
4.0	3.1412	0.70	0.4294	0.08750	3.545	3.30	4.10
4.5	3.5798	0.75	0.4601	0.09375	4.013	3.80	4.60
5.0	4.0184	0.80	0.4908	0.10000	4.480	4.20	5.10
6.0	4.7732	1.00	0.6134	0.12500	5.350	5.00	6.10
7.0	5.7732	1.00	0.6134	0.12500	6.350	6.00	7.20
8.0	6.4664	1.25	0.7668	0.15625	7.188	6.80	8.20
10.0	8.1596	1.50	0.9202	0.18750	9.026	8.50	10.20
12.0	9.8530	1.75	1.0735	0.21875	10.863	10.20	12.20
14.0	11.5462	2.00	1.2269	0.25000	12.701	12.00	14.25
16.0	13.5462	2.00	1.2269	0.25000	14.701	14.00	16.25
18.0	14.9328	2.50	1.5336	0.31250	16.376	15.50	18.25
20.0	16.9328	2.50	1.5336	0.31250	18.376	17.50	20.25
22.0	18.9328	2.50	1.5336	0.31250	20.376	19.50	22.25
24.0	20.3194	3.00	1.8403	0.37500	22.051	21.00	24.25

Figure 8

Use the tapping chart shown in Figure 8 to answer the following questions.

- a. What size hole should be drilled into plate A? 1 mark

- b. What size hole should be drilled into plate B? 1 mark

Question 11 (2 marks)

A wheelchair access ramp to a platform 500 mm above ground level is to be constructed. The angle of the ramp will be 4° to the horizontal.

Calculate how long the ramp will be in metres. Show your working.

Question 12 (5 marks)

Figure 9 shows an isometric drawing of a machined part.

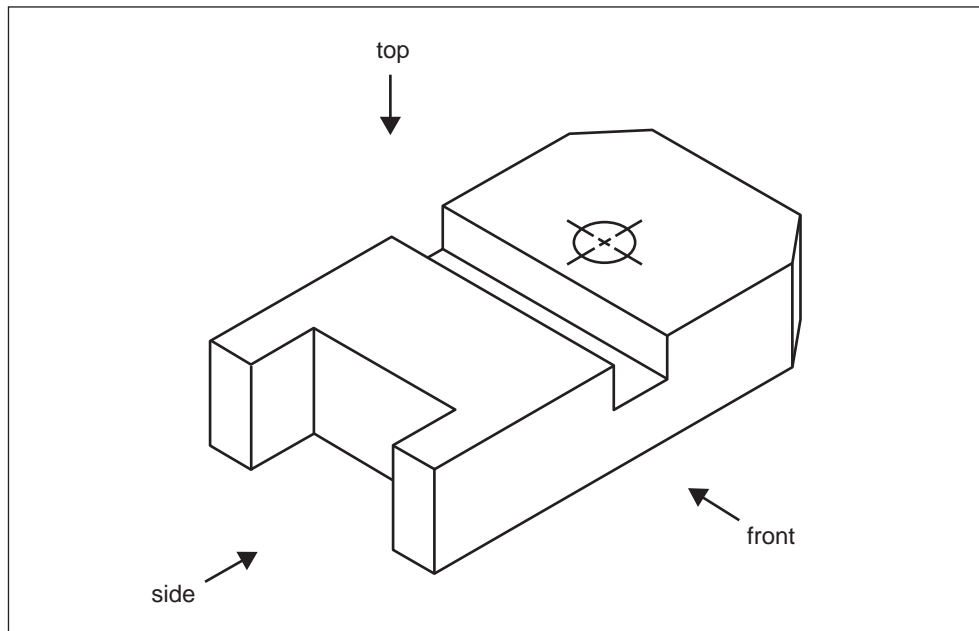
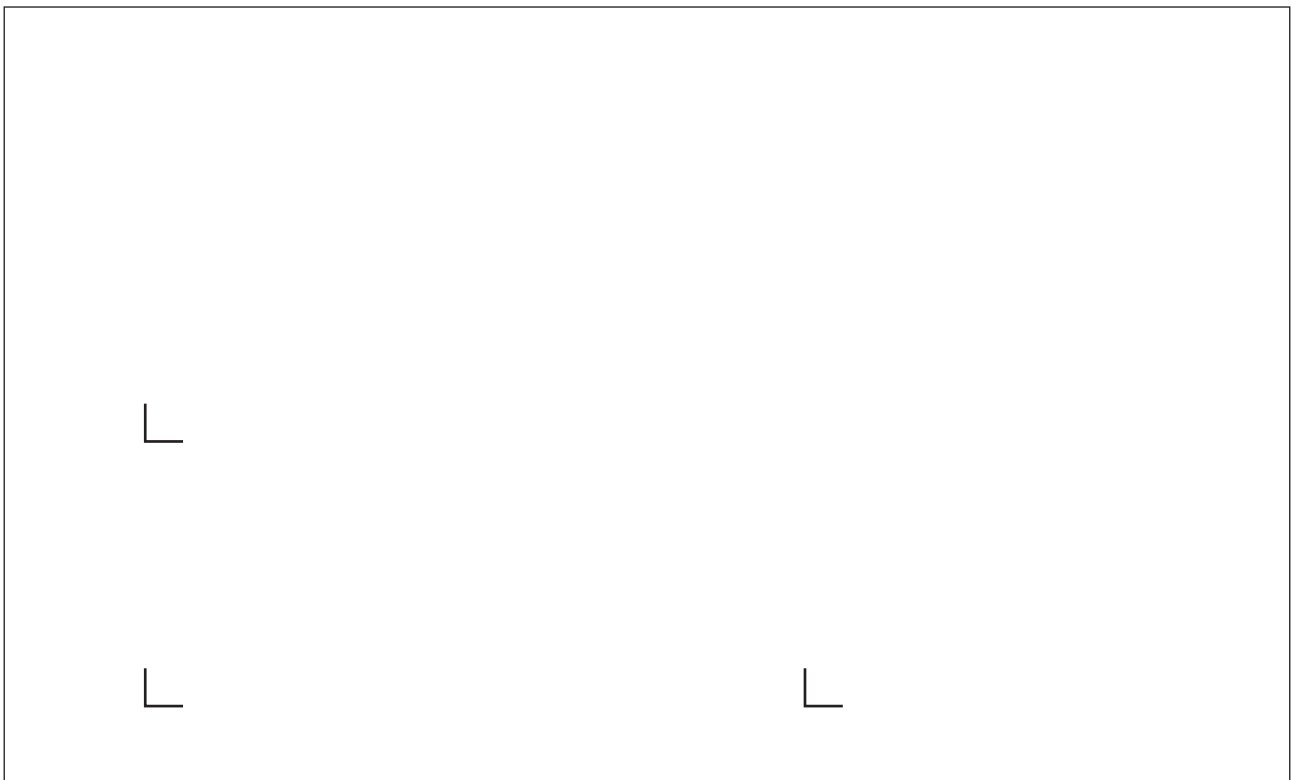

Figure 9

In the space provided below, draw the machined part shown in Figure 9 using third-angle projection. Your drawing should show the following:

- three views (top, side and front)
- all hidden detail
- all centre lines



TURN OVER

Question 13 (10 marks)

Figure 10 shows a shaft that will be made on a lathe from a $\text{Ø} 50$ mild steel bar.

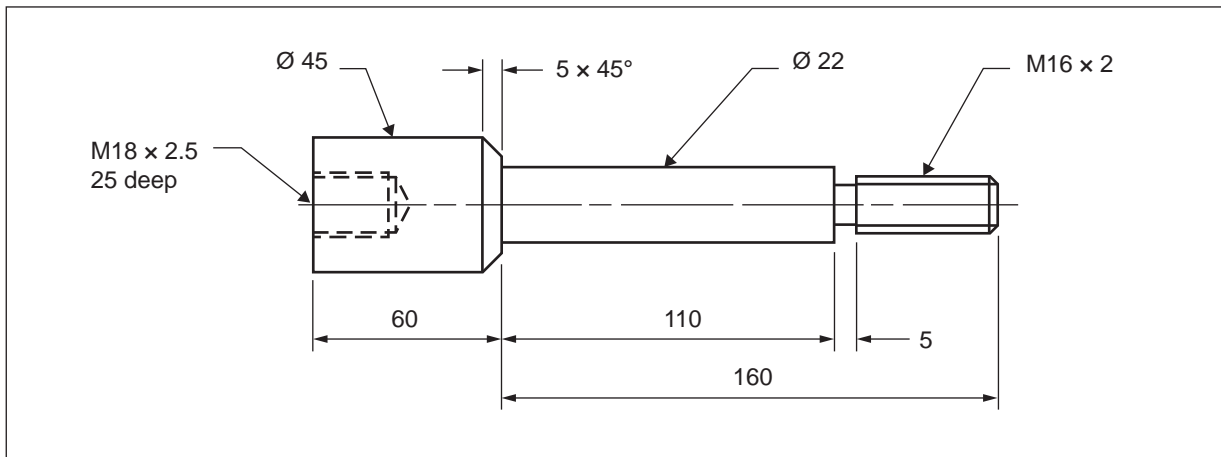

Figure 10

- a. The $\text{Ø} 45 \times 60$ section will be machined first.
 Name the most suitable method to hold the workpiece to machine the $\text{Ø} 45 \times 60$ section. 1 mark

- b. Which other feature of the shaft should be machined using the same set-up when machining the $\text{Ø} 45 \times 60$ section? 1 mark

- c. In the next set-up, the $\text{Ø} 22$ and $\text{M16} \times 2$ thread will be machined.
 - i. Name the lathe accessory that should be used to support the right-hand end of the shaft when machining the $\text{Ø} 22$ and $\text{M16} \times 2$ thread. 1 mark

 - ii. In which part of the lathe will this accessory be held? 1 mark

- d. A cut has just been taken to machine the $\text{Ø} 22$ down to size. The reading on the micrometer is 22.86
 - i. By how much should the cutting tool be advanced for the final cut? 1 mark

 - ii. Which part of the lathe will be used to advance the cutting tool for the final cut? 1 mark

DO NOT WRITE IN THIS AREA

e. Name two methods that can be used to produce the M16 × 2 thread.

2 marks

1. _____

2. _____

f. The $5 \times 45^\circ$ taper needs to be machined.

Describe two methods that can be used to machine short tapers, like the $5 \times 45^\circ$ shown in Figure 10, on a lathe.

2 marks

1. _____

2. _____

Question 14 (2 marks)

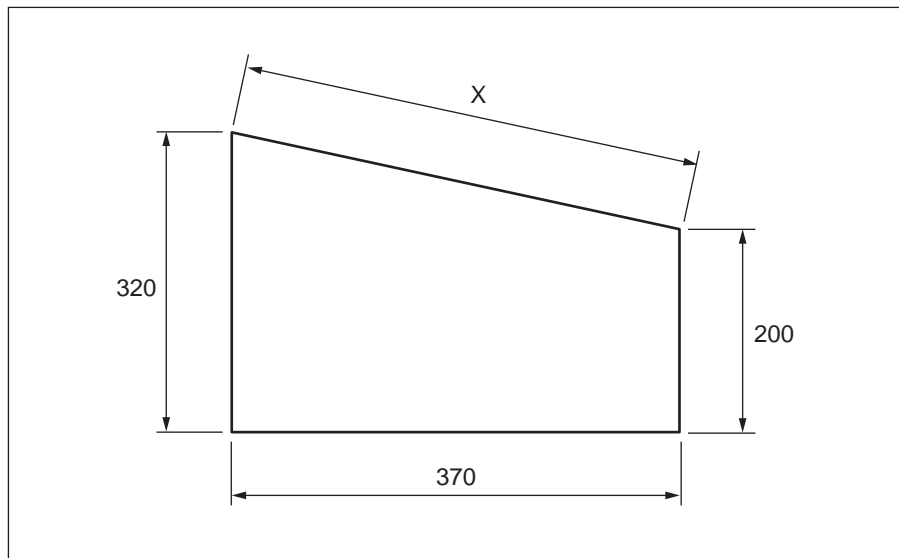

Figure 11

Calculate the length of the side X for the steel plate shown in Figure 11. Show your working.

TURN OVER

Question 15 (4 marks)

Figure 12 shows a part made from 10 mm thick steel plate. The holes have been marked out and are now ready to be produced.

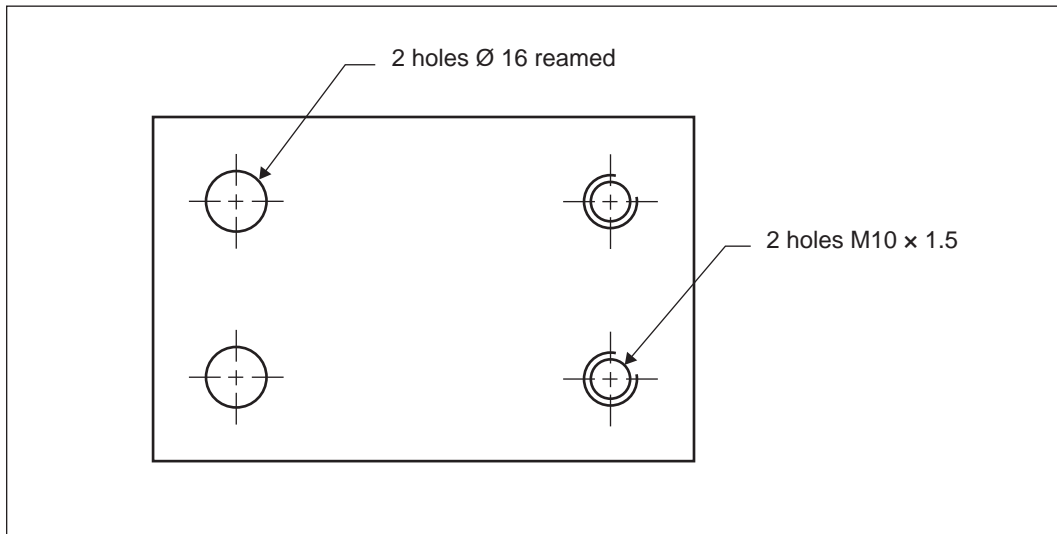

Figure 12



List four tools required to produce all the holes in the steel plate shown in Figure 12.

1. _____
2. _____
3. _____
4. _____

Question 16 (6 marks)

Three common tools used in engineering are shown in the table below.

Complete the table with the correct name for each tool and a common use for that tool.

Tool	Name	Common use
		
		
		

DO NOT WRITE IN THIS AREA

TURN OVER

Question 17 (6 marks)

Figure 13 shows a drawing of a location plate.

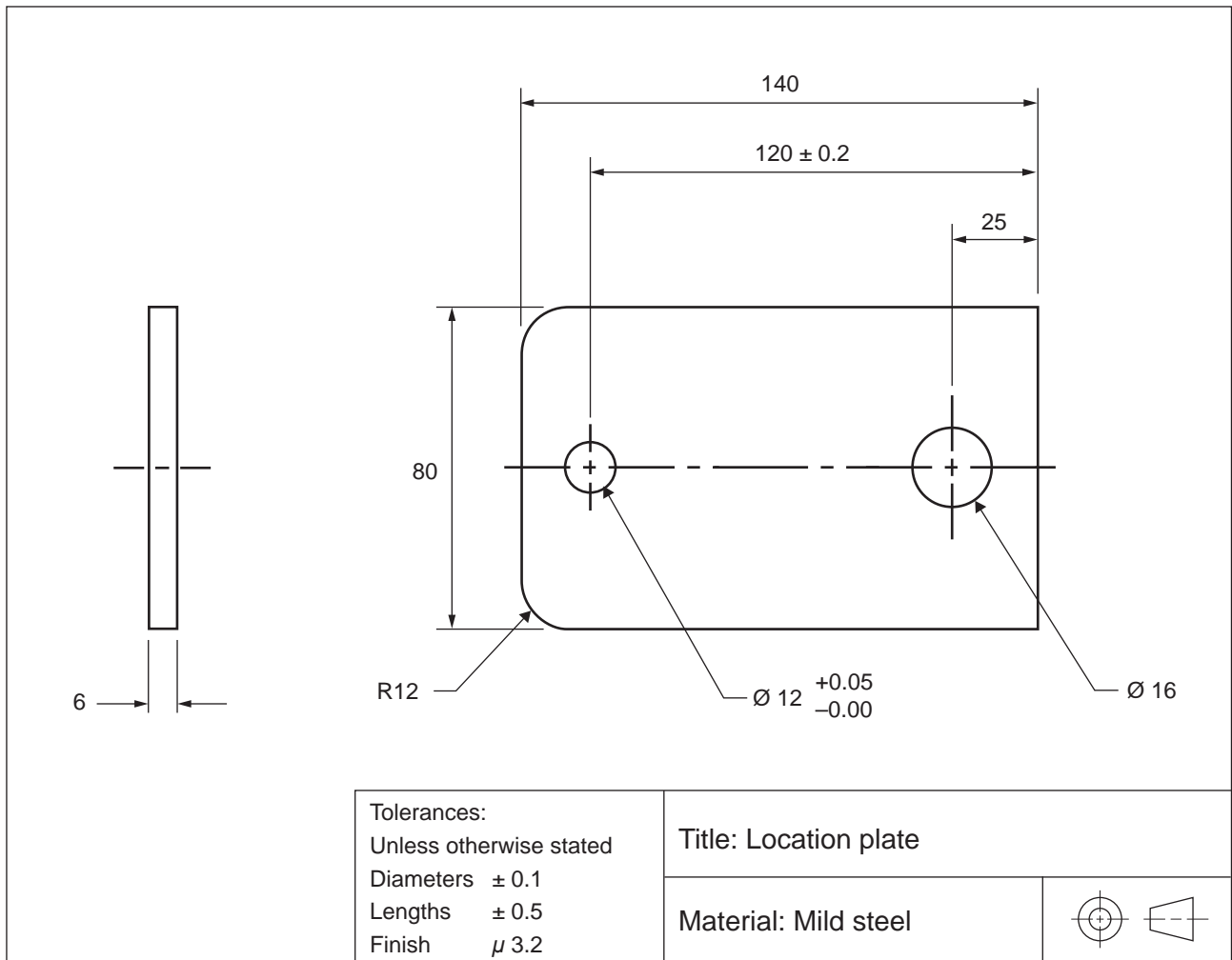

Figure 13

- a. On Figure 13, draw an arrow pointing to the datum edge.
1 mark
- b. State the meaning of the symbol .
1 mark

- c. Complete the table below by listing the maximum and minimum sizes for each dimension of the location plate shown in Figure 13.
4 marks

Dimension	Maximum size	Minimum size
80 mm width		
120 mm length		
Ø 12 hole		
Ø 16 hole		

Question 18 (5 marks)

Figure 14 shows a drawing of a canister and lid made from sheet metal.

The canister has a diameter of 120 mm and a height of 300 mm.

The lid has a diameter of 122 mm and a height of 25 mm.

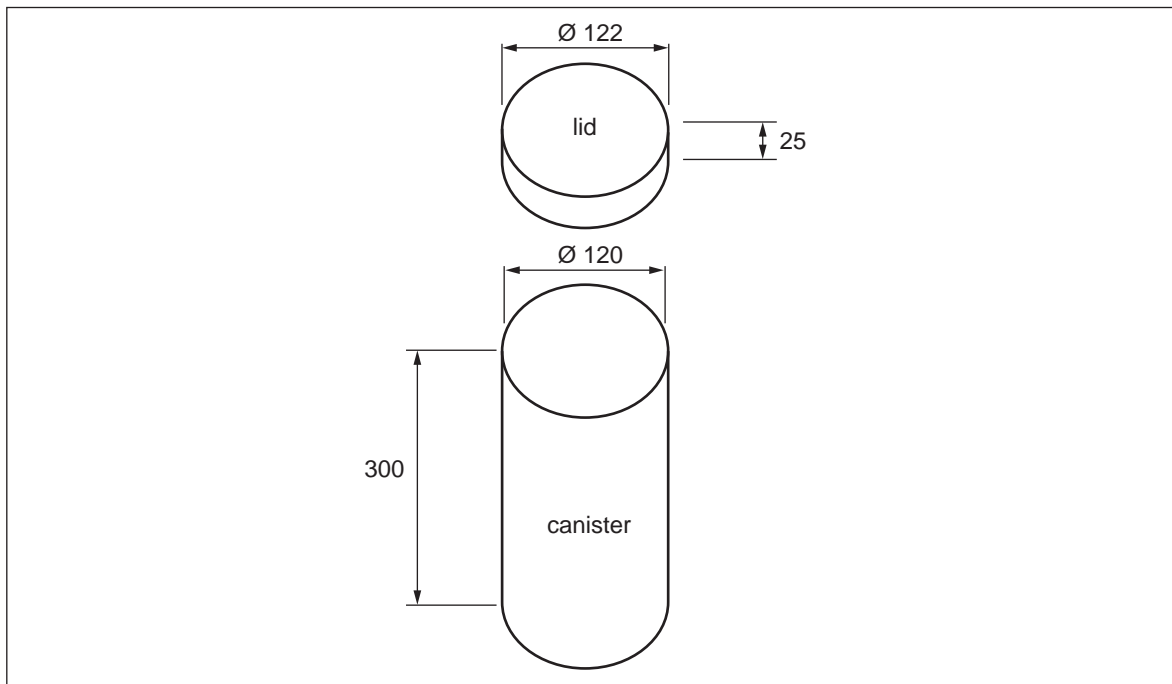

Figure 14

- a. Calculate the circumference, in millimetres, of the lid. Show your working. 2 marks

- b. Calculate the volume, in litres, of the canister. Show your working. 3 marks

$$1 \text{ L} = 1\,000\,000 \text{ mm}^3$$

TURN OVER

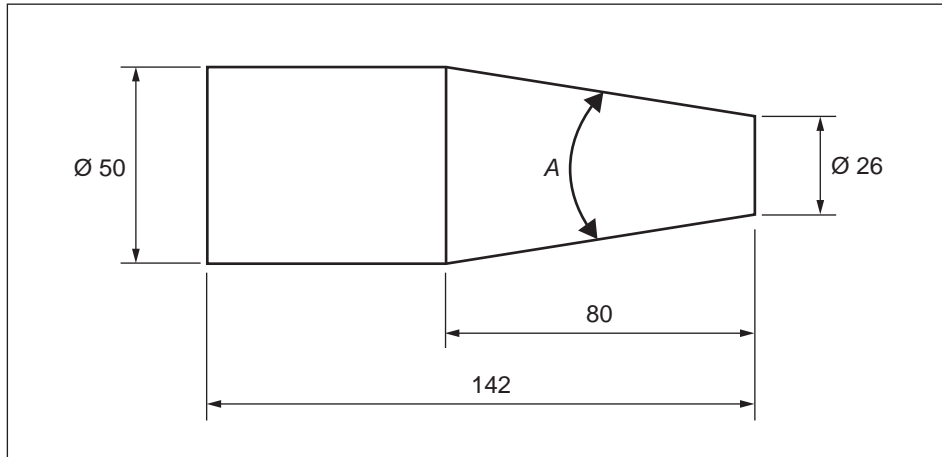
Question 19 (3 marks)**Figure 15**

Calculate the included angle A of the shaft shown in Figure 15. Show your working.

DO NOT WRITE IN THIS AREA

CONTINUES OVER PAGE

TURN OVER

Question 20 (5 marks)

Figure 16 shows an exploded view of a bearing, with components labelled A, B, C, D or E.

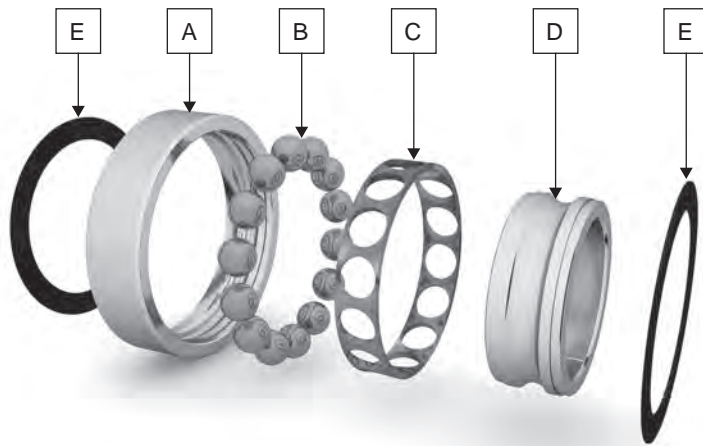

Source: 3DStach/Shutterstock.com

Figure 16

- a. Name the bearing shown in Figure 16. 1 mark

- b. Complete the table below by matching the bearing component with the corresponding letter in Figure 16. 2 marks

Bearing component	Letter
cage	
outer race	
balls	
inner race	

DO NOT WRITE IN THIS AREA

- c. State the type of bearing that would be most suitable for each of the following two applications.

2 marks

rotating seat of an office chair



Source: Aleksandr Kurganov/
Shutterstock.com

wheels of a skateboard



Source: xiaorui/Shutterstock.com

DO NOT WRITE IN THIS AREA

TURN OVER

Question 21 (3 marks)

Figure 17 shows a component that is to be manufactured from a 50 × 15 mild steel bar.

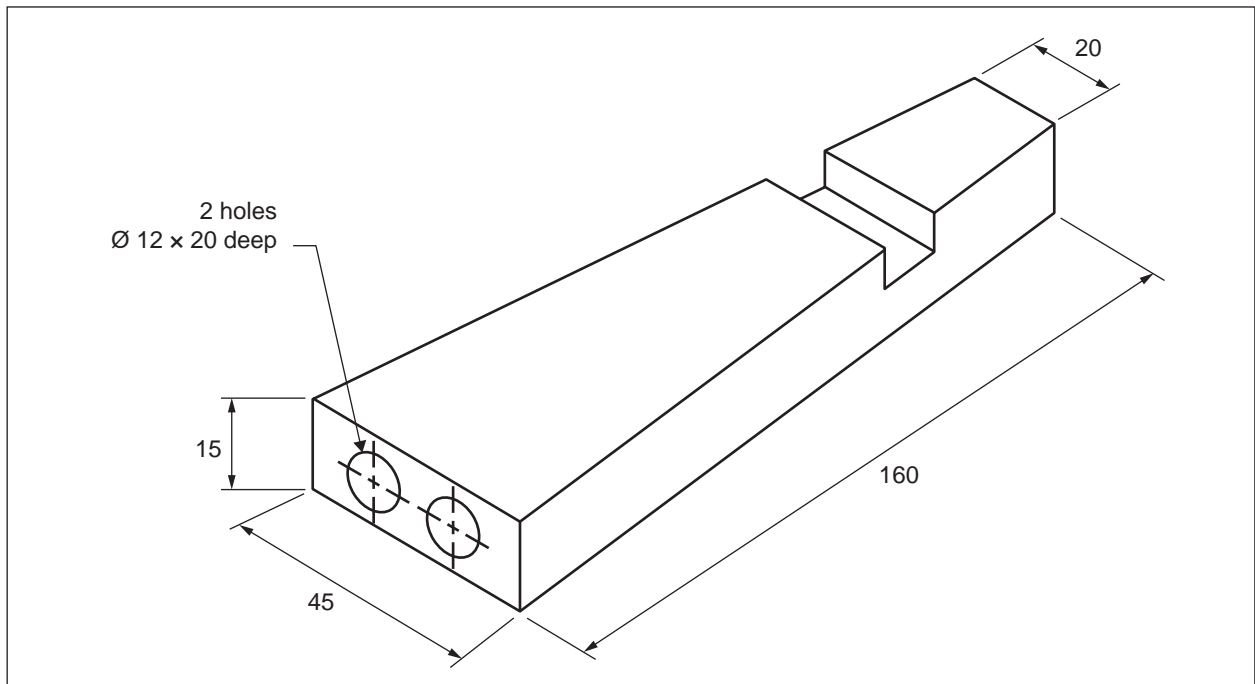

Figure 17

The table below shows the operational steps required to manufacture the component shown in Figure 17. The steps are **not** in the correct sequence.

Complete the table by writing the numbers 2 to 7 next to the correct operational step, with the number 2 indicating the second step in the manufacturing sequence and the number 7 indicating the last step in the manufacturing sequence. The first step has been completed for you.

Operational step	Step no.
Mark out holes.	
Mill slot.	
Cut 163 mm long piece from bar.	1
Mill tapered long sides (both sides).	
Drill holes.	
Square off ends to 160 mm length.	
Centre-punch hole positions.	

DO NOT WRITE IN THIS AREA

Question 22 (2 marks)

Figure 18 shows a metal arch made from a Ø 12 mild steel bar. The top of the arch is a semicircle.

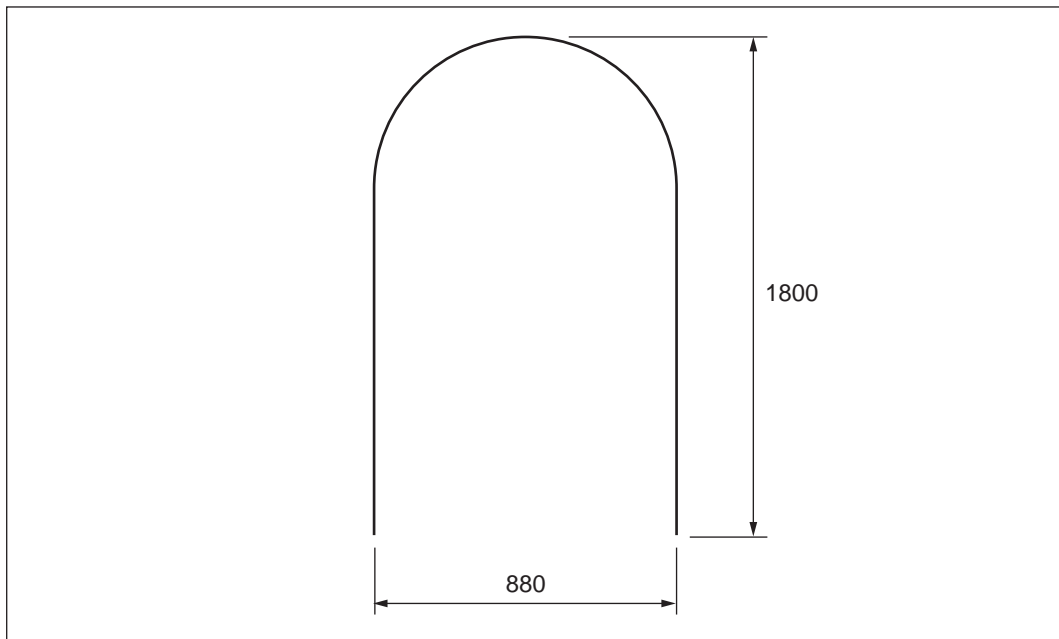

Figure 18

Calculate the length of Ø 12 mild steel bar required to make one metal arch, as shown in Figure 18. Show your working and give your answer correct to the nearest millimetre.

Question 23 (18 marks)

Figure 19 shows a welding table that is being designed for manufacture.

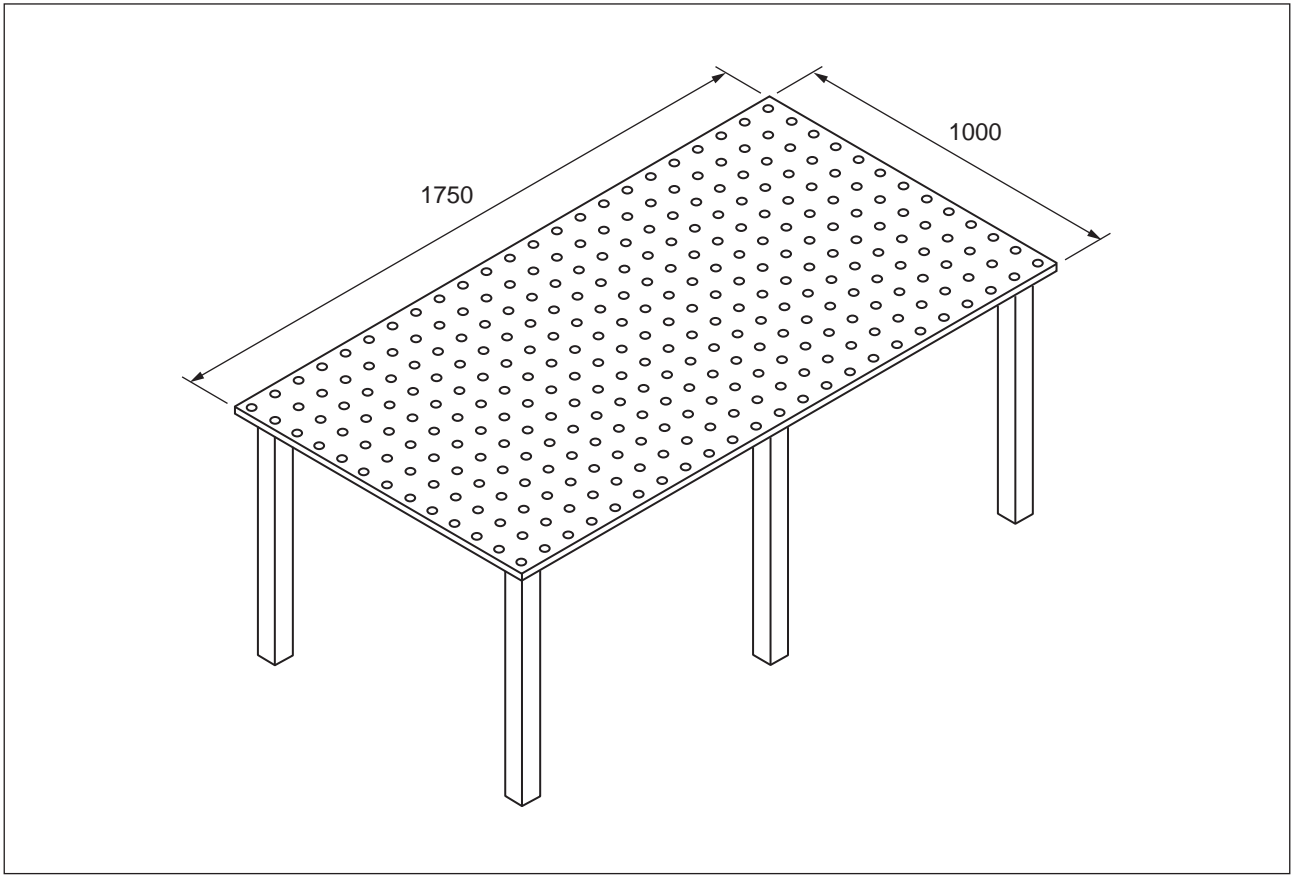

Figure 19

The top of the welding table will be cut from a 16 mm thick steel plate measuring 3000×1800 and weighing 125.6 kg/m^2 .

- a. Calculate the weight of the 3000×1800 steel plate. Show your working. 2 marks

DO NOT WRITE IN THIS AREA

b. To cut it to size, a crane will be used to lift the 3000 × 1800 steel plate onto a plasma machine.

i. Name two lifting accessories that could be used with the crane to lift the steel plate. 2 marks

1. _____

2. _____

ii. Prior to lifting the steel plate, state two things that should be checked on both lifting accessories to ensure the process of lifting the steel plate is safe. 2 marks

1. _____

2. _____

Figure 20 shows the welding table frame, which will be made from 75 mm square hollow section (SHS).

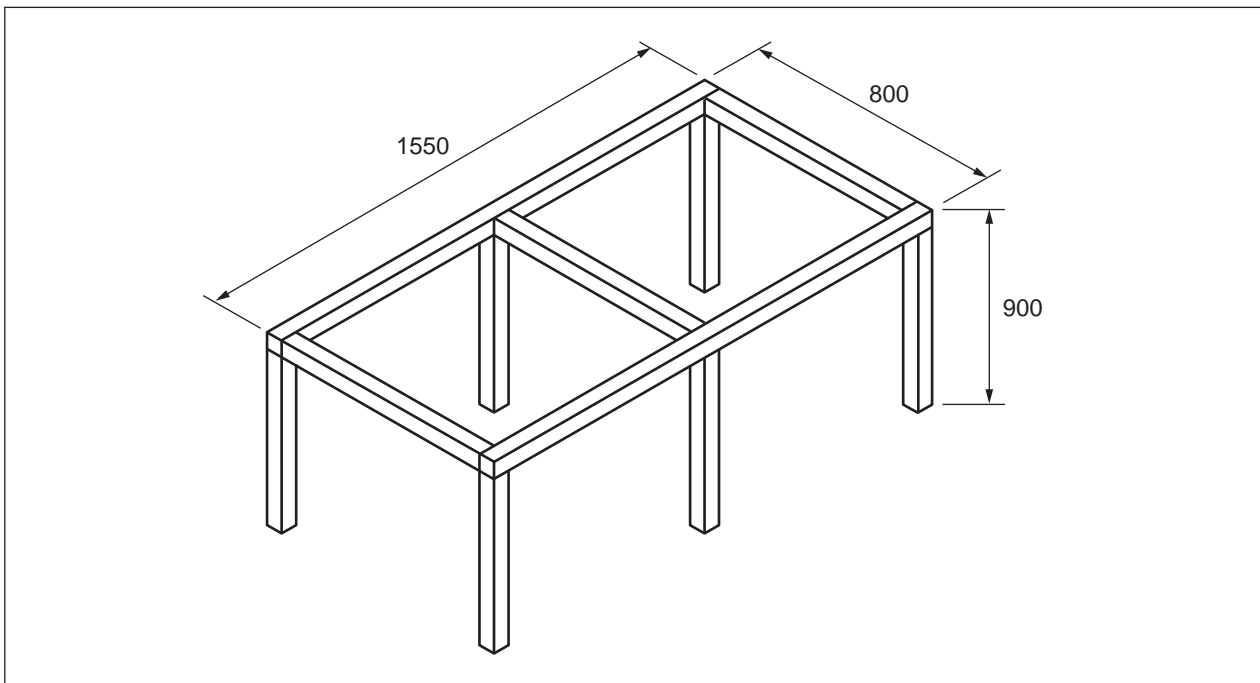

Figure 20

c. Complete the cutting list below to make one welding table frame. 2 marks

Cutting list		
Material	Length	Number of pieces

DO NOT WRITE IN THIS AREA

d. The welding table frame will be tack welded before final welding.

i. Describe tack welding.

1 mark

ii. State the main purpose of tack welding.

1 mark

e. Figure 21 shows the top and frame of the welding table, which need to be joined together.

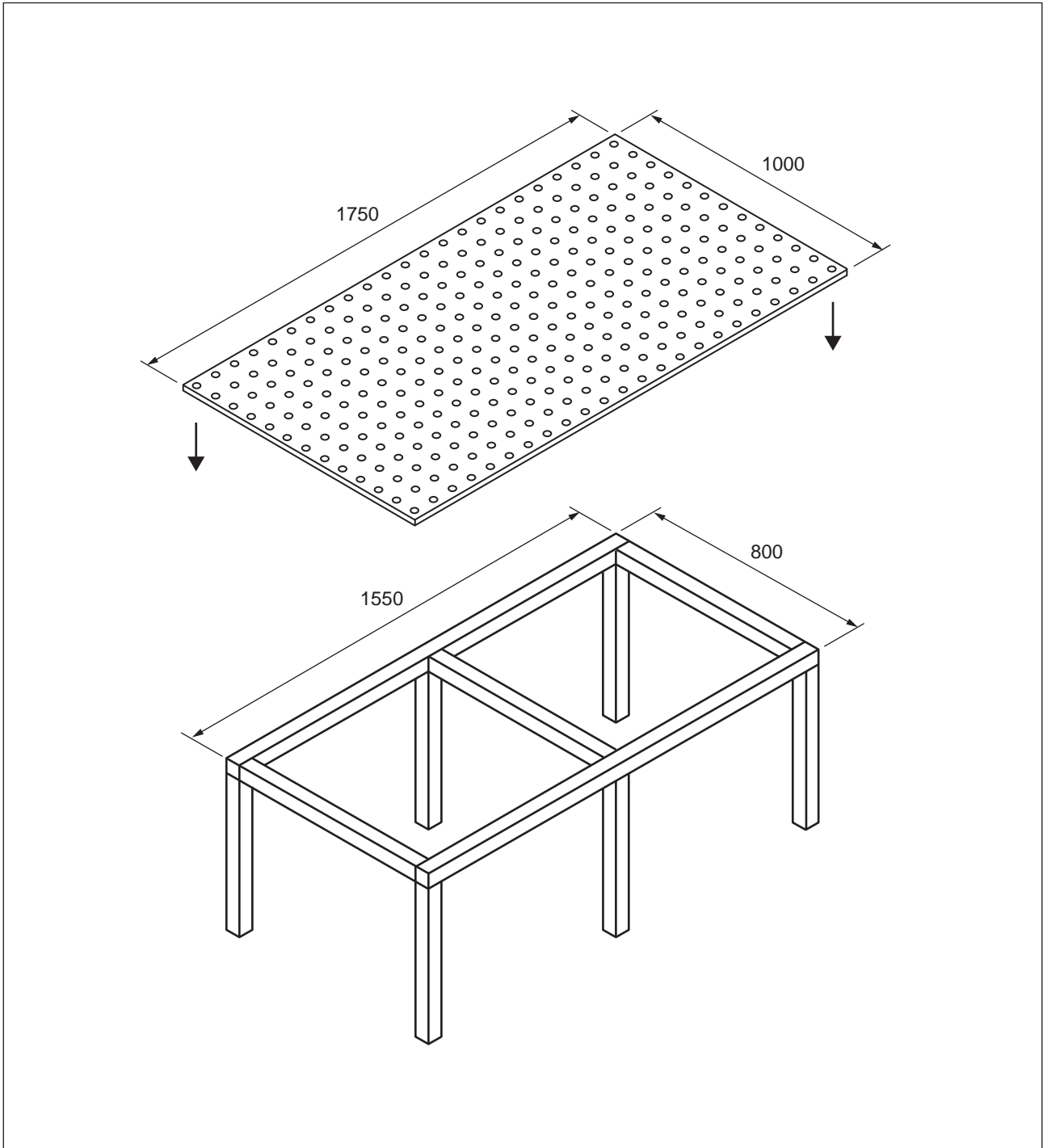

Figure 21

DO NOT WRITE IN THIS AREA

Design a suitable method of joining the top to the frame of the welding table using Figure 22. Your design needs to satisfy the following requirements:

- Allow for the top to be removed for maintenance and replaced when required.
- Provide enough detail for the design to be manufactured, including the materials and parts required.

4 marks

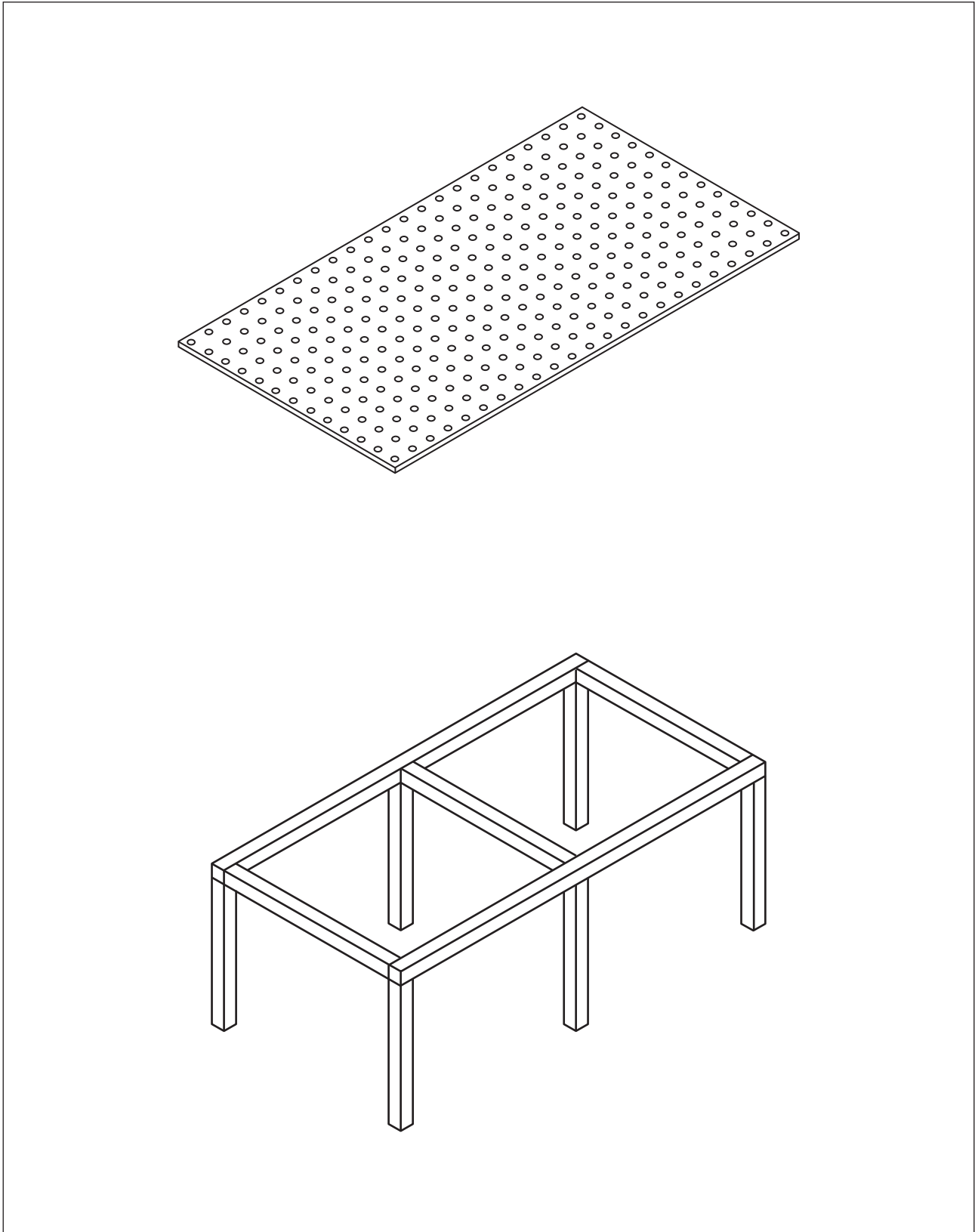

Figure 22

- f. When reviewing the design of the welding table frame, the legs were found to be insufficiently rigid.

On the sketch of the welding table frame shown in Figure 23, design a modification that will make the legs more rigid. Your design must include the following:

- a sketch of your design
- the details of the materials and/or components to be used
- basic dimensions, showing the position of the modification on the frame
- enough detail to allow the modification to be implemented

4 marks

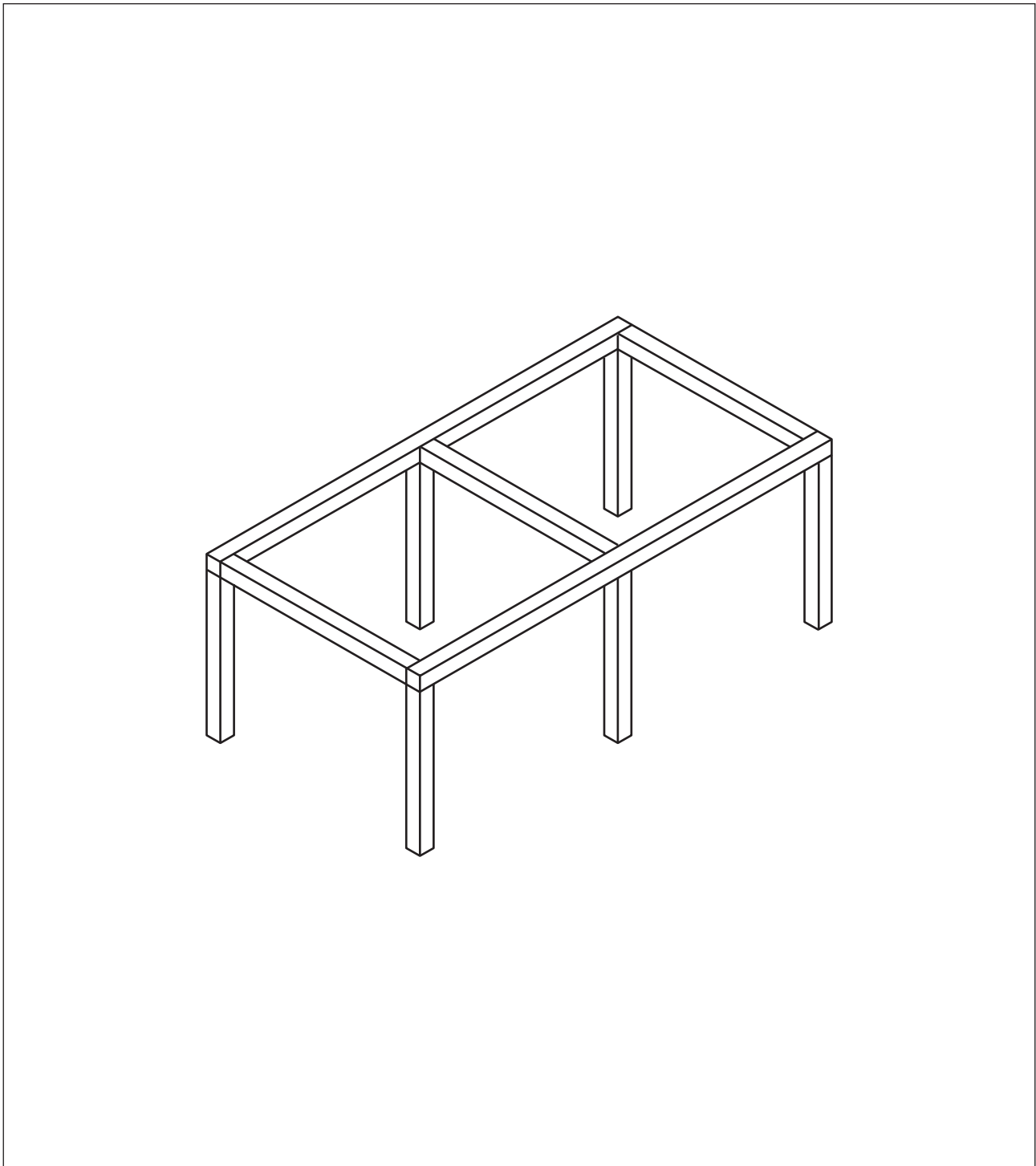

Figure 23