



GENERAL COMMENTS

In 2004, 117 students sat for the VCE VET Furnishing written examination. Questions on the exam were designed to test students' underpinning knowledge of the five modules they had studied in Units 3 and 4.

SPECIFIC INFORMATION

Section A – Multiple-choice questions

This table indicates the number of students who chose each option. The correct answer is indicated by shading.

Question	A %	B %	C %	D %	No Answer %
1	32	9	54	5	0
2	5	9	3	83	0
3	56	5	14	25	0
4	55	30	4	10	1
5	69	5	9	17	0
6	3	28	44	24	1
7	76	3	8	13	0
8	2	12	82	4	0
9	15	11	11	63	0
10	51	11	32	6	0
11	9	85	3	3	0
12	16	23	39	21	1
13	58	6	26	10	0
14	16	3	21	60	0
15	12	7	61	21	0
16	28	53	13	6	0
17	18	18	27	37	0
18	38	27	26	6	2
19	1	1	2	97	0
20	24	30	21	26	0

Section B – Short answer questions

Question 1

Name two decorative treatments that can be applied to drawer fronts.

Marks	0	1	2	Average
%	23	27	50	1.3

Acceptable answers included:

- small bead to give a framed appearance
- raised or decorative panel
- cocked beading
- applied wood carving
- routed moulded edge
- decorative veneered front
- stringing or inlay veneers.

One mark was given for each treatment named correctly. Hardware of any kind, for example brass handles, was not accepted.

2004 Assessment Report



Question 2

Name and draw two different joints used in timber door frame construction. Describe one advantage and one disadvantage of each joint.

Joint 1

Marks	0	1	2	3	4	Average
%	21	5	13	36	25	2.4

Joint 2

Marks	0	1	2	3	4	Average
%	33	5	11	30	20	2.0

Examples accepted included:

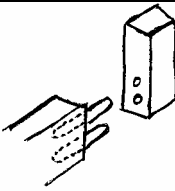
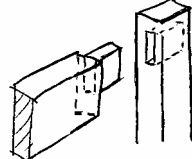
Name and sketch	Advantage	Disadvantage
 Dowel joint	Simple to make, fairly strong compared with other joints, can help to strengthen a scribed moulded or double rebated joint, joint can be rebated after assembly, stronger than a biscuit joint.	Difficult to carry a heavy glass panel, not as strong as more traditional mortise and tenon joints.
 Mortise and tenon joint	Very strong joint, traditionally used for door frame construction, can be easily grooved for panel insertion prior to assembly, allows for through or haunched types to be used further improving strength and aesthetic factors.	Higher labour and machine costs involved, need to be accurate to gain maximum strength.

Other acceptable joints included a dowelled mitre joint and a mitred biscuit joint.

Students received one mark for each relevant joint named, one mark for a correct accompanying sketch, one mark for each legitimate advantage and one mark for each legitimate disadvantage. A total of eight marks for parts i. and ii. were available.

Question 3

Name and draw either a 'lay on' or an 'inset' door. Show the placement of the butt hinges in your drawing.

Marks	0	1	2	Average
%	33	31	36	1.0

Type of door: Inset

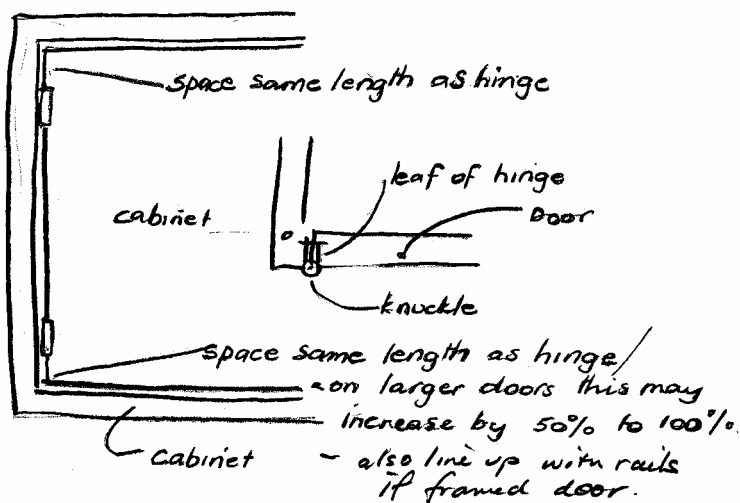

Students received one mark for a correct drawing of the door type used and one mark for correctly showing the position of the door hinges in relation to the door type.

2004 Assessment Report



Question 4

Name the moulding in each of the following diagrams.

Marks	0	1	2	Average
%	62	15	24	0.6

One mark was awarded to students for each moulding sketch successfully labelled.

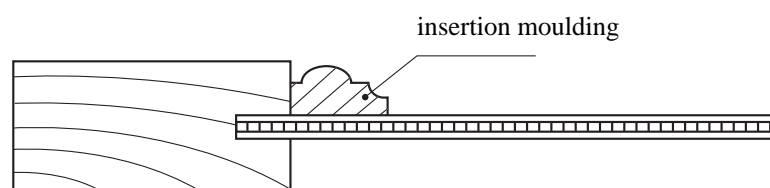
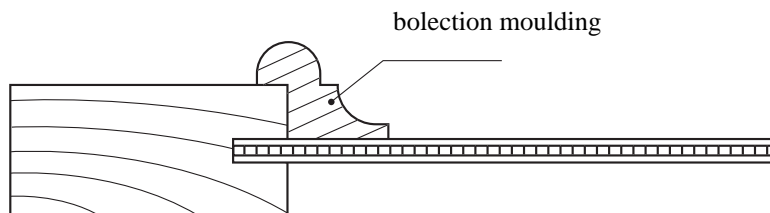

Question 5

The diagram below shows the third drawer of a nest of five.

a. Label each of the four drawer components indicated on the diagram above.

Marks	0	1	2	3	4	Average
%	16	21	33	22	9	1.9

- drawer slip
- drawer back
- muntin
- drawer bottom.

Students were awarded one mark for each drawer named correctly (see part b for answers).

b. Using the industry-accepted method, correctly mark the drawer front and right-hand drawer side on the diagram above.

Marks	0	1	2	Average
%	90	8	3	0.2

Students were awarded one mark for each mark (quadrant) drawn correctly onto the diagram.

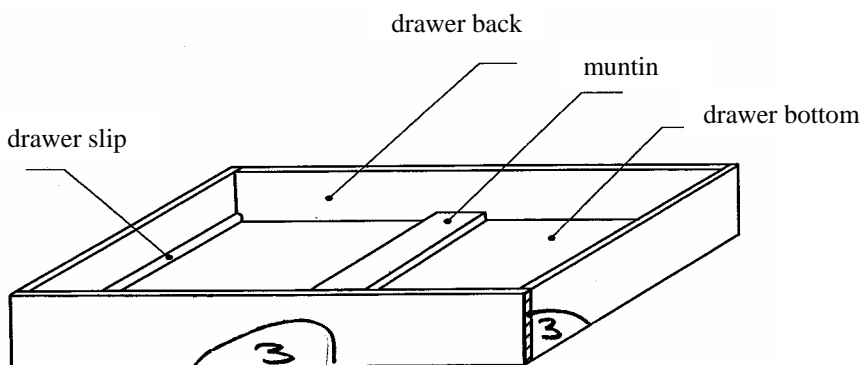

2004 Assessment Report



Question 6

What four things do quadrant marks tell us?

Marks	0	1	2	3	4	Average
%	55	28	12	3	2	0.7

Accepted answers included:

- which drawer side, left or right
- which number drawer in the set
- indicates front and back (top and bottom)
- indicates outside surfaces
- best faces, i.e. grain matching
- selection of grain direction (sides in particular).

One mark (up to a total of four) was awarded for each correct response.

Question 7

In the table below, tick the four correct methods of joining drawer sides to drawer fronts.

Marks	0	1	2	3	4	Average
%	2	0	0	53	45	3.4

All but 'through dovetail' were given marks. Better responses were tongue and trench, slot dovetail, stopped housing and lapped dovetail.

Question 8

You are making two timber door frames for a sideboard. The door frames will be constructed using bridle joints.

a. Using the information in the diagram above, work out the finished length of the rails. You should allow for gaps when calculating your response.

Marks	0	1	Average
%	99	1	0.0

381 – 382mm

b. What is the industry-accepted gap between doors?

Marks	0	1	Average
%	63	37	0.4

1 – 2mm (not 2mm only)

c. What is the overall width of the finished and fitted door?

Marks	0	1	Average
%	91	9	0.1

380 – 380.5mm

Question 9

Complete the cutting list on page 11 for unit one of the modular entertainment unit. Your cutting list should be generated from the front elevation (Figure A) and section drawings (Figure B) from the insert.

Marks	0	1	2	3	4	5	6	7	8	9	10	11	12	Average
%	7	1	2	1	5	9	7	14	16	20	11	4	4	7.1



Cutting list for unit 1						
Part	No. of pieces	Length	Width	Thickness	Material	Remarks
end	2	1800	295	18	antique white	13 x 3 rebate for ply
top	1	414	295	18	antique white	13 x 3 rebate for ply
bottom	1	414	295	18	antique white	13 x 3 rebate for ply
fixed shelf	1	414	292	18	antique white	
adjustable shelf	3	412	282	18	antique white	
drawer front	2	414	150	18	antique white	
drawer front	1	412/414	200	18	antique white	
base rail	1	414	75	18	antique white	
drawer side	4	250	114	16	white melamine	
drawer front	2	357	114	16	white melamine	
drawer back	2	357	114	16	white melamine	
drawer side	2	250	162	16	white melamine	
drawer front	1	357	162	16	white melamine	
drawer back	1	357	162	16	white melamine	
drawer bottom	3	389	250	16	white melamine	
unit back	1	1790	440	3	antique white ply	

One mark was awarded for each item correctly entered, up to a total of twelve for the question.

Question 10

Using the grid provided below, draft a sheet cutting plan for all of the 18 mm antique white melamine board required to complete unit 3 of the modular entertainment unit shown in Figure A and Figure B.

Marks	0	1	2	3	4	5	Average
%	39	14	14	17	10	6	1.6

The plan should have shown the most economical way to cut a standard 2400 x 1200mm sheet and each of the parts set out should have been labelled.

Many students incorrectly selected Unit 1 instead of Unit 3.

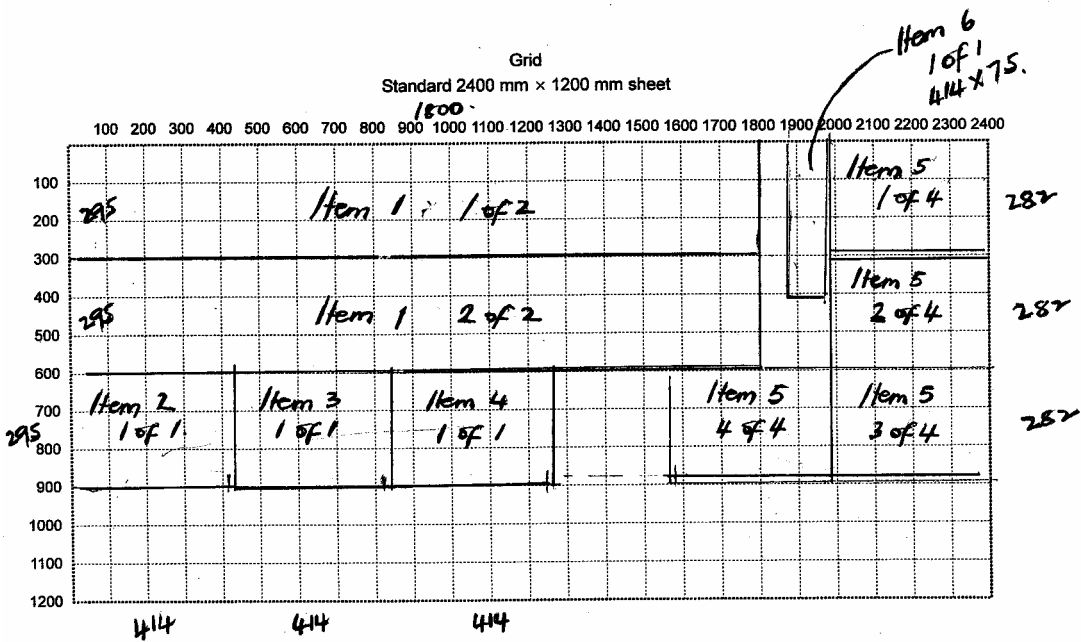

Question 11

Use the correct terms from the list below to label six of the eight parts of the modular entertainment unit indicated.

Marks	0	1	2	3	4	5	6	Average
%	3	0	1	3	6	18	70	5.5

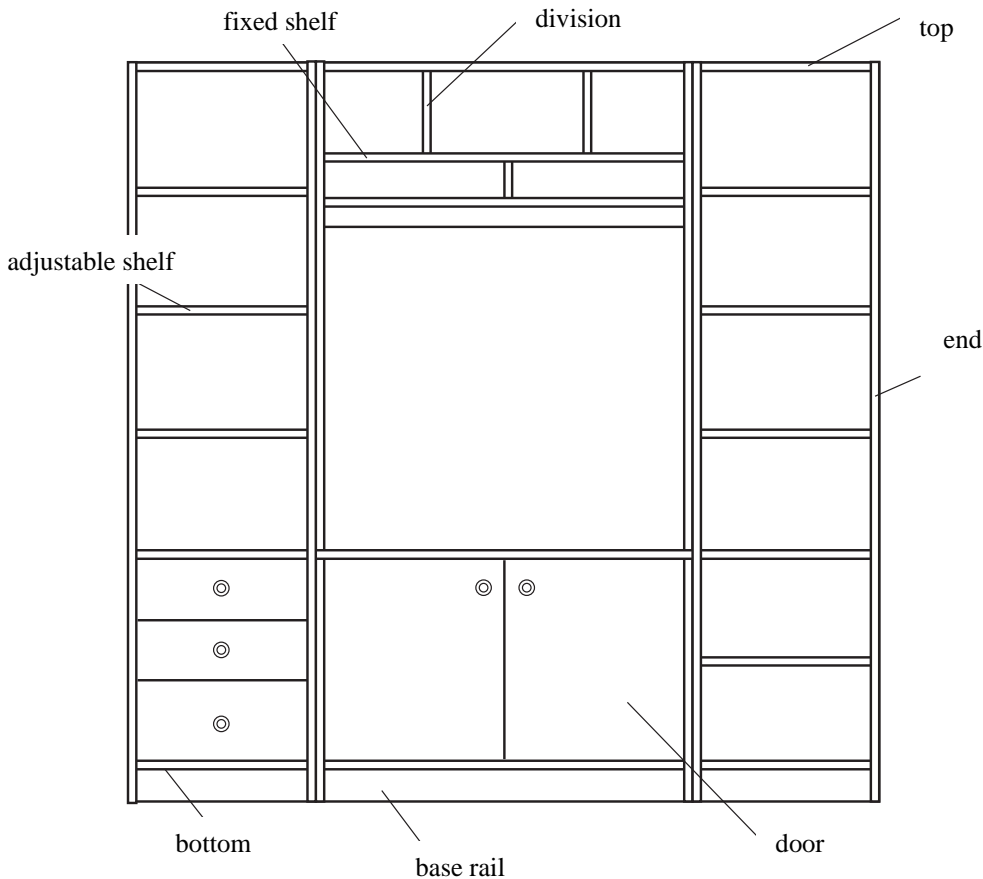

One mark was awarded for each correct response, a total of six marks for the question.

2004 Assessment Report



Question 12

List four items of hardware that would be included in the construction and finishing of a modular entertainment unit.

Marks	0	1	2	3	4	Average
%	33	9	14	18	26	2.0

Responses that were awarded marks included:

- door knobs/handles
- concealed hinges
- mechanical drawer runners
- adjustable shelf supports
- pins and dowels.

Question 13

What is the difference between quality control and quality systems?

Marks	0	1	2	Average
%	37	43	20	0.9

Quality control is the process of inspecting and checking and making sure each step of the process (system) is up to the standard required. Quality systems are the procedures of manufacturing and incorporating 'quality control'.

Responses along the lines of those above were awarded marks.

Section C – Case study

Question 1

a. Sketch a traditional style cabinet with two drawers and a door to meet the customer's requirements.

Marks	0	1	2	3	Average
%	13	17	35	36	2.0

b. Use labelled pointers on your sketch to identify three features that match the customer's display cabinet.

Marks	0	1	2	3	Average
%	29	16	23	32	1.6

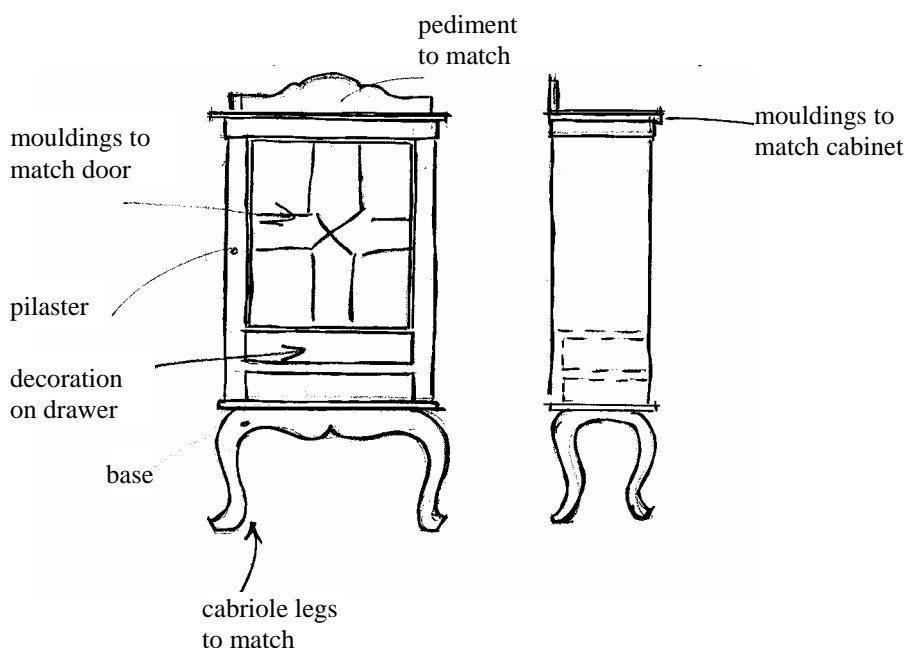



Question 2

In the construction of the new cabinet, it is important to make sure that when cramping up end and door frames, twist or wind does not occur. Explain why.

Marks	0	1	2	Average
%	26	44	30	1.1

Two marks were awarded for a response similar to the following statement: 'If frames are twisted the assembled job will be twisted, which makes fitting doors and drawers to a carcass very difficult and looks bad visually'.

Question 3

Identify six technical terms from the list below which are relevant to construction of the end and door frames of the new cabinet. Write the name of each in the space provided.

Marks	0	1	2	3	4	5	6	Average
%	6	1	1	7	19	45	21	4.5

- horns
- panel
- rail
- stile
- bolection mould
- beading.

Question 4

The beadings in the door of the customer's display cabinet (Figure C) divide or separate the glass inside the door frame.

Complete the sketch below to indicate one way that the glass would be held in place.

Marks	0	1	Average
%	36	64	0.7

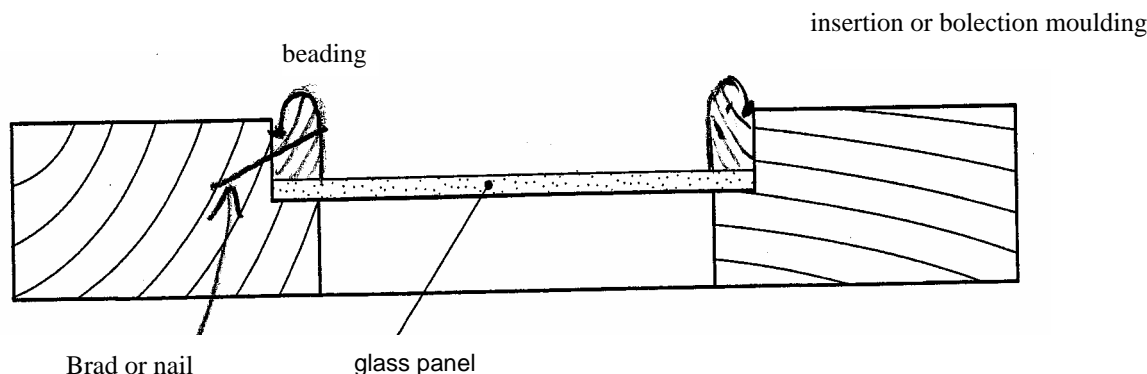

Question 5

List three items, tools or equipment needed to correctly assemble end and door frames.

Marks	0	1	2	3	Average
%	15	14	34	37	1.9

Correct items/tools/equipment included:

- sash cramps
- squaring stick or rod
- PVA glue
- cramping blocks
- dowels
- glue brush
- a straight edge
- large try square.

2004 Assessment Report



Question 6

The cabinet-maker has a checklist of standard quality indicators that is used to ensure all completed work meets quality requirements.

Which four indicators should the cabinet-maker use to check the quality of the completed traditional style cabinet?

Marks	0	1	2	3	4	Average
%	8	3	19	51	20	2.8

The four correct answers were:

- door and drawer clearances are even
- all arrises are removed
- surface machine marks are removed
- no visible scratches, dents or blemishes are present.

One mark (up to a total of four) was awarded per quality indicator.

Question 7

When constructing the customer's new cabinet, the cabinet-maker needs to use hardware suitable for the situation.

List two hardware fittings that are suitable for the construction of the new cabinet and complete the table below.

Fitting 1

Marks	0	1	2	3	4	Average
%	57	4	9	17	14	1.3

Fitting 2

Marks	0	1	2	3	4	Average
%	58	3	11	16	12	1.2

Typical responses included:

Suitable hardware to be used in the construction of the customer's new cabinet	Where on the new cabinet would this hardware be used?	Why is this hardware the most suitable? Give two reasons.
Brass butt hinges	<ul style="list-style-type: none"> • to hang/hinge the door • hanging stile in line with top and bottom rail 	<ul style="list-style-type: none"> • looks smart and traditional • does not distract from appearance
Cut cupboard lock	<ul style="list-style-type: none"> • to keep door and drawers closed and locked • centre top of drawers and above centre of locking stile on door 	<ul style="list-style-type: none"> • traditionally used for this application • can be keyed alike

One mark was awarded for each suitable fitting, one mark for where the hardware would be used, and two marks for why the hardware is most suitable. Full marks were awarded for two ideas as to why the hardware was suitable. A total of eight marks were available for the question.