

STUDENT NUMBER Letter

VISUAL COMMUNICATION DESIGN

Written examination

Monday 8 November 2021

Reading time: 9.00 am to 9.15 am (15 minutes)

Writing time: 9.15 am to 10.45 am (1 hour 30 minutes)

QUESTION AND ANSWER BOOK

Structure of book

<i>Number of questions</i>	<i>Number of questions to be answered</i>	<i>Number of marks</i>
11	11	90

- Students are permitted to bring into the examination room: pens, lead and coloured pencils, fineliners, highlighters, erasers, sharpeners, rulers, set squares, protractors, compasses, and circle and ellipse templates.
- Students are NOT permitted to bring into the examination room: markers, tee-squares and boards, texture boards, blank sheets of paper and/or correction fluid/tape.
- No calculator is allowed in this examination.

Materials supplied

- Question and answer book of 22 pages
- Resource book of 14 pages

Instructions

- Write your **student number** in the space provided above on this page.
- All written responses must be in English.

At the end of the examination

- You may keep the resource book.

Students are NOT permitted to bring mobile phones and/or any other unauthorised electronic devices into the examination room.

Instructions

Answer **all** questions in the spaces provided.

Question 1 (4 marks)

Refer to page 3 of the resource book for larger colour versions of the visual communications that are related to Question 1.

Tick (✓) the correct response for each image.



Figure 1

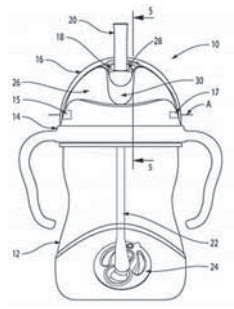

Figure 2



a. Identify the dominant typographic convention. 1 mark

- serif
- leading
- kerning
- sans serif

b. Identify the intellectual property that best protects the designs. 1 mark

- patent
- trademark
- trade secret
- explanatory drawing

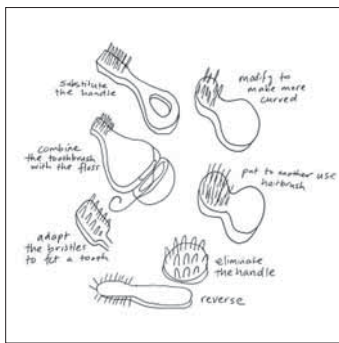

Figure 3



Figure 4

c. Identify the correct design thinking technique. 1 mark

- critical thinking
- creative thinking
- reflective thinking
- investigative thinking

d. Identify the dominant method. 1 mark

- paper
- typography
- photography
- digital-based methods

DO NOT WRITE IN THIS AREA

Question 2 (7 marks)

Refer to page 4 of the resource book for larger colour versions of the visual communications that are related to Question 2.



Figure 5

Marcus Lee, a proud Aboriginal descendant of the Karajarri people, created the original artwork used in the *Reconciliation Action Plan July 2019 – July 2021* by the Reece Group. Figure 5 shows the front cover and a double-page spread from the booklet.

- a. What is the purpose of the visual communication shown in Figure 5? 1 mark

- b. Using evidence from Figure 5, identify **one** design element and discuss how this design element has been used effectively with the design principle of figure-ground. 3 marks

- c. With reference to Figure 5, discuss how the design principle of cropping has been used effectively in the layout of the design of the pages shown. 3 marks

Question 3 (5 marks)

Refer to pages 5 and 6 of the resource book for larger colour versions of the visual communications that are related to Question 3.



Figure 6



Figure 7

- a. The new Shepparton Art Museum building, shown in Figure 7, looks significantly different from the old building, shown in Figure 6.

Using evidence from Figure 6 and Figure 7, discuss **one** design constraint other than materials that might have been included in the brief for the design of the new building.

3 marks

DO NOT WRITE IN THIS AREA



Figure 8

- b. Identify a material used to produce the exterior of the new Shepparton Art Museum building, shown in Figure 8. With reference to aesthetic factors, explain why the designer might have selected this material.

2 marks

DO NOT WRITE IN THIS AREA

TURN OVER

Question 4 (9 marks)

Refer to page 7 of the resource book for larger colour versions of the visual communications that are related to Question 4.



Figure 9

Figure 9 shows the Shepparton Art Museum logo and some architectural features of the new building. The marketing department of the museum requires you to design a souvenir key ring to represent the new building.

In the template provided on page 7, create a two-dimensional design for Side A of the key ring. Your design must refer to the architectural features shown in Figure 9.

Your design must:

- use shape and cropping
- use only black, white and grey
- provide a recognisable link to the new building
- include the type **sam.**

In the template provided on page 7, create a three-dimensional design for Side B of the key ring. Your design must refer to the architectural features shown in Figure 9.

Your design must:

- use line and cropping
- use only black, white and grey
- provide a recognisable link to the new building.

Side A

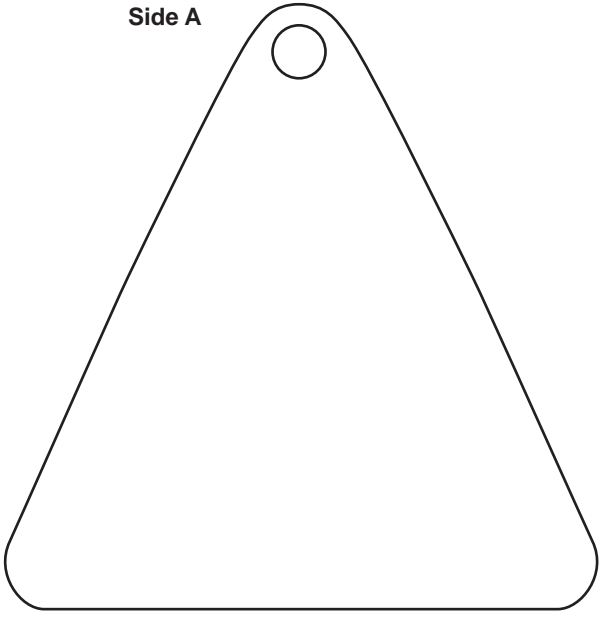

Side B

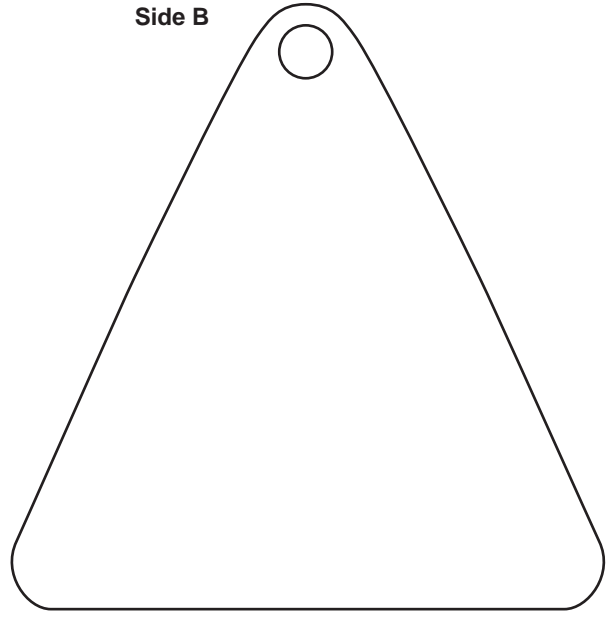

DO NOT WRITE IN THIS AREA

TURN OVER

Question 5 (5 marks)

Refer to page 8 of the resource book for larger colour versions of the visual communications that are related to Question 5.



Figure 10

Melbourne designer, illustrator and creative director Laura Blythman is well known for creating colourful designs that have attracted a range of clients and brands.

- a. Figure 10 shows one of Laura Blythman’s designs.

With reference to Figure 10, describe **two** methods that the designer might have explored during the development of concepts stage of the design process.

3 marks

DO NOT WRITE IN THIS AREA



Figure 11

- b.** Figure 11 shows some of Laura Blythman's fabric designs being used in a range of shoes.

Describe **two** decisions that the designer of the shoes has made so that the design of the shoe complements the design of the chosen fabric.

2 marks

Question 6 (7 marks)

Refer to page 9 of the resource book for larger colour versions of the visual communications that are related to Question 6.

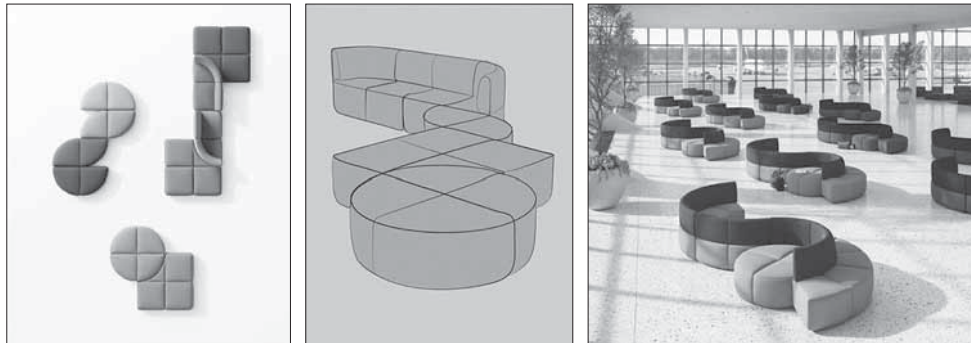

Figure 12

Figure 12 shows modular seating designed by Helen Kontouris.

- a. Identify the design field of which Figure 12 is an example. 1 mark

- b. With reference to Figure 12, describe **two** needs that might have been identified in the brief and that have influenced the form of the seating. 3 marks

- c. Discuss **two** ways in which the designer might have evaluated the seating during **one** stage of the design process. 3 marks

DO NOT WRITE IN THIS AREA

DO NOT WRITE IN THIS AREA

CONTINUES OVER PAGE

TURN OVER

Question 7 (15 marks)

- a. Figure 13 shows an isometric drawing of a button with two holes. The holes go all the way through the button.

Draw a third-angle orthogonal drawing of the button in the space provided below. The arrow A indicates the front view.

Your drawing must:

- maintain a scale of 1:1
- include **three** views
- use correct technical drawing conventions
- use correct line styles and conventions
- include labels and the required symbol.

8 marks

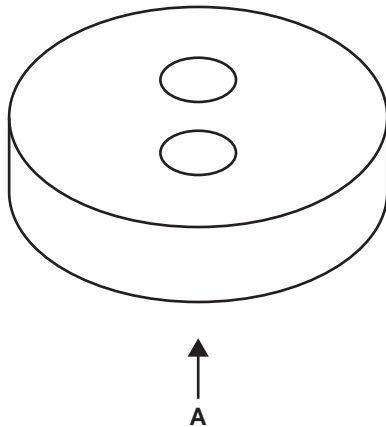
**Figure 13**

Complete your answer to **part a.** in the space below.

DO NOT WRITE IN THIS AREA

- b. Figure 14 shows an isometric drawing of a cardboard container for hot food.

Draw a packaging net of the container in the space provided below.

Your drawing must:

- maintain a scale of 1:1
- use correct line conventions
- include cut lines, fold lines and tabs.

7 marks

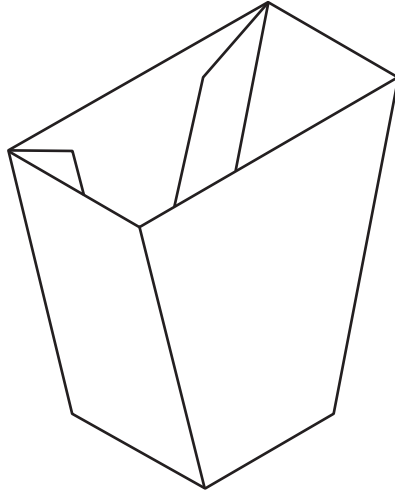

Figure 14

Complete your answer to **part b.** in the space below.

THIS PAGE IS BLANK

DO NOT WRITE IN THIS AREA

Question 8 (9 marks)

Figure 15 is a line drawing of painting equipment in a canvas holder.

Render the equipment and the holder to represent the surface textures indicated below. You may refer to the images on page 10 of the resource book.

Your response must:

- use the light source as indicated by the arrow to enhance the form
- include cast shadows
- use tone and colour to render the following materials:
 - canvas for the holder and ties
 - metal for the blade of the palette knife and for the band between the handle and bristles of the brush
 - wood for the handles of the palette knife and brush
 - bristles of the brush.

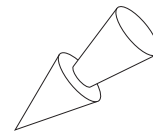
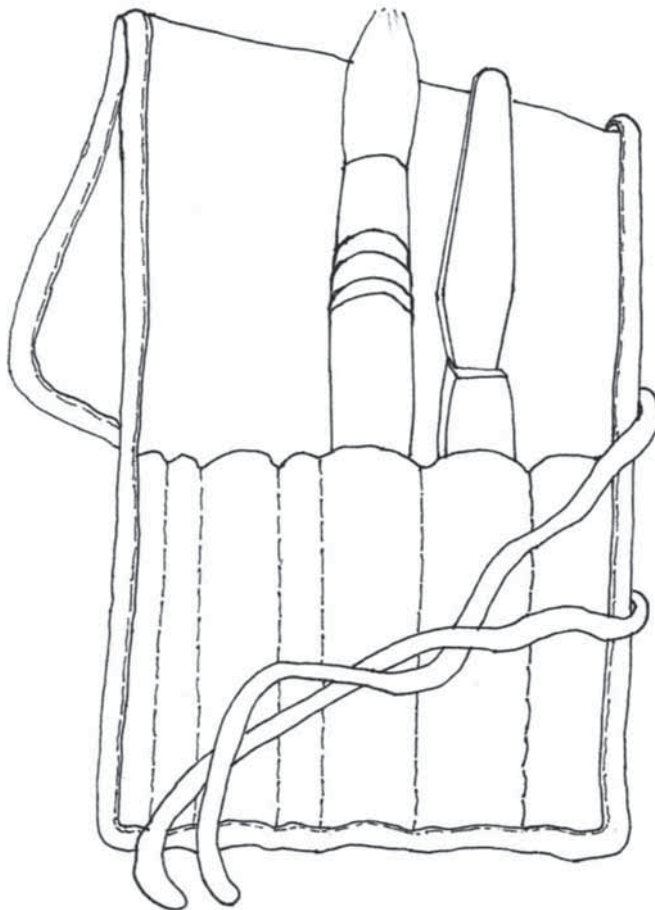

Figure 15

Question 9 (4 marks)

Refer to page 11 of the resource book for larger colour versions of the visual communications that are related to Question 9.



Figure 16

- a. The postage packs and carrier bag shown in Figure 16 are designed by The Better Packaging Co. They are reusable and fully biodegradable. They behave just like plastic bags except when placed in domestic compost, where they will biodegrade within months.

Identify **one** factor that might have influenced the design of the postage packs and describe how it might have influenced the design of these packs.

2 marks

DO NOT WRITE IN THIS AREA



Figure 17

- b. Figure 17 shows a logo used by the company that produces the postage packs from **part a**. It is a registered design.

Explain why this logo has been registered.

2 marks

DO NOT WRITE IN THIS AREA

Question 10 (4 marks)

Refer to page 12 of the resource book for larger colour versions of the visual communications that are related to Question 10.



Figure 18

Figure 18 shows the container for ice cream produced by Waratah Bay Ice Cream Co., which is located in a dairy region in rural Victoria.

- a. With reference to Figure 18, describe which design decisions the designer has made to relate the surface design of the container to the product and to where it is made. 2 marks

- b. Describe **two** techniques the designer has used to gain attention. 2 marks

DO NOT WRITE IN THIS AREA

Question 11 (21 marks)

A bedding company requires a fabric design for a children's bed set based on Australian wildlife. You are required to create a printed fabric design suitable for young children. The fabric designs will be used on a doona cover and pillowcase in the children's bed set.

Your design must:

- use a motif (image) based on **one** of the wildlife images on page 13 of the resource book
- emphasise shape
- use a coloured background
- effectively apply the design principle of contrast using colour.

- a. In the space provided below, generate a range of visualisation drawings using imagery based on the wildlife images on page 13 of the resource book.

3 marks

Complete your answer to **part a.** in the space below.

- b. Select **one** idea from the visualisation drawings that you have generated in **part a.** and develop a motif for the fabric design in the space provided below. This motif must be based on **one** of the wildlife images on page 13 of the resource book.

3 marks

Complete your answer to **part b.** in the space below.

- c. Use the motif from **part b.** multiple times to create the fabric design for the doona cover. In the template provided below, produce a presentation drawing of the doona cover.

Your design must:

- emphasise shape
- use a coloured background
- effectively apply the design principle of contrast using colour.

8 marks

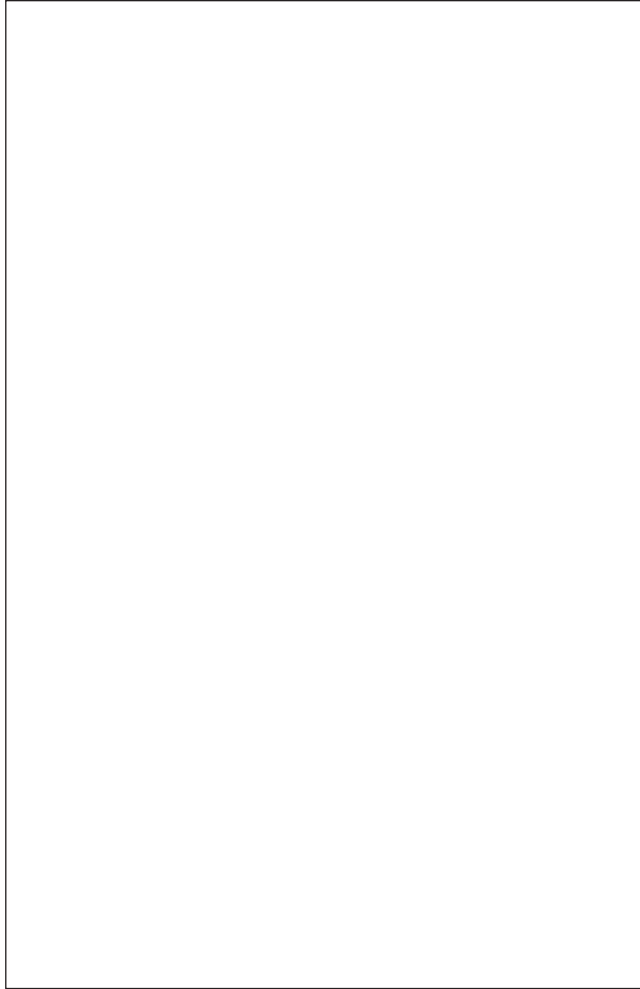

DO NOT WRITE IN THIS AREA

- d.** Based on the fabric design from **part c.**, create a fabric design for a pillowcase that complements that of the doona cover. Using the motif of your selected wildlife image, adapt your fabric design for the doona cover to create a fabric design for the pillowcase and produce a presentation drawing in the template provided below. Use annotations to explain the adaptations that you have made for the fabric design for the pillowcase.

Your design must:

- complement the design for the doona cover
- use a different scale
- adapt the colour.

7 marks

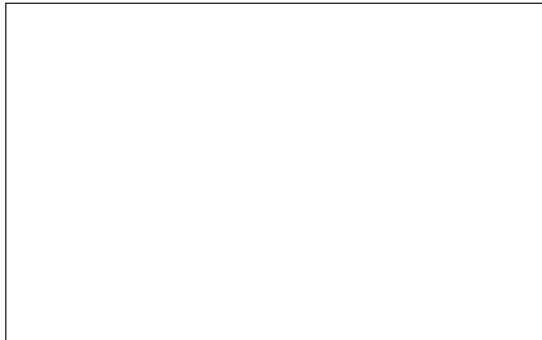

DO NOT WRITE IN THIS AREA

TURN OVER

Sources

Figure 2: b.box sippy cup design by Dannielle Lisa Michaels and Monique Miriam Filer; b.box sippy cup, <www.bbox.com.au/products/new-sippy-cup-apple> (by permission, © b.box for kids); Figure 4: 2019 Land of Plenty festival poster, <www.landofplentyfestival.com/history> (courtesy of Red Hill Entertainment); Figure 5: Artwork design by Marcus Lee Design for *Reconciliation Action Plan July 2019 – July 2021*, Reece Group, 2019, <<https://group.reece.com/assets/Reece-Reconciliation-Action-Plan.pdf>> (courtesy of Reece Australia and Marcus Lee Design); Figure 9: Shepparton Art Museum logo, <www.sheppartonartmuseum.com.au> (logo reproduced with permission of Shepparton Art Museum); Figures 10 & 11: Designs by Laura Blythman, <www.laurablythman.com.au/design-portfolio/project-five-nlleh> (by permission of Laura Blythman); Figure 12: Bauhaus seating system designed by Helen Kontouris, <www.lenfurniture.com/projects/bauhaus/> (courtesy of Helen Kontouris at Len Furniture); Figure 16: comPOST Packs designed by The Better Packaging Co., <www.betterpackaging.com/products/compost-packs> (courtesy of Better Packaging Co.); Figure 17: Australasian Bioplastics Association home compostable verification logo used by The Better Packaging Co., <<https://www.betterpackaging.com/pages/compostrange>> (courtesy of Australasian Bioplastics Association – Note that ABAP20036 is currently suspended)

**Victorian Certificate of Education
2021**

VISUAL COMMUNICATION DESIGN

Written examination

Monday 8 November 2021

Reading time: 9.00 am to 9.15 am (15 minutes)

Writing time: 9.15 am to 10.45 am (1 hour 30 minutes)

RESOURCE BOOK

Instructions

- A question and answer book is provided with this resource book.
- Refer to instructions on the front cover of the question and answer book.

Students are NOT permitted to bring mobile phones and/or any other unauthorised electronic devices into the examination room.

THIS PAGE IS BLANK

Reference material for Question 1

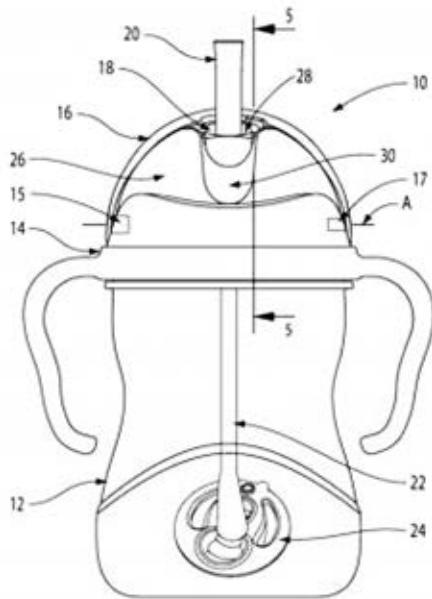

Figure 2

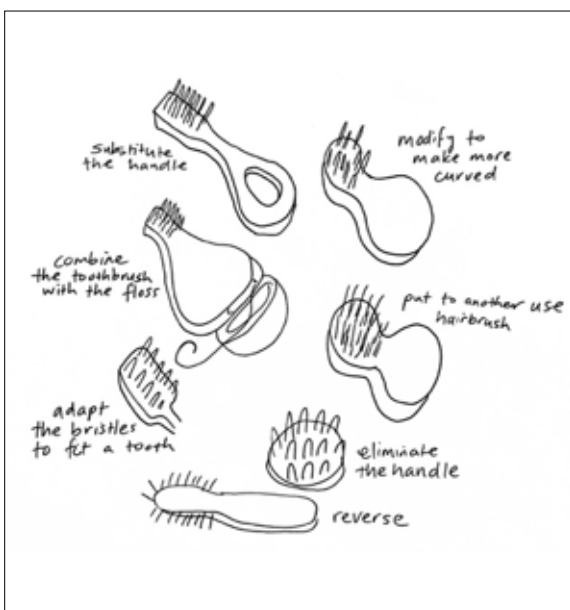

Figure 3



Figure 4

Reference material for Question 2



Figure 5

Reference material for Question 3



Figure 6



Figure 7

TURN OVER

Reference material for Question 3



Figure 8

Reference material for Question 4

sam.



Figure 9

Reference material for Question 5



Figure 10



Figure 11

Reference material for Question 6

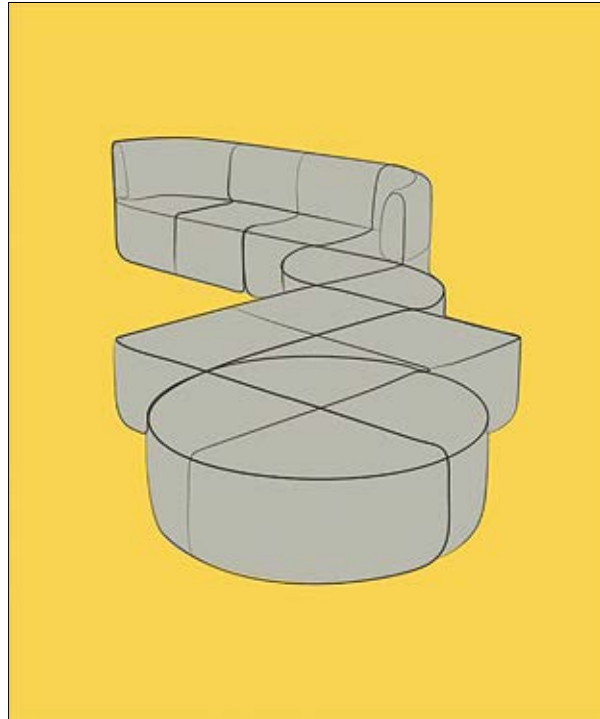
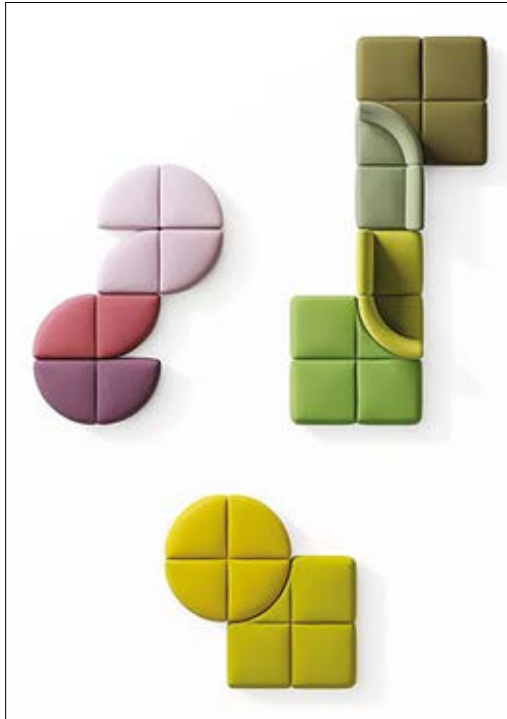
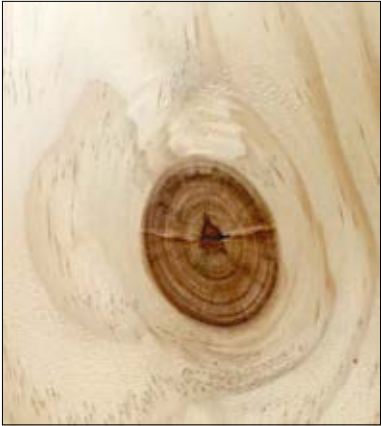

Figure 12

Reference material for Question 8



Reference material for Question 9



Figure 16



**Home Compostable
AS 5810
ABAP 20036**

Figure 17

Reference material for Question 10



Figure 18

Reference material for Question 11



Sources

Figure 2: b.box sippy cup design by Dannielle Lisa Michaels and Monique Miriam Filer; b.box sippy cup, <www.bbox.com.au/products/new-sippy-cup-apple> (by permission, © b.box for kids); Figure 4: 2019 Land of Plenty festival poster, <www.landofplentyfestival.com/history> (courtesy of Red Hill Entertainment); Figure 5: Artwork design by Marcus Lee Design for *Reconciliation Action Plan July 2019 – July 2021*, Reece Group, 2019, <<https://group.reece.com/assets/Reece-Reconciliation-Action-Plan.pdf>> (courtesy of Reece Australia and Marcus Lee Design); Figure 9: Shepparton Art Museum logo, <www.sheppartonartmuseum.com.au> (logo reproduced with permission of Shepparton Art Museum); Figures 10 & 11: Designs by Laura Blythman, <www.laurablythman.com.au/design-portfolio/project-five-nlleh> (by permission of Laura Blythman); Figure 12: Bauhaus seating system designed by Helen Kontouris, <www.lenfurniture.com/projects/bauhaus/> (courtesy of Helen Kontouris at Len Furniture); Figure 16: comPOST Packs designed by The Better Packaging Co., <www.betterpackaging.com/products/compost-packs> (courtesy of Better Packaging Co.); Figure 17: Australasian Bioplastics Association home compostable verification logo used by The Better Packaging Co., <<https://www.betterpackaging.com/pages/compostrange>> (courtesy of Australasian Bioplastics Association – Note that ABAP20036 is currently suspended)

Resources for Question 11

Clockwise from top left: rickyd/Shutterstock.com; Marco Tomasini/Shutterstock.com; Eric Isselee/Shutterstock.com; Independent birds/Shutterstock.com; Michal Pesata/Shutterstock.com; Jukka Jantunen/Shutterstock.com; David Dennis/Shutterstock.com; Wang LiQiang/Shutterstock.com